



Nikon

Confocal Microscope C1 <EZ-C1 Software>

Ver. 3.80

Spectral Imaging System C1si Version

Table of Contents

Table of Contents.....	1	3.5 Acquire Settings (2: Image acquiring mode settings).....	66
Preface	3	3.5.1 XY.....	66
Limitations and About the Viewer	4	3.5.2 Line Lambda.....	66
1 Getting Started with EZ-C1	6	3.5.3 Average	68
1.1 C1-si System Configuration	6	3.5.4 Frame Lambda	69
1.2 Switching Detectors	7	3.5.5 Z-stack.....	70
1.2.1 Switching Detectors	7	3.5.6 Time Series.....	72
1.2.2 Detector Function Differences.....	7	3.6 View settings.....	76
1.3 Parts.....	8	3.6.1 Info tab.....	76
1.4 Requirements.....	8	3.6.2 Color Tab	77
1.5 Installing.....	8	3.6.3 View Tab	87
1.5.1 Network Settings.....	8	3.6.4 View bar.....	98
1.5.2 Installing the software	10	3.6.5 Transmitted Tab	99
1.5.3 Setting up the EZ-C1 Dongle License.....	11	3.7 Laser Control	100
1.5.4 Setting the C1 Hardware.....	14	3.8 Laser Power Monitor.....	103
1.6 Uninstalling the EZ-C1	16	3.9 Objective Bar	103
1.7 Starting the EZ-C1.....	16	3.10 CLEM Bar	105
1.7.1 Selecting a Profile	17	4 Menu Functions	106
1.8 Exiting the EZ-C1.....	17	4.1 Files	106
1.8.1 Saving a Profile.....	17	4.1.1 Open	106
2 Basic Operations.....	19	4.1.2 Close	107
2.1 Basic Operations.....	19	4.1.3 Save	107
2.2 Structure of EZ-C1 (C1si-ready version).....	27	4.1.4 Save As	108
3 Common Tool Dialog Boxes.....	30	4.1.5 Save As Options	109
3.1 Laser and Detector (Laser and Detector Status Display).....	30	4.1.6 Print	113
3.2 Laser and Detector Profiles (Laser and Detector Settings)	34	4.1.7 Print Preview	113
3.2.1 Detector Tab.....	34	4.1.8 Print Setup.....	113
3.2.2 Frame Lambda Series	40	4.1.9 Description.....	113
3.2.3 Binning/ Skip Tab	45	4.1.10 Recent Files.....	114
3.2.4 Reference Tab.....	47	4.1.11 Exit.....	114
3.3 Gain Bar (Gain Setting).....	50	4.1.12 File Bar	115
3.3.1 Gain Tab	50	4.2 Configure	116
3.3.2 Offset Tab.....	52	4.2.1 Devices.....	116
3.4 Acquire Settings (1: Scan control).....	53	4.2.2 License	117
3.4.1 Acquire Settings dialog box	53	4.2.3 Objectives	117
3.4.2 Scan Control	54	4.2.4 Save Options	119
3.4.3 Image Acquisition Modes	56	4.2.5 Startup Profile	121
3.4.4 Scan Settings.....	57	4.2.6 Acquire Option	123
3.4.5 Line Scanning	58	4.3 Data	124
3.4.6 Scan Mode.....	58	4.3.1 Analyze.....	124
3.4.7 Displaying the Scan Range.....	60	4.3.2 Annotate/ Annotate bar	129
3.4.8 Navigation window	61	4.3.3 Calculate (Ratio).....	133
3.4.9 Bi-Directional Scan bar	64	4.3.4 Filter.....	134
3.4.10 Acquire bar	64	4.3.5 Reduce	136
3.4.11 Acquire Position bar.....	65	4.3.6 Spot	138
3.4.12 Acquire Mode bar.....	66	4.3.7 Volume.....	144
		4.3.8 Data bar.....	147
		4.4 Launcher.....	148
		4.5 Macro.....	149
		4.5.1 Channel Tiled / Untiled.....	149

4.5.2	Ids Tiff Convert (Ids Tiff Convert Macro)	149	6	Visual Basic for Applications Support Functions	228
4.5.3	Switch Scanning Area procedure	152	6.1	VBA menu	228
4.6	Spectral	154	6.1.1	Customize menu	228
4.6.1	Unmixing	154	6.1.2	Macro menu	234
4.6.2	Segmentation	159	6.1.3	Projects menu	236
4.7	Data Series	161	6.1.4	Visual Basic Editor	238
4.7.1	Data Series graph	161	6.1.5	Projects bar	238
4.7.2	Various Settings	163	6.2	Description of Macro-related Files	239
4.7.3	Cursor	167	6.2.1	Default project	239
4.7.4	Basic arithmetic operations on graph items	168	6.2.2	User project	239
4.7.5	Measurement functions	169	6.2.3	Settings files	239
4.7.6	Inserting Graphs	175	6.2.4	Method	240
4.7.7	Saving Graphs	177	A	Experiment Sequence Macro	241
4.7.8	Data Series/ Data Series Bar	178	A.1	FRAP Sequence Macro	243
4.8	Tools	180	A.2	FLIP Sequence Macro	256
4.8.1	Layout of the Tools dialog box	181	A.3	2 Excitation 1 Emission Ratio Sequence Macro	263
4.8.2	Status bar	183	A.4	Multipoint Time-lapse Macro	273
4.9	VBA	183	A.5	FRET Sequence Macro	282
4.10	Window	184	A.6	Colocalization Macro	293
4.10.1	Dark Room mode	184	A.7	AutoGain Macro	299
4.10.2	Freeze Window Layout, Next, New, Previous, Tile, Opened Window	184	A.8	Live Unmix Macro	302
4.10.3	Merge	186	A.9	Z-stack Intensity Control Macro	305
4.11	Help	188	A.10	Tiff Series Export Macro	311
5	Hardware-related Settings	189	A.11	SimpleGUI Macro	314
5.1	Nikon RFA Z-drive	189	A.12	Thumbnailer	316
5.1.1	Installing the RFA Z-drive	189	B	Data File Formats	318
5.1.2	The RFA tab	189	B.1	Image Cytometric Structure	318
5.1.3	Z-scan tab	190	B.2	Adobe Tagged Image File Format	318
5.2	Confocal C1 Settings	192	B.3	Audio Video Interleaved Format	318
5.2.1	Lasers tab	192	B.4	Windows Bitmap File Format	318
5.2.2	Power Monitor tab	196	B.5	Excel Worksheet	319
5.2.3	Pinhole tab	197	B.6	Ascii Text Format	319
5.2.4	Mirrors tab	198	C	Troubleshooting	320
5.2.5	Information tab	200			
5.2.6	Trigger tab	201			
5.2.7	Bleach tab	202			
5.2.8	Standard Detector tab	204			
5.2.9	Spectral Detector tab	207			
5.3	Microscope Ti	208			
5.3.1	Ti Tab	209			
5.3.2	Z-Scan Tab	210			
5.3.3	Stage Tab	211			
5.3.4	Perfect Focus System Bar	212			
5.3.5	Stage Tools Bar	213			
5.3.6	Ti Bar	213			
5.4	Microscope TE2000	214			
5.4.1	TE2000 tab	215			
5.4.2	Z-Scan tab	216			
5.4.3	TE2000 bar	217			
5.4.4	Perfect Focus System Bar	218			
5.5	Microscope i-Series (90i, 80i)	219			
5.5.1	90i tab, 80i tab	220			
5.5.2	Z-Scan tab	221			
5.5.3	Microscope Tools bar	223			
5.6	Prior ProScan	225			
5.6.1	Controller tab	225			
5.6.2	Stage tab	226			
5.6.3	Stage toolbar	227			

Preface

The EZ-C1 is the operation software for the Nikon Confocal Microscope C1 and C1-si.

The EZ-C1 can easily display not only simple 2D images, but also 3D and 4D images as well as 2D, 3D and 4D time series images. And it can be accomplished by pressing a button once or twice.

Chapter 1, "Getting Started with EZ-C1," describes the system configuration, how to switch between spectral and standard modes and installation procedures for a C1-si system.

Chapter 2, "Basic Operations" describes basic operations and provides an overview of screen elements.

Chapter 3, "Common Tool Dialog Boxes" describes major functions.

Chapter 4, "Menu Functions" provides a detailed overview of display and analysis functions.

Chapter 5, "Hardware-related Settings" describes the configuration and use of the supported devices.

Chapter 6, "Visual Basic for Applications Support Functions" describes the use of macros in EZ-C1.

"A Experiment Sequence Macro" describes the methods to create and execute the FRAP Sequence.

"B Data File Formats" provides information on the file formats supported by EZ-C1.

"C Troubleshooting" includes information for solving hardware and software problems.

No part of this manual may be reproduced without Nikon's permission.

The content of this manual is subject to change without notice.

Nikon has carefully prepared this manual. However, we make no expressed or implied warranty of any kind and assume no responsibility for such errors or omissions.

Be sure to read the instruction manuals for the microscope and PC you plan to use with the EZ-C1.

■ Required knowledge

This manual was prepared for users having entry-level knowledge of Windows. If you encounter terms or tasks you do not understand, refer to your Windows instruction manuals for more information.

■ Trademarks

Microsoft[®], Windows[®] and Windows NT[®] are either registered trademarks or trademarks of Microsoft Corporation in the United States or other countries.

Pentium is either a registered trademark or trademark of Intel Corporation.

Products and brand name are trademarks or registered trademarks of their respective companies.

The "TM" and ® marks are not used to identify registered trademarks and trademarks in these instructions.

Limitations and About the Viewer

■Limitations

EZ-C1 is subject to the following limitations, depending on system, connected dongles and analog output board (PC attachable board for control of laser output) settings.

	C1si system + spectral dongle	C1 system + standard dongle
Functions supported in spectral mode - Viewing and saving 5 or more channels of data - Data Series graph (spectral graph) - Unmixing function and Segment function	Enabled	Disabled

	Four-laser unit	Three-laser unit
Line sequential function - Acquire Settings dialog box - Line Channel observation mode - Line Lambda tab	Enabled	Disabled

For the three-laser unit (when the four-laser unit is connected, the analog output board is required.)

	With analog output board	Without analog output board
Laser light brightness control function - Laser Control Bar dialog box - "Laser Control" settings on the Laser tab in the Confocal C1 option in the Configure menu Bleach function - "Bleach" settings in the Variable Delay setup sequence of the Time Series option in the Acquire Settings dialog box - "Bleach" settings on the Spots Of Interest tab of the View Settings dialog box - Bleach tab of the Confocal C1 option in the Configure menu	Enabled	Disabled

■About the Viewer

The EZ-C1 Viewer software can be used to browse or process images acquired and saved by EZ-C1. Unlike EZ-C1, EZ-C1 Viewer can be used without the C1 set. Only the hardware dongle (copy protection device) is needed. However, EZ-C1 Viewer lacks the image acquisition and device control functions provided by EZ-C1.

Listed below are EZ-C1 menus not available in EZ-C1 Viewer:

- Under Configure
 - Confocal C1
 - Microscope Ti-E
 - Microscope TE2000-U/S
 - Microscope TE2000-E
 - Microscope E1000
 - Z-drive RFA

- Under Tools
 - Acquire Bar
 - Acquire Mode Bar
 - Acquire Position Bar
 - Acquire Settings
 - Bi-Directional Scan
 - Gain Bar
 - Laser and Detector
 - Laser Control Bar
 - Laser Power Monitor
 - Time Series Progress

1

Getting Started with EZ-C1

This chapter describes system configuration, how to switch between spectral mode and standard mode, and how to install and set up the software.

1.1 C1-si System Configuration

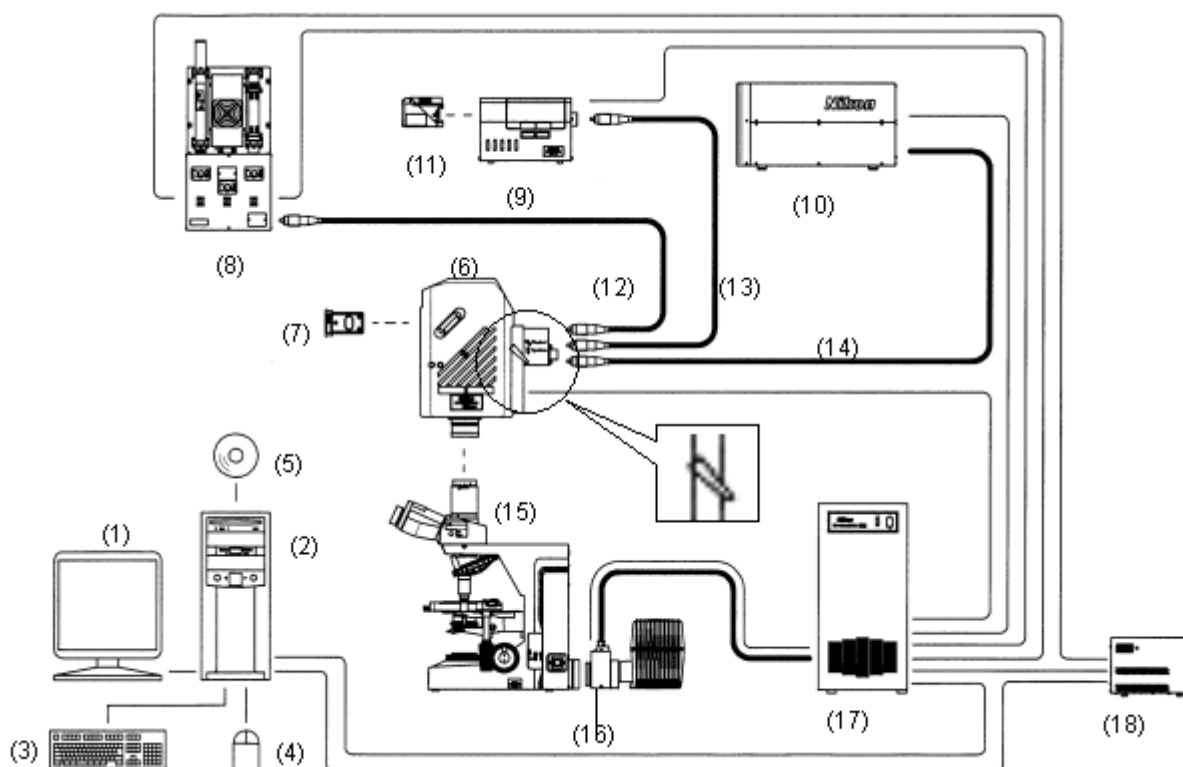

Name	
(1) Monitor	(10) Spectral detector unit
(2) PC	(11) Fluorescence filter
(3) Keyboard	(12) Fiber optic cable for excitation light
(4) Mouse	(13) Fiber optic cable for fluorescent light (for standard detector)
(5) Operation software	(14) Fiber optic cable for fluorescent light (for spectral detector)
(6) Scan head	(15) Microscope
(7) 1 st dichroic mirror	(16) Transmission detector (power connection provided only for motorized transmission detector)
(8) Laser unit	(17) Controller
(9) Standard detector unit	(18) AOM controller

CAUTION

- The detector switch on the scan head (6) switches between the standard detector (9) and spectral detector (10).

1.2 Switching Detectors

1.2.1 Switching Detectors

The scan head scans the laser beam (excitation light) transmitted from the laser through an optical fiber to illuminate the sample. It directs fluorescent emission from the sample to the detector. During observation the knob on the scan head allows you to select a standard detector with a filtering function or a spectral detector with a spectral function.

- Selecting the spectral detector invokes the Spectral mode in which EZ-C1 relies on spectroscopy to acquire images consisting of up to 32 channels.
- Selecting the standard detector invokes the Standard mode in which EZ-C1 uses filters to acquire images consisting of up to 4 channels.

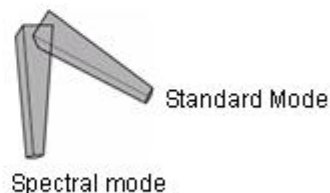

1.2.2 Detector Function Differences

		Spectral detector	Standard detector
Maximum image resolution		Firmware versions earlier than 4.0: 512 x 512 4.0 and later: 1024 x 1024	2048 x 2048
Number of simultaneously energizable lasers		Three-laser unit: max. three lasers Four-laser unit: max. seven lasers	
Available/unavailable functions	Acquire Settings dialog box - Bi-directional function - Channel Series function - Line Sequential function	Available	Unavailable

1.3 Parts

EZ-C1 (Spectral Imaging System C1si Version) is a software package of optional functions on EZ-C1.

The package is provided with the following:

- License card
- EZ-C1 instructions
- License card user's guide

Use the CD-ROM and other accessories supplied with EZ-C1.

1.4 Requirements

To run EZ-C1, we recommend a personal computer with the following specifications:

- OS: Microsoft Windows 2000 Professional with Service Pack 4 or later or Windows XP Professional with Service Pack 2 or later
- CPU: Pentium IV operating at 3.4GHz or higher with Hyper Threading technology
- RAM: 2 GB or more
- HDD: SATA II (SATA150), 7200rpm, 8MB Cache
At least 40MB of available disk space is required for installation.
Sufficient large and fast hard disk is required to save the images
Ex.) 4-ch image (512x512): 2MB, 32-ch image (512x512): 16MB
- Monitor: a monitor and video adapter for 1600 x 1200 (UXGA) pixels in true color mode (24-bits)

Note

- Some PCs might not work in this environment. If this happens, please consult Nikon or its local representatives.

1.5 Installing

The EZ-C1 software comes on a CD-ROM disk. Install the EZ-C1 software on your computer following the instructions below. You may skip over this item if C1 hardware setup, installation of the application, and all settings are complete.

1.5.1 Network Settings

In order to use the C1 hardware, it is necessary to change your PC's network settings. Please change the settings according to the following example. The description of the following procedure assumes that there are two network cards installed in the PC and that one of them is directly connected to the C1 controller with a cross cable.

- (1) Log in as the administrator.

Network settings cannot be changed unless you log in as the administrator.

- (2) Right click on the icon “My Network” on the desktop, and select “Properties” from the popup menu.

A “Network and Dial-up Connections” dialog box (Figure 1.5-1) will appear.

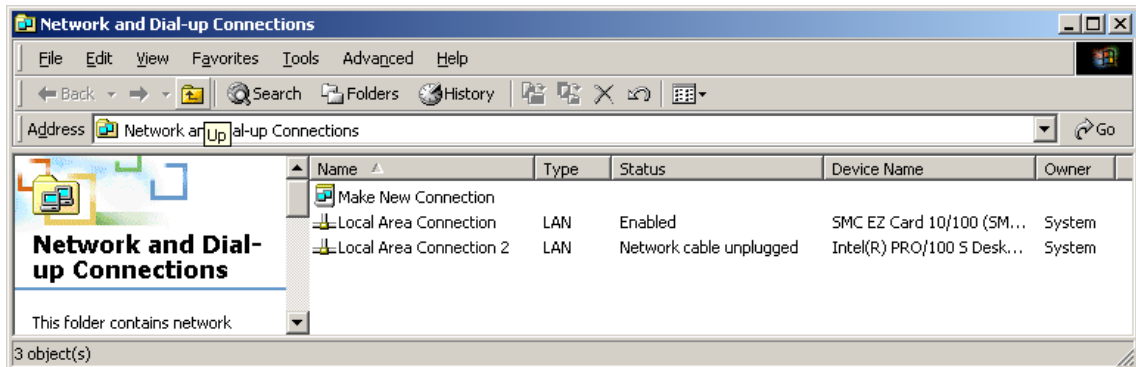

Figure 1.5-1 Network and Dial-up Connections dialog box

- (3) Confirm that the network card used to connect to the C1 controller appears in the name field in the Network and Dial-up Connections dialog box (Figure 1.5-1). After confirming that the network card is registered, right click on its name. Select “Properties” from the popup menu.

The “Local Area Connection 2 Properties” dialog box (Figure 1.5-2) will appear.

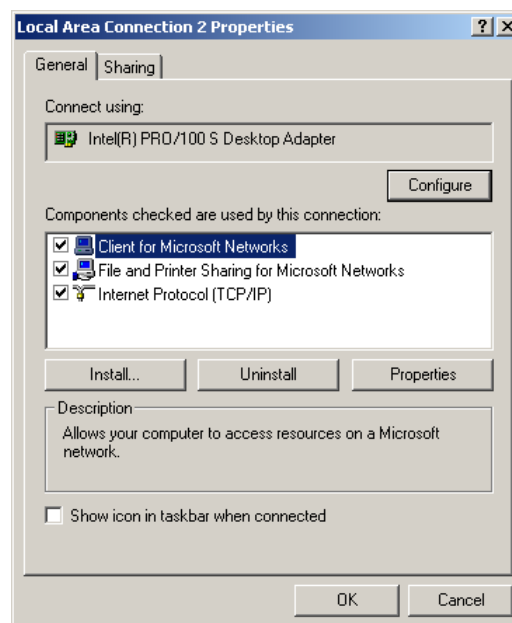

Figure 1.5-2 Local Area Connection 2 Properties dialog box

- (4) Select “Internet Protocol TCP/IP” on the “Local Area Connection 2 Properties” dialog box (Figure 1.5-2). Then, select “Properties.”

The “Internet Protocol (TCP/IP) Properties” dialog box (Figure 1.5-3) will appear.

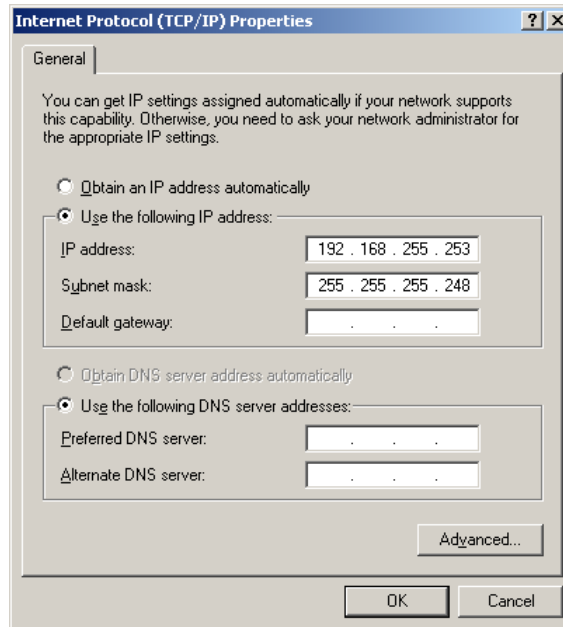

Figure 1.5-3 Internet Protocol (TCP/IP) Properties dialog box

- (5) Set the IP address and subnet mask just as shown on the “Internet Protocol (TCP/IP) Properties” dialog box (Figure 1.5-3).

IP address	•••192.168.255.253
Subnet mask	•••255.255.255.248

1.5.2 Installing the software

Log in as the administrator and load the EZ-C1 CD-ROM into the CD-ROM drive of the PC. The installer will start automatically.

- (1) First, click on “Install Hardware Protection Driver” and install the driver for the dongle.

Note

- If the selectable menu is not displayed, select “My Computer” - “Tools” - “Folder Options” - “View,” uncheck “Hide file extensions for known file type.”

- (2) Next, click “Install EZ-C1.”

- (3) A screen similar to the one shown below (Figure 1.5-4) will appear. Press the upper button in this screen to install EZ-C1 or the lower button to install only Viewer.

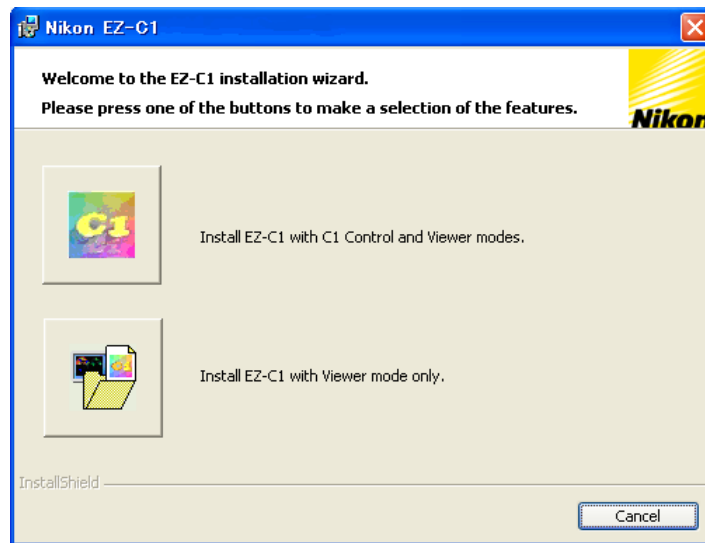

Figure 1.5-4 Installer screen

- (4) Perform the steps indicated by the respective installer's installation wizard.

Note

- If the installer does not launch automatically, launch the setup.exe program found on the EZ-C1 CD-ROM.
- If you purchased the AOM unit, you need to install the driver for NI-DAQ cards (one that is inserted into the PC to control the laser power) separately from EZ-C1.

1.5.3 Setting up the EZ-C1 Dongle License

To run the EZ-C1 program, the EZ-C1 dongle must be plugged on a USB port of the PC.

When using the EZ-C1si and the EZ-C1 Viewer si for the first time, follow the steps below to set up the dongle license. These instructions can be skipped if the dongle is already set up.

1.5.3.1 Installing the License Setup Software

- (1) Log in as the Administrator and insert the EZ-C1 CD-ROM in the CD drive of the PC. The installer starts up automatically.
- (2) Click the "EZ-C1 license option utility."
- (3) Follow the instructions given by each installer wizard after the installer starts up.

Note

- If the installer does not start up automatically, click the setup.exe program on the EZ-C1 CD-ROM to start it.

1.5.3.2 Checking the validity of the EZ-C1 and the EZ-C1 Viewer si license

First, insert the HASP key in the USB port of the computer. Then, start up the “EZ-C1 license option utility.” To start the “EZ-C1 license option utility,” select “Program” → “Nikon” → “EZ-C1 3.80” → “EZ-C1 license option utility” menu entry from the Windows [Start] button. The window shown below appears.

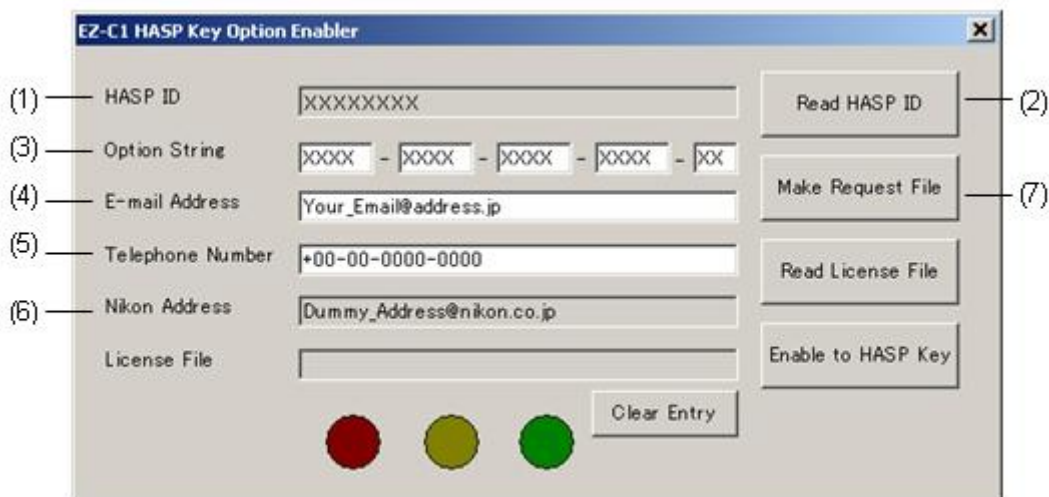

- (1) HASP ID: The HASP ID appears automatically.
- (2) [Read HASP ID]: If the HASP ID is not read in Step (1) above, press this key after pressing the HASP key to read the HASP ID again.
- (3) Option String: Enter the 18-digit character string on the license card.
- (4) E-mail Address: Enter your E-mail address.
- (5) Telephone Number: Enter your phone number.
- (6) Nikon Address: The Nikon E-mail address attached to the license request file
- (7) [Make Request File]: Press this button to open the “Save File” dialog to create a license request file in the selected folder.

Send the license request file created in the selected folder to the E-mail address in Step (6). (For information on how to attach files to mail messages, refer to the user’s guide of your E-mail software.)

When Nikon has processed the file, an E-mail with an attached license file is returned. (For information on where attachment files are stored, refer to user’s guide of your E-mail software.)

Start up the “EZ-C1 license option utility” again.

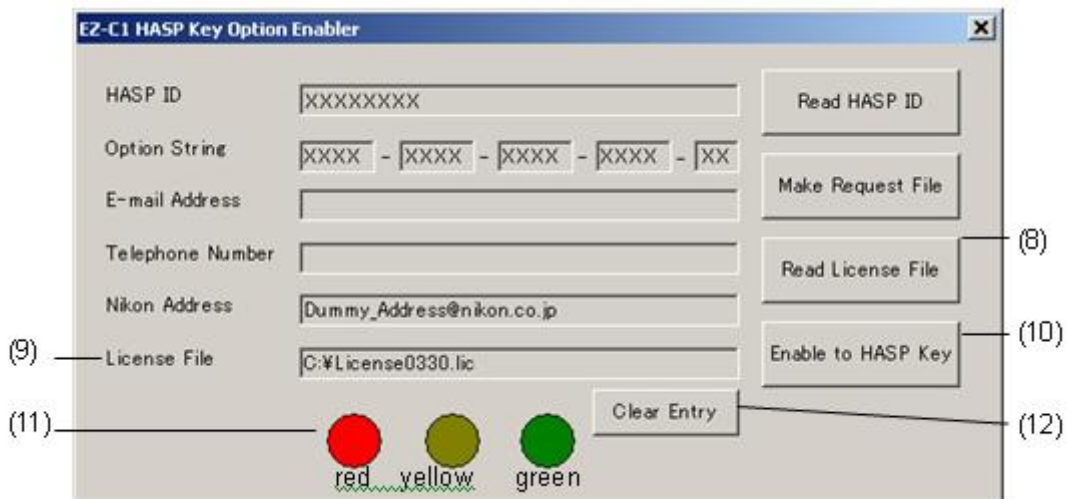

- (8) [Read License File]: Press this button to open the “Save File” dialog. Then select the license file attached to the E-mail message from the folder storing attached files.
- (9) License File: Open the selected license file.
- (10) [Enable to HASP Key]: Press this button to enable the HASP key option.
- (11) Status Indicators: The red, yellow and green indicators (from left to right) indicate HASP key status. The red indicator on the left is on when the option has not been enabled. The yellow indicator in the center is on when the HASP key is enabled. The green indicator on the right is on when validity expires and HASP key data has been updated.
- (12) [Clear Entry]: Clears all entered data. Use when the settings have to be changed, etc.

These are all the procedures required to enable the HASP key. Starting up EZ-C1 Ver. 3.80 after enabling the HASP key will add si functionality to EZ-C1.

1.5.3.3 Uninstalling License Setup Software

Select “Settings” → “Control Panel” → “Add/Remove Programs” utility from the [Start] button to remove the “EZ-C1 license option utility” from the hard disk. Select the “EZ-C1 license option utility” entry in the “Add/Remove Programs” utility and press the [Change/Remove] button.

1.5.4 Setting the C1 Hardware

Referring to Chapter 5, “Hardware-related Settings,” make the following settings for the items listed below.

1.5.4.1 Setting the laser type

Select “Confocal C1” on the EZ-C1 “Configure” menu to display the “Configure Confocal C1” dialog box. Set the wavelength corresponding to each of the lasers on the “Lasers” tab (Figure 1.5-5) of this dialog box (see 5.2.1).

For the three-laser unit system

Trigger	Bleach	Standard Detector	Spectral Detector
Lasers	Power Monitor	Pinhole	Mirrors
Lasers		Information	
<input checked="" type="checkbox"/> 1:	Wavelength	Shutter	Laser Control
<input checked="" type="checkbox"/> 2:	632.8 nm	closed	3 setup ...
<input checked="" type="checkbox"/> 3:	488.0 nm	closed	1 setup ...
	543.5 nm	closed	2 setup ...

For the four-laser unit system

Trigger	Bleach	Standard Detector	Spectral Detector
Lasers	Power Monitor	Pinhole	Mirrors
Lasers		Information	
<input checked="" type="checkbox"/> 1:	Wavelength	Shutter	Laser Control
<input checked="" type="checkbox"/> 2:	637.0 nm	closed	8 setup ...
<input checked="" type="checkbox"/> 3-1:	408.0 nm	closed	1 setup ...
<input checked="" type="checkbox"/> 3-2:	457.9 nm	closed	2 setup ...
<input checked="" type="checkbox"/> 3-3:	476.5 nm	closed	3 setup ...
<input checked="" type="checkbox"/> 3-4:	488.0 nm	closed	4 setup ...
<input checked="" type="checkbox"/> 4:	514.5 nm	closed	5 setup ...
	543.0 nm	closed	6 setup ...

Figure 1.5-5 Lasers tab of the Configure Confocal C1 dialog box

1.5.4.2 Check the pinhole break delay

Set the pinhole on the “Pinhole” tab of the “Configure Confocal C1” dialog box.

Select the size of the pinhole in the “Selection” field shown in Figure 1.5-6 and check the pinhole stops in the correct location with a catching sound.

Trigger	Standard Detector	Spectral Detector
Lasers	Power Monitor	Pinhole
Pinhole		Information
Selection		
<input type="radio"/> Use this fixed pinhole: 30 um small		
<input checked="" type="radio"/> Use the optimal pinhole		
Break Delay		
Mode: initial setting		
Clockwise: 40 ms		
Counter Clockwise: 60 ms		

Figure 1.5-6 Pinhole tab

1.5.4.3 Check the controller's IP address

Check the controller's IP address on the "Information" tab of the "Configure Confocal C1" dialog box. The IP address set initially at startup will appear, not necessarily the one shown in Figure 1.5-7. Check whether or not the IP address shown is as follows, and if it is different, correct it.

IP address = 192.168.255.254

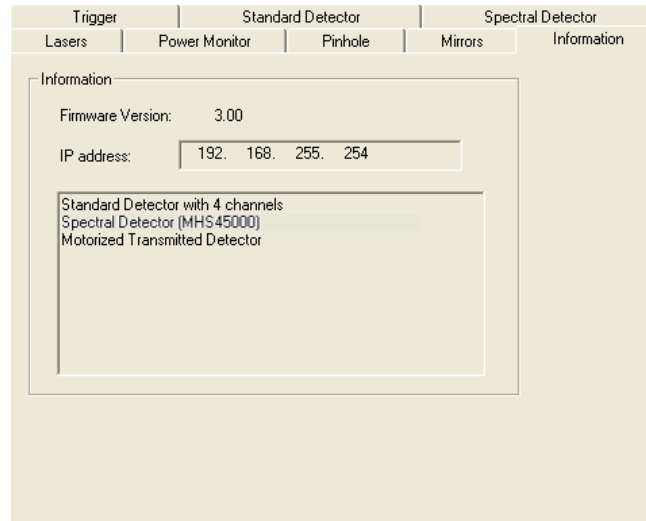

Figure 1.5-7 Information tab

1.5.4.4 Setting the channels

Set the number of channels to be used in the Channels in the Image field on the Standard Detector tab (Figure 1.5-8) on the Configure Confocal C1 dialog box.

Note

- Select "Trans" in Channels when the transmission detector is selected to acquire transmission detector data to EZ-C1.

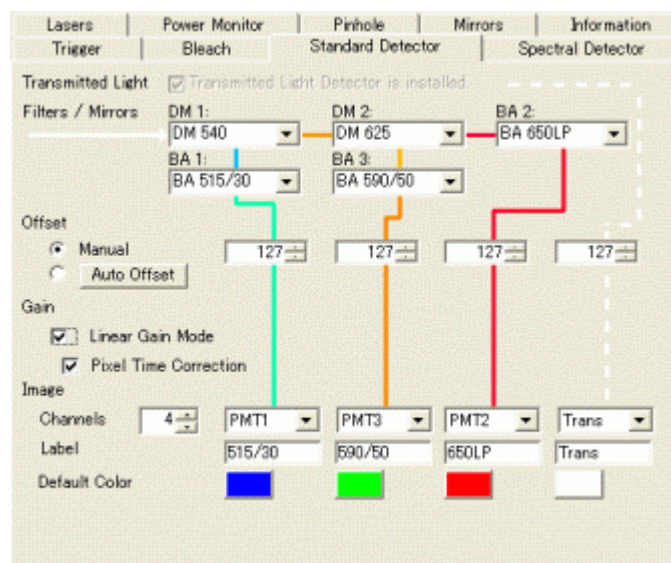

Figure 1.5-8 Standard Detector tab

1.6 Uninstalling the EZ-C1

It is possible to remove the EZ-C1 software from the hard disk using the “Add/Remove Programs” utility found on the “Control Panel” under “Settings” on the “Start” menu. To remove, use the “Add/Remove Programs” utility to select the EZ-C1 entry, and press the [Change/Remove] button.

1.7 Starting the EZ-C1

CAUTION

- Turn on the C1 controller before starting up EZ-C1.

To start the EZ-C1 program, select the Windows “Start” – “Programs” – “Nikon” – “EZ-C1 3.80” – “EZ-C1” menu entry (or the “EZ-C1 Viewer” menu entry to start Viewer) or double click the “EZ-C1 3.80” (or “EZ-C1 3.80 Viewer” to start Viewer) shortcut on the desktop.

If the program does not start correctly, refer to the “C Troubleshooting” to solve the problems.

- When macros are installed at the first start-up of the EZ-C1 immediately after installation, a dialog box prompting for your confirmation to load the macros appears. The macros selected here are automatically loaded at the following start-up.

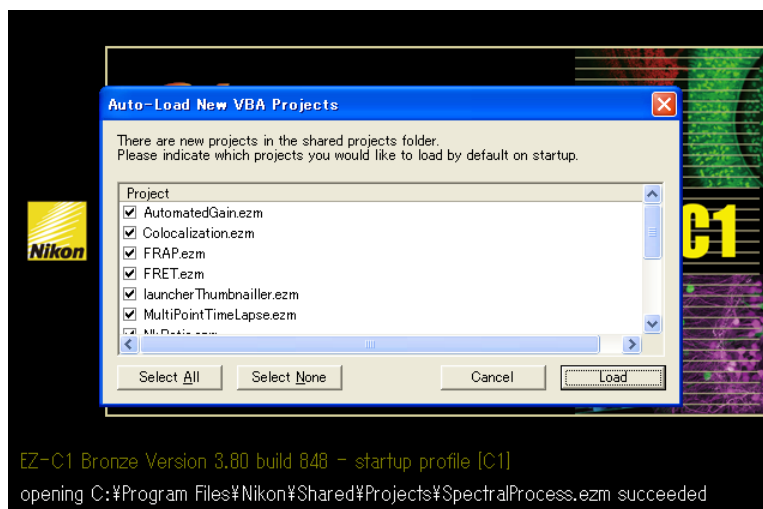

- When the EZ-C1 starts, the profile selection dialog box appears. If the EZ-C1 has just been installed and “C1.ezi” alone appears, select “C1.ezi.” (See 1.7.1.)
- Not all control dialogs may be visible after starting EZ-C1. The Tools menu lists the full range of available toolbar (see 4.8). To hide or show one of the tool windows, select the corresponding entry from the Tools menu.
- Best display results for images are obtained by setting the image color to “True Color.” To optimize the colors of an image, open the “Image property” found on the “Control panel,” select the “Settings” tab, and select “True Color” for the item “Image color.”

Note

- Log in as the Administrator or Power User. Device settings cannot be performed and EZ-C1 may not operate stably if you log in with other rights.

1.7.1 Selecting a Profile

When the EZ-C1 starts, the Profile selection dialog box appears.

By selecting a profile, you can reuse previously saved settings and apply or modify them to launch the EZ-C1 in the desired configuration.

Profile: The Profile function allows you to save and reuse ini file settings. The ini file primarily contains hardware configuration settings and screen layout. (For details, see Section 4.2.5, “Startup Profile.”)

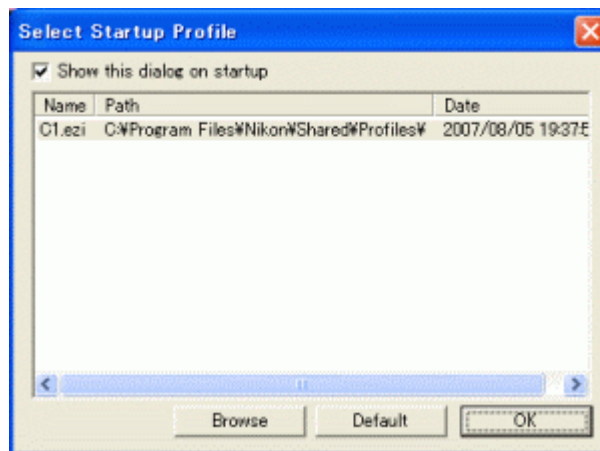

1.8 Exiting the EZ-C1

To exit the EZ-C1, quit the EZ-C1 application with the “Exit” on the “File” menu.

CAUTION

- Exit EZ-C1 before turning off the C1 controller.

1.8.1 Saving a Profile

When the EZ-C1 exits, it displays a dialog box prompting for your confirmation to save a profile.

Once a profile is saved, the settings in the profile can be reused the next time you start the EZ-C1. Settings can be saved separately for each user, each experiment, or any other classification. Determine how to save the ini file settings in the ezi file.

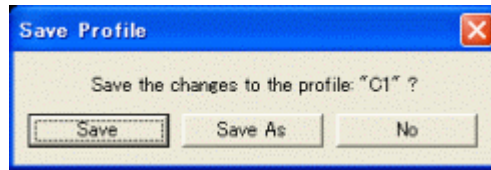

- Save: Saves the settings by overwriting the currently selected profile
- Save As: Saves the settings as a profile with a different name from the currently selected profile.
- No: Does not save the profile.

2

Basic Operations

Chapter 2, “Basic Operations” provides information on functions from acquiring spectral data to unmixing.

2.1 Basic Operations

EZ-C1 of the C1si ready version is used as follows.

1. Hardware Setup

1. Select the mode.

Select the Spectral Mode on the scan head.

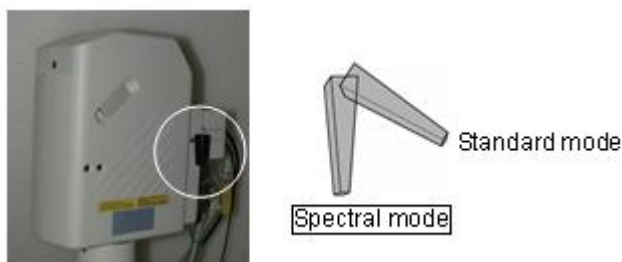

2. Check laser settings. (Perform these settings only at setup. Skip these instructions once the system has been set up.)

See. 5.2.1

Point to the Configure menu of the EZ-C1. Select the Laser tab in the Configure Confocal C1 dialog box. And check the lasers to be used.

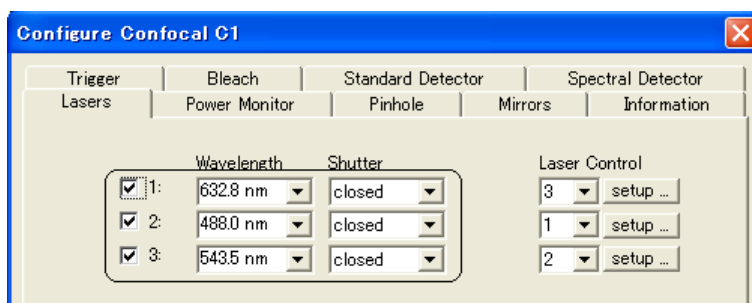

Important

- For the three-laser unit system, the Wavelength setting on the Laser tab must be set to suit the selected filter (488 or 514 nm) when the multi-Argon laser is used. Setting a wavelength that differs from that of the selected laser wavelength may damage the spectral detector.

3. Set up the spectral detector.

Press the [Edit] button in the Laser and Detector dialog box to open the Laser and Detector Profiles dialog box.

See. 3.1



Set the spectral detector and laser to be used in the Laser and Detector Profiles dialog box.

See. 3.2

- (1) Set up the laser to be used. (Select the wavelength. It becomes white.)
- (2) Set the resolution.
- (3) Set the wavelength range to be acquired.

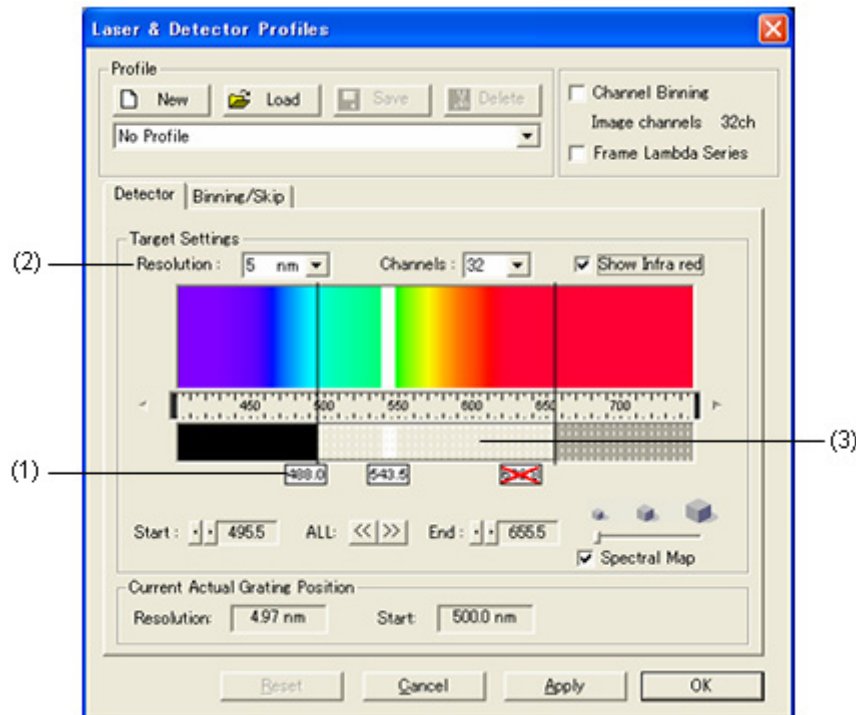

Press the [OK] button to take effect the settings and close the dialog box.

2. Image Acquisition

* First, focus on the specimen with a visual observation.

4. Specify the image acquisition settings.

Set the Steps value (resolution of the image) and other settings in the Acquire Settings dialog box.

See. 3.4

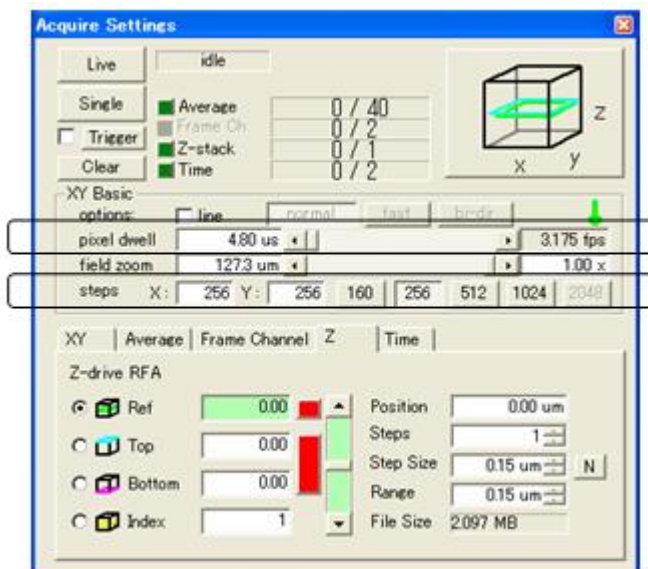

CAUTION

- Use a pixel dwell (scan speed) setting of between 4 to 30 μ s for the spectral mode.
- Select a capture resolution between 160 x 16 to 1024 x 1024 pixels.

See. 3.4.4

5. Specify the color mode of the image display.

Set the color mode in the Color mode on the Color tab in the View Settings dialog box. Select "Multi Channel True Color" to display images at a color setting that presents actual fluorescent emissions.

Select "Multi Channel Pseudo Color" to display images at a pseudo color setting.

See. 3.6

- Multi Channel True Color mode

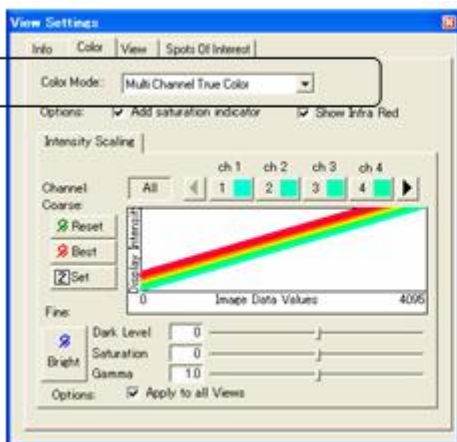

- Multi Channel Pseudo Color mode

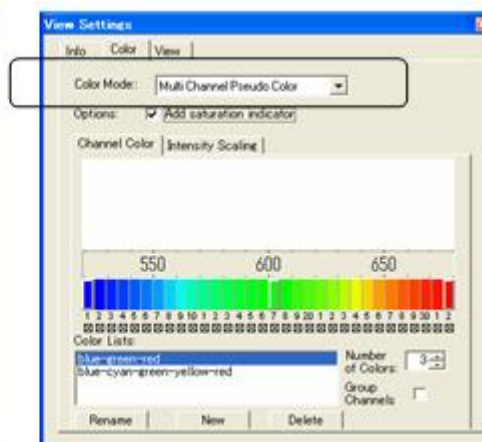

6. Adjust PMT gain.

Press the [Live] button in the Acquire Settings dialog box to start scanning. Adjust the gain on the Gain Bar dialog box while viewing the image in the C1 Spectral Live window. Press the [Live] button again after adjusting to stop scanning.

See. 3.3

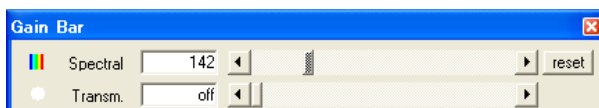
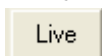
**CAUTION**

- Check Add saturation indicator on the Color tab in the View Settings dialog box and adjust the gain to prevent saturation of an image from occurring during scanning.

Options: Add saturation indicator

- Specify 700 V or under to acquire spectral data. Values are indicated in 255 steps. 700 V is indicated as "198." Therefore, specify the "198" or less value.
- When the [Live] button is pressed, laser light reflected from the specimen and the cover glass may be acquired in addition to the fluorescent emission. This is not due to a malfunction. For information on how to remove reflected light from fluorescent emission, refer to the Note in "4. Unmixing."

7. Adjust the Intensity Scaling for displaying images.

Adjust the Intensity Scaling on the Color tab in the View Settings dialog box. Press the [Bright] button while acquiring data with the spectral detector to set a range of brightness to which colors will be assigned. Press this button whenever needed.

See. 3.3

**8. Acquire the image.**

Set the observation mode in the Acquire Settings tool dialog box. Such as (2D (XY)/ 3D (XY-Zstack, XY-Time series)/ 4D (XY-Zstack-Time series)/ Average, etc.

See. 3.6.2

Press the [Single] button in the Acquire Settings dialog box to acquire image data.

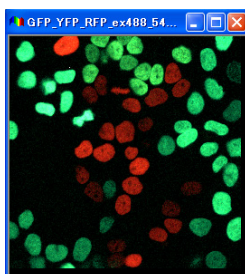



After acquiring the data, press the [Bright] button again to automatically adjust the Intensity Scaling.

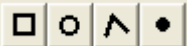

3. Checking Spectral Data

9. Display an averaged spectral graph for a spot.

Use the  buttons in the Annotate Bar tool dialog box to set a spot in an acquired image. Press the  button in the Annotate Bar tool dialog box to open the Data Series graph window.



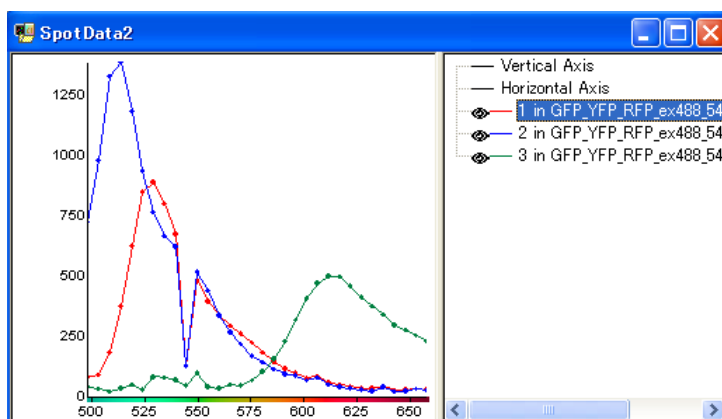

Adjust the location of the spot while observing the averaged spectral graph of the spot.



See. 4.3.2

10. Compare and save graphs in the Data Series graph window.

Use the  buttons in the Data Series Bar tool dialog box.

-  Use this button to place the cursor at the peak of each graph.
-  Use this button to display a saved graph or reference graph to enable comparison.
-  Use this button to standardize graph scale.
-  Use this button to save graph data in the text format.
- To view a spline approximation of a graph, right click the graph name to open the Properties dialog box, and check the Smooth check box.

See. 4.7.8

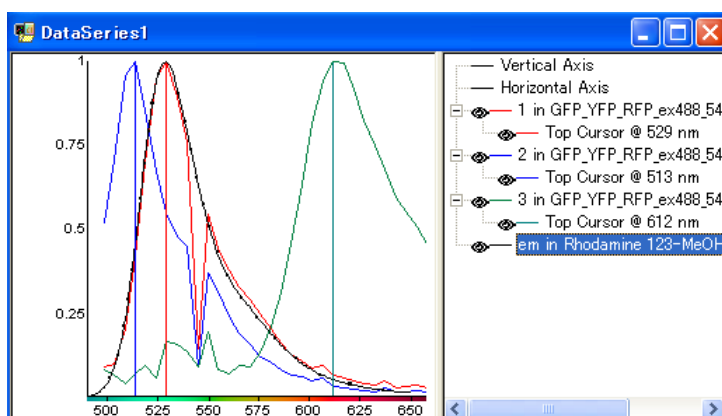

4. Unmixing

Important

- Spectral data for a reagent used in an unmixing process should as far as possible be acquired at the same wavelength range and resolution as target image data.
- Even if the same stain reagent is used, acquire new stain data for the specific cell when an experiment is performed on a different cell. The spectral data may vary slightly between different tissue and cell types.
- The data may not be processed correctly unless a suitable transmission setting is made in the Configure | Confocal C1 | Spectral Detector tab.

11. Acquire the image data necessary for unmixing.

a) When individual stain data can be identified by Spot on a multistained sample:

Then the unmixing process can be performed using the multistained sample data.

Required data • Multistained sample data A, B

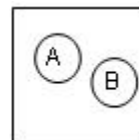

b) When individual stain data cannot be identified by Spot on a multistained sample:

First, acquire data for individual stained samples to enable accurate unmixing.

Required data

- Stained sample data A for A only
- Stained sample data B for B only
- Multistained sample data A, B

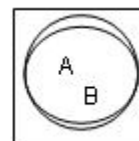

Note: When the sample is darkly stained or when an observation is performed near the cover glass surface, the reflection from the sample or cover glass may be acquired together with the fluorescent emissions. To handle this problem, scan the glass slide and the cover glass only to acquire the data of the reflection.

Added data: data of the reflection acquired only with the glass slide and cover glass
(Follow the instructions below when two lasers are used.)

Use the following procedure to acquire the reflection of each laser when two lasers are used.

a. In the Laser and Detector Profiles dialog box, select only the short wavelength laser, to acquire reflection data only for the short wavelength laser.

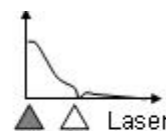

b. In the Laser and Detector Profiles, turn on both the short and long wavelength lasers, and adjust the laser unit ND to raise the peak of reflected beam data for the long wavelength laser.

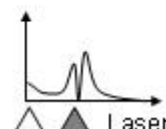

* Do not change any settings other than the laser shutter in the Laser and Detector Profiles dialog box.

12. Determine the spectral data to be used in the unmixing process.

Use the Spectral | Unmixing function to select the data to be used for unmixing.

Case of (a)

Use Spot to identify individual stain data in the multistained sample image.

Use the Data Series graph window to check the spectrum (and save it if necessary).

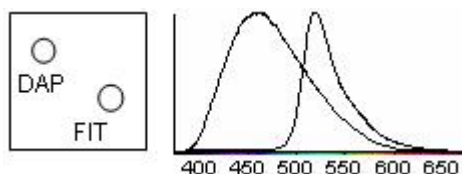
**Case of (b)**

Prepare stain data for each individual stained sample image.

Use the Data Series graph window to check the spectrum and save it if necessary.

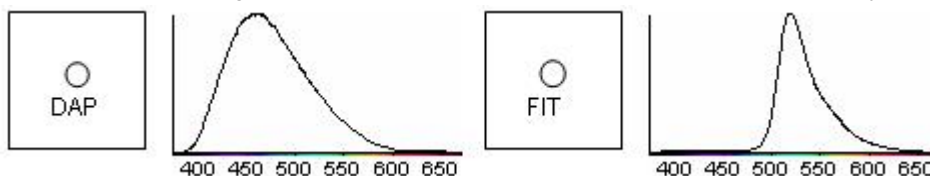
**13. Select the spectral data to be used in the unmixing process.**

Open the Unmix Spectral Image dialog box from the Spectral | Unmixing function and select the calculation elements. Also select the color for displaying the calculation result.

Case of (a)

Choose this option if you are unmixing from spectra derived from spots in the image.

(1) Select the spot to be calculated from the Spot data (Current Spot list) for the target image.

Use the  button to select Spot data at the cursor position as a calculation element.

(2) Select the color for displaying the calculation result.

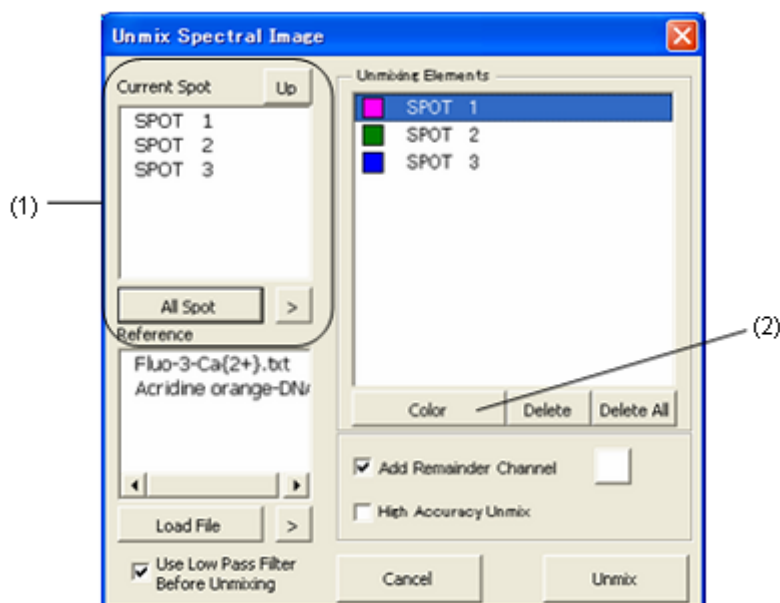

See. 4.6.1

See. 4.6.1

Case of (b)

Choose this option if you are unmixing from reference spectra.

See. 4.6.1

(1) Select calculation elements from saved spectral data (Reference list). Use the

Load File button if they do not appear in the list.

(2) Select the color for displaying the calculation result.

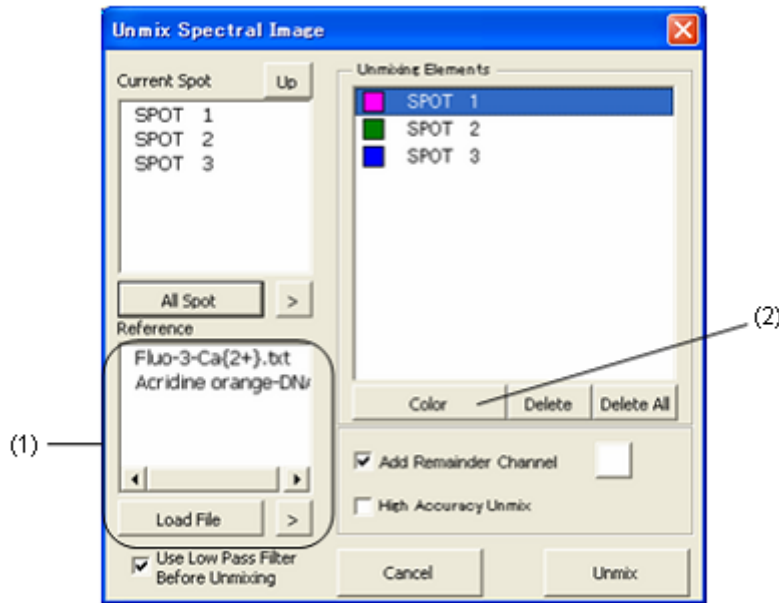

14. Perform the unmixing process.

Press the [Unmix] button in the Unmix Spectral Image dialog box to perform the unmixing calculation.

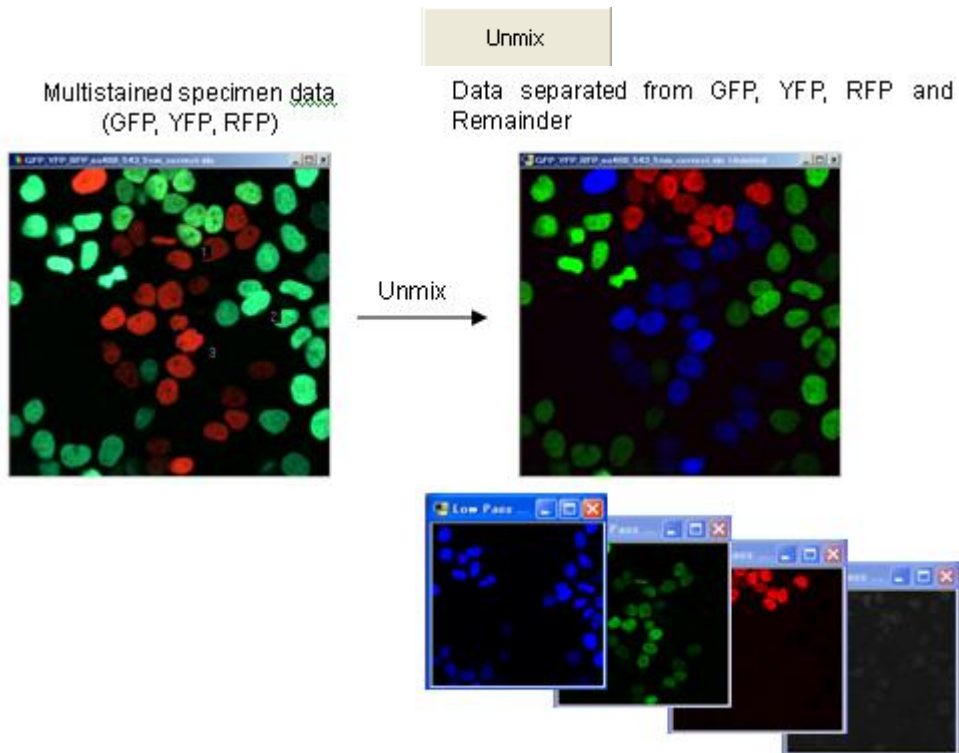

2.2 Structure of EZ-C1 (C1si-ready version)

The menu and tool dialog boxes of the EZ-C1 are shown below:

(1) - (11)

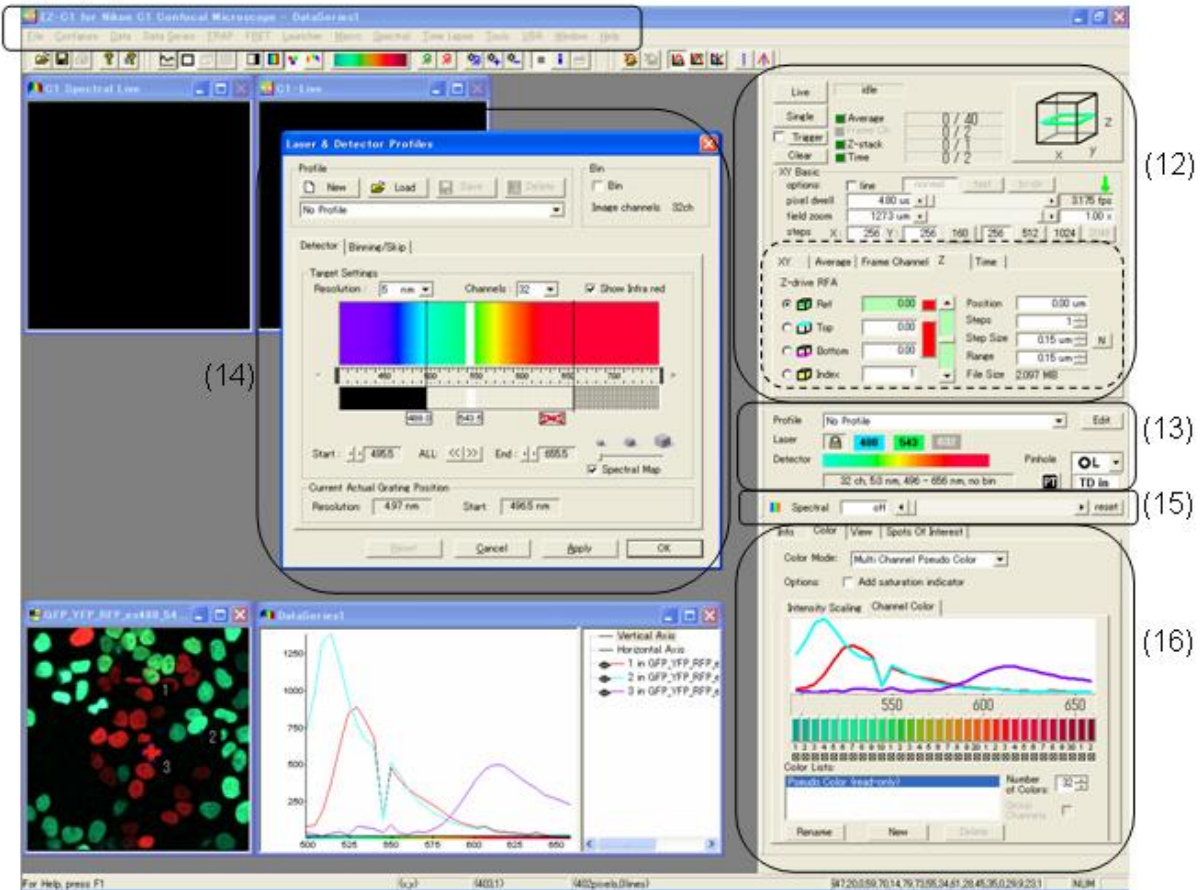

Menu functions:

(1) File (2) Configure (3) Data ((4) Data Series) (5) Launcher (6) Macro (7) Spectral (8) Tools (9) VBA (10) Window (11) Help

Tool dialog box functions:

(12) Acquire Settings tool dialog box
 (13) Laser and Detector tool dialog box
 (14) Laser and Detector Profiles tool dialog box
 (15) Gain Bar tool dialog box
 (16) View Settings tool dialog box

The menu structure and primary functions are shown below.

	Name	Function Overview
(1)	File (File related)	Open or save an image file. (See 4.1.)
(2)	Configure (Device settings)	Software setup should be based on the hardware configuration (e.g., device or laser setup). (See 4.2.)
(3)	Data (Image processing)	Process and analyze images (e.g., filter processing and histogram). (See 4.3.)
(4)	Data Series (Spectral graph operation)	Perform operations such as viewing and saving graph data in the Data Series graph window Data Series. (See 4.7.) ! This menu appears only when the Data Series graph window is active.
(5)	Launcher	Register and start other software. This function allows you handle images acquired by C1 using the registered software. (See 4.4.)
(6)	Macro	Use the default macro function. (See 4.5.)
(7)	Spectral (Spectral data analysis)	Analyze spectral data. (Unmixing process) (See 4.6.)
(8)	Tools (Tool dialog box)	Select a tool dialog box to be used. See the diagram below for the tool dialog boxes displayed by default. (See 4.8.)
(9)	VBA (macro)	Create new macros or bring up macros. (See 4.9.)
(10)	Window (Window operation)	Perform operations such duplicating and lining up image windows. (See 4.10.)
(11)	Help	Display EZ-C1 help or version information. (See 4.11.)

The structure and primary functions of tool dialog boxes are shown below.

	Name	Function Overview
(12)	Acquire Settings (1: Scan control)	<ul style="list-style-type: none"> - Start and finish scanning. - Select image acquisition mode. - Set the scanning area. - Set the laser irradiation time (scanning speed). - Set the acquisition resolution. - Select the objective data. (See 3.4)
	(2: Image acquiring mode settings)	<ul style="list-style-type: none"> - Average (acquire averaged image) - Channel Series (acquire images for each channel) - Z-stack (acquire XYZ images) - Time Series (acquire images at set intervals) (See 3.5.)
(13)	Laser and Detector (Detector status display)	For the spectral mode, the conditions of the laser shutter and the spectral detector for the spectral mode are displayed. For the standard mode, the laser shutter settings are specified here. (See 3.1.)
(14)	Laser and Detector Profile (Detector settings)	Set the laser shutter and the spectral detector for the spectral mode. (See 3.2.)
(15)	Gain Bar (Gain settings)	Adjust the Gain of each detector. (See 3.3.)
(16)	View Settings (Image Display)	<ul style="list-style-type: none"> - Info: (image information) - Color: (image colors and contrast) - View: (image display format (1D, 2D, or 3D)) (See 3.6.)

Note

To display another dialog box, select it from the Tools menu.

- A detailed description of the Laser Control Bar dialog box used to control the laser is given in Section (see 3.7).
- A detailed description of the Laser Power Monitor dialog box used to monitor the laser power is given in Section (see 3.8).

3

Common Tool Dialog Boxes

Chapter 3, “Common Tool Dialog Boxes” describes major functions.

3.1 Laser and Detector (Laser and Detector Status Display)

Use the Laser and Detector tool dialog box to make settings such as laser shutter and Pinhole settings.

Switching method: This dialog box appears automatically when the switch on the scan head is changed from the standard to the spectral mode.

Spectral Mode Setup

Use the Laser and Detector dialog box to set laser shutters, detector status, pinholes, transmission detector settings, etc for the spectral mode.

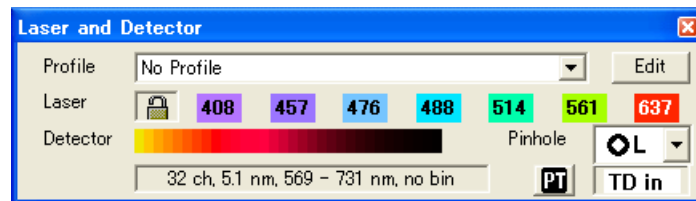











Figure 3.1-1 Laser and Detector dialog box for the spectral mode

Name	Function Overview
Profile settings View and select the hardware configuration file (Profile). Press the [Edit] button to make detailed settings.	
	Show the name of the current hardware configuration file (Profile). The pulldown menu shows the list of Profiles for the currently loaded Project file. “No_Profile” appears when no file has been selected.
 [Edit]	Set the spectral detector, laser shutters or other settings. The Laser & Detector Profiles dialog box closes.
Laser Shows laser shutter status.	
 Interlock	This icon indicates the state of the laser safety interlock state of the microscope. For safety, all laser shutters are closed when the microscope optical path is switched to enable eyepiece observations and this button  flashes. (Laser shutter opening/closing and image acquisition functions in applications are then not operational.) To return to confocal mode, press this button after switching the optical path of the microscope to confocal acquisition mode.

 <p>Laser shutter</p>	<p>Show currently selected laser shutter status.</p> <p>To set laser shutters in the spectral mode, use the Laser & Detector Profiles dialog box that appears when pressing the [Edit] button.</p> <ul style="list-style-type: none"> - The button indicates “laser wavelength” and its “color.” - Black buttons indicate buttons for lasers that have been closed. <p>! Lasers with a wavelength in the spectral detector wavelength range are indicated as disabled when a laser shield is not set.</p>
 <p>Detector</p>	<p>Show the status of currently selected detector.</p> <p>Shows the wavelength colors of the currently selected set wavelength range. The bottom field indicates Number of Channels, Resolution, Wavelength Range, Number of bins, and Bundle Number.</p> <p>! Skipped channels are not included in the Number of Channels. Resolution indicates the resolution for 1 binning channel when binning is selected.</p>
 <p>Pinhole</p>	<p>Set pinhole diameter.</p> <p>S (30um), M (60 um), L (100 um), O (150um)</p>
 <p>[PT]</p>	<p>Set up acquisition of transmission detector data.</p> <ul style="list-style-type: none"> - When ON (depressed), transmission detector data is acquired. - The “spectral data” and the “transmission detector data” are overlaid on the “C1 Spectral Live window”. <p>To configure the view for the transmission data, use the Transmitted tab of the View Settings dialog. (See 3.6.5 Transmitted Tab)</p> <p>For the spectral data, use the Color tab.</p> <ul style="list-style-type: none"> - When OFF (not depressed), transmission detector data is not acquired. <p>! This button appears when the motorized transmitted light detector is installed.</p> <p>When the manual transmitted light detector is installed, this button appears with the “Transmitted Detector is installed” check box selected in Configure Confocal C1 Standard Detector tab.</p> <p>! When transmission detector data is acquired by pressing this button, if spectral data is saved in ids format, transmission detector data is saved to another file at the same time.</p> <p>Example: <u>When spectral data is saved with the file name of “AAA.ids”, transmission detector data is automatically saved with the file name of “AAA TD.ids”.</u></p>
 <p>[TD in/out]</p>	<p>Use this button to switch the optical path when a motorized transmitted light detector is connected.</p> <ul style="list-style-type: none"> - When set to IN (depressed), the optical path is switched to the transmission detector. - When set to OUT (not depressed), the optical path is switched to the diascopic illumination lamp. <p>! This button appears only when the motorized transmitted light detector is installed.</p>

CAUTION

Please be sure to check that a transmitted illumination lamp is OFF before setting a Transmitted Light Detector to IN.

(When your microscope has a Motorized Transmitted Light Detector, please check before pushing the [PT] button or the [TD] button for making it IN. When your microscope has a Manual Transmitted Light Detector, please check before making it IN manually.)

However, if your microscope is a "Motorized microscope" and it has a Motorized Transmitted Light Detector then you can only push the [PT] button or the [TD] button for making it IN without consideration a transmitted illumination lamp is ON or OFF, it will turn OFF automatically.

Standard Mode Setup

Use the Laser and Detector dialog box to set laser shutters, pinholes and other settings for the standard mode.

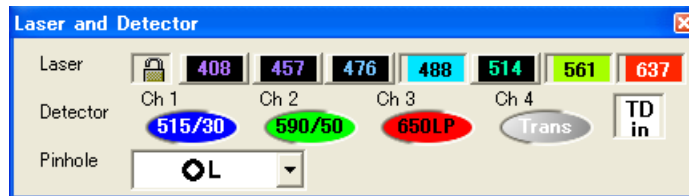

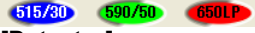
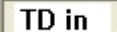



Figure 3.1-2 Laser and Detector dialog box

Name	Function Overview
 Interlock	– Functions the same way as in the spectral mode. –
 [Laser shutter]	Open and close the laser shutters. Turning this button ON and OFF switches the laser shutter between Close and Automatic. - The button indicates "laser wavelength" and its "color." - Black buttons indicate buttons for lasers that have been closed.
 [Detector]	Specify the channel to be refreshed. - When a channel is specified to be refreshed, its button is shown in a color of the channel display. When a channel button is shown in the black, the channel will not be refreshed. - The button indicates a "Label for each channel."
 [TD in/out]	– Functions the same way as in the spectral mode. –
 Pinhole	– Functions the same way as in the spectral mode. –

CAUTION

Please be sure to check that a transmitted illumination lamp is OFF before setting a Transmitted Light Detector to IN.

(When your microscope has a Motorized Transmitted Light Detector, please check before pushing the [PT] button or the [TD] button for making it IN. When your microscope has a Manual Transmitted Light Detector, please check before making it IN manually.)

However, if your microscope is a "Motorized microscope" and it has a Motorized Transmitted Light Detector then you can only push the [PT] button or the [TD] button for making it IN without consideration a transmitted illumination lamp is ON or OFF, it will turn OFF automatically.

3.2 Laser and Detector Profiles (Laser and Detector Settings)

The Laser & Detector Profiles dialog box provides functions for saving and loading hardware configuration files, functions for setting spectral data, functions for setting channel binning and other functions.

- Use the Detector tab to set spectral data and laser shutters.
- Use the Binning/Skip tab to set channel binning and masks.
- Use the Reference tab to set fluorescent stain by referencing.

Display method: Click the [Edit] button or the Wavelength color display in the Laser and Detector dialog box (see 3.1).

→The Laser & Detector Profiles dialog box opens.

CAUTION

- The Laser and Detector Profiles dialog box is not displayed in the standard mode.

3.2.1 Detector Tab

Use the Detector tab to make spectral detector settings. Select wavelengths in the wavelength range from 400 to 750 nm using the wavelength color for reference. Laser shutters can be opened simultaneously. Among the lasers for which the laser shutter has been opened, however, the laser that has the longest wavelength is provided with the laser shield, and the laser wavelength range shorter than the longest wavelength is limited as the range outside the acquisition area.

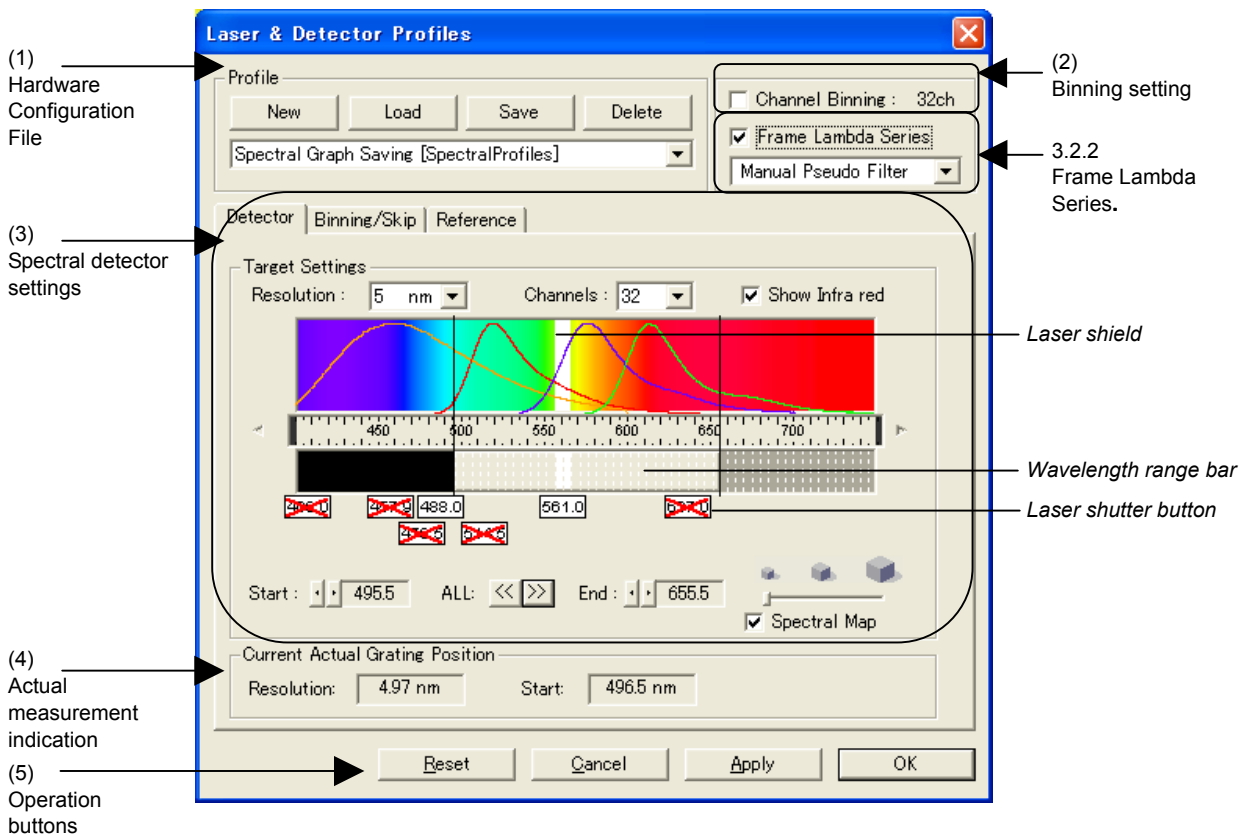

(1) Hardware configuration file

Use this function to save hardware configurations to file and load hardware configurations.

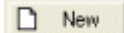
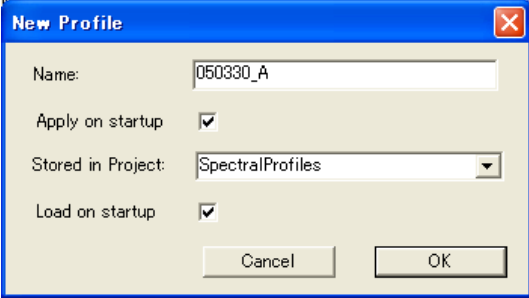
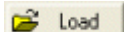
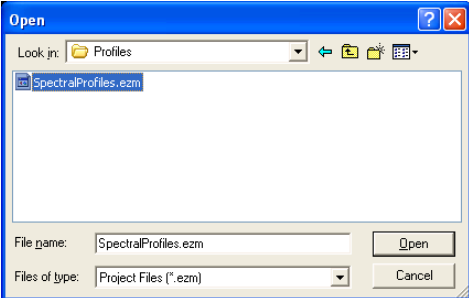
Name	Function Overview
 <p>Hardware configuration file</p>	<p>Displays the name of current hardware configuration file (Profile). Use the pulldown menu to show a list of configuration files (Profile) in Project files loaded using the [Load] button.</p> <ul style="list-style-type: none"> - The hardware configuration file stores the following information: <ul style="list-style-type: none"> - Wavelength resolution - Wavelength range - Number of acquired channels, mouse information, binning information - Used laser and shutter status - Laser shield range
 <p>[New]</p>	<p>Create a new hardware configuration file (Profile). Enter the Profile name and Project file name in the New Profile dialog box that appears.</p>  <p>Name: Enter the name of the hardware configuration file (Profile).</p> <p>Apply on startup: When selected, the Profile setting becomes the default setting when EZ-C1 is started up. When no Profile is selected, the most recently used Profile becomes the default.</p> <p>Stored in Project: Enter the name of the Project that is to store the Profile. SpectralProfiles.ezm is selected by default. Use this default setting unless a project is to be split up.</p> <p>Load on startup: When selected, Profiles in this project appear in the list of hardware configuration files when EZ-C1 is started up.</p>
 <p>[Load]</p>	<p>Read saved Project files (.ezm). The pulldown list of hardware configuration files shows a list of Profiles in Project files that are brought up by this command.</p> 

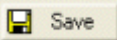
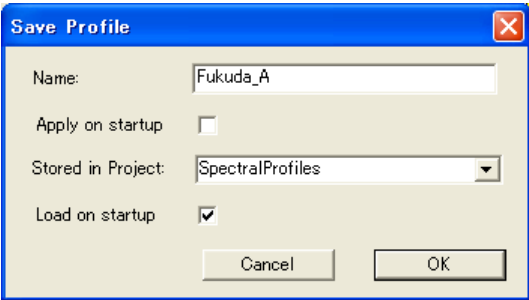
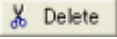
 [Save]	<p>Save current hardware configuration as a hardware configuration file (Profile). Press this button to save the settings.</p>  <p>Name: Enter the name of the hardware configuration file (Profile).</p> <p>Apply on startup: When selected, the Profile setting becomes the default setting when EZ-C1 is started up. When no Profile is selected, the most recently used Profile becomes the default.</p> <p>Stored in Project: Enter the name of the Project that is to store the Profile. SpectralProfiles.ezm is selected by default. Use this default setting unless a project is to be split up.</p> <p>Load on startup: When selected, Profiles in this project appear in the list of hardware configuration files when EZ-C1 is started up.</p>
 [Delete]	<p>Delete the current hardware configuration file (Project) from the Project file.</p>

CAUTION

<How to Load a Hardware Configuration File>

(1) Create settings when "No_Profile" is displayed.

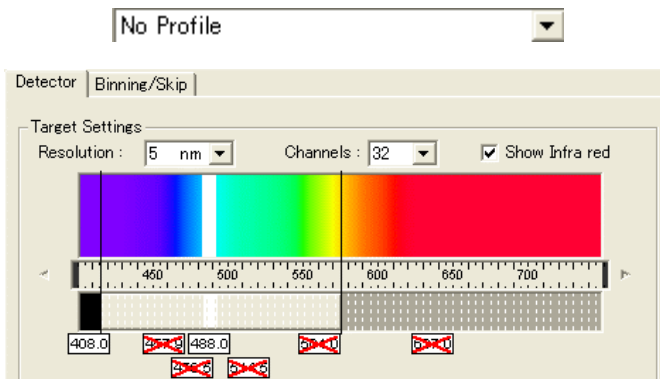

(2) Use the [Save] button to save the current Laser and Detector Profile dialog box settings.

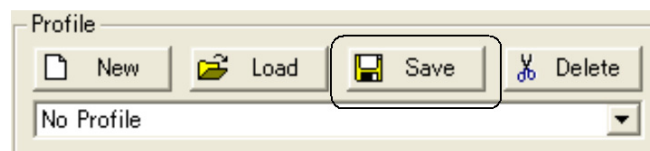

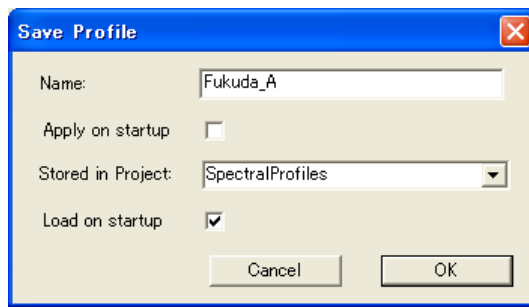

Name: Enter the name of the hardware configuration file (Profile).

Stored in Project: Leave the Project file in default status.

Use the [OK] button to save the settings.

Note: - When the settings have been changed, press [Save] again to save them.

- When a configuration file has been created using the **New** button and settings have been made in the Laser and Detector dialog box, be sure to press the **Save** button.

<How to Read Hardware Configuration Files>

- (1) Press the [Load] button and select the saved Project file (.ezm).

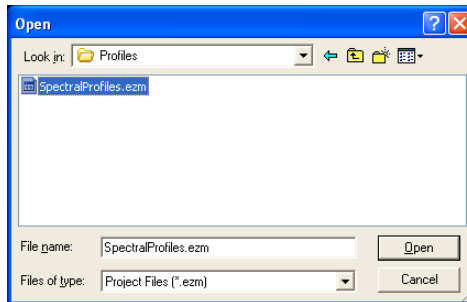

- (2) Use the Profile pulldown menu to show a list of hardware configuration files (Profile) in the selected Project file (.ezm). Select the Profile to be used.



(2) Binning setting

Use this setting to brighten a dark image by setting binning between channels. Use the Binning/Skip tab to make detailed settings. (See 3.2.3)

Name	Function Overview
<input type="checkbox"/> Channel Binning : Channel Binning check box	Set binning between channels. Select this check box to open the Binning/Skip tab and set the number of channels binned together.
Number of bins	Indicates the currently set number of channels. When binning is set, the number of channels after binning is also displayed.

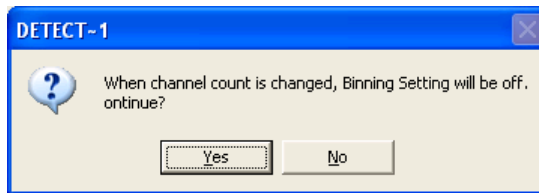

CAUTION

- Set laser shutters, resolution, and wavelength range (channels) before selecting this checkbox because any change in these settings will clear the checkbox.



(3) Spectral detector settings

Make spectral detector settings such as Resolution, Wavelength Range and Channels.

Name	Function Overview
Resolution	Set the resolution from 2.5, 5, or 10 nm.
Channels	Select the number of channels (number of PMT). A total of 32 channels can be selected in the 400 to 750 nm wavelength area.
Show Infra red	Select a wavelength color to display infrared light that is otherwise not visible to the naked eye. <ul style="list-style-type: none"> - When On, the wavelength color of the infrared area is brightly displayed. - When Off, the infrared wavelength is displayed in a color that is visible to the naked eye.
 Wavelength range bar	Set the wavelength range in the 400 to 750 nm wavelength area. Slide the wavelength range bar to the right or left to expand or contract the range. (This setting is interlocked with the Channels setting above.) ! Set a range of 420 to 750 nm when acquiring spectral data.
 [Laser shutter]	Set the shutter for the laser set in Configure Confocal C1 Laser tab. <ul style="list-style-type: none"> - The shutter is set to Automatic when the frame is filled with white. - The shutter is closed when X appears. ! Laser shutters can be opened simultaneously. Among the lasers for which the laser shutter has been opened, however, the laser that has the longest wavelength is provided with the laser shield, and the laser wavelength range shorter than the longest wavelength is limited as the range outside the acquisition area.
Start	Indicates the start wavelength in the currently selected wavelength range. Use the right and left buttons to expand or contract the range in units of resolution.
All	Shifts the wavelength to the right or left in the currently selected wavelength range without changing the wavelength width. The wavelength is shifted in 0.2, 0.5 and 1.0 nm increments at resolutions of 2.5, 5 and 10 nm, respectively.

End	Indicates the end wavelength in the currently selected wavelength range. Use the right and left buttons to expand or contract the range in units of resolution.
 Zoom setting	Zooms an image to one of three magnifications.
<input checked="" type="checkbox"/> Spectral Map Spectral Map checkbox	Turns the wavelength color display on or off.

CAUTION

- A laser shield is a screen that masks the longer wavelength laser when two laser shutters are open.

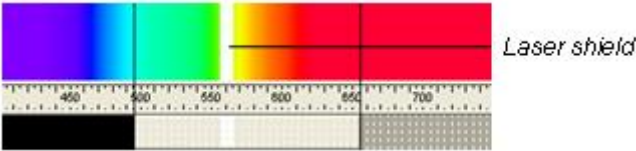

(4) Actual measurement indication

Indicates the actual hardware settings after the hardware has been set up.

Name	Function Overview
Resolution	Indicates the accurate resolution acquired by the hardware after pressing [Apply] or [OK].
Start	Accurate start wavelength acquired from the hardware after pressing [Apply] or [OK].

(5) Operation buttons

These buttons act on the spectral data settings made to the hardware.

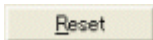
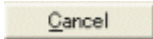
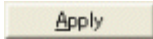
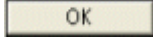
Name	Function Overview
 [Reset]	The current Profile is recovered. - This function is not available when "No_Profile" is displayed.
 [Cancel]	Cancels all changes and closes the dialog box.
 [Apply]	Applies the spectral detector settings to the hardware. The dialog box remains open. - Scanning and other operations are not available when this dialog box is open. - The Current Actual Grating Position group shows the resolution and start wavelength actually set as read from the hardware.
 [OK]	Applies the spectral detector settings to the hardware and closes the dialog box.

3.2.2 Frame Lambda Series

For sequential acquisition of spectral image data while switching lasers, from the longest to the shortest wavelength.

Frame Lambda Series

- Spectral Overlap: Switches the laser in descending order of the wavelength to obtain spectral data. (See 3.2.2.1)
- Auto Pseudo Filter: Switches the laser in descending order of the wavelength to obtain band pass data that uses the regions between excited laser wavelengths as 1ch. (See 3.2.2.2)
- Manual Pseudo Filter: Switches the laser in descending order of the wavelength to obtain band pass data that uses the free wavelength regions as 1ch. (See 3.2.2.3)

CAUTION

- The "Frame Lambda Series" check box setting is linked to the [Fr Lambda] observation button in the Acquire Settings dialog box in spectral mode.
- When Frame Lambda is selected, Binning mode is not available.

3.2.2.1 Sequential Acquisition of Spectral Data

Sequential scanning is performed while switching lasers from the longest to the shortest wavelength. Then, one spectral data is obtained after the scanning results are integrated.

Use the following procedure to specify settings in the Laser and Detector Profile dialog box:

1. Select the "Frame Lambda Series" check box.
2. Select "Spectral Overlap".
3. Select a laser to be used, and then set the shutter to Automatic.
4. Specify a wavelength range using the wavelength range setting bar.
5. Select [OK] or [Apply].

Then, a pass is automatically created to the Frame Lambda tab in the Acquire Settings dialog box.

The pass settings are as follows:

1. Lasers of consecutively shorter wavelengths are configured for each pass, starting with Pass 1.
2. In each pass, data is acquired in a range starting at the excitation laser wavelength and ending at the final edge of the wavelength range.

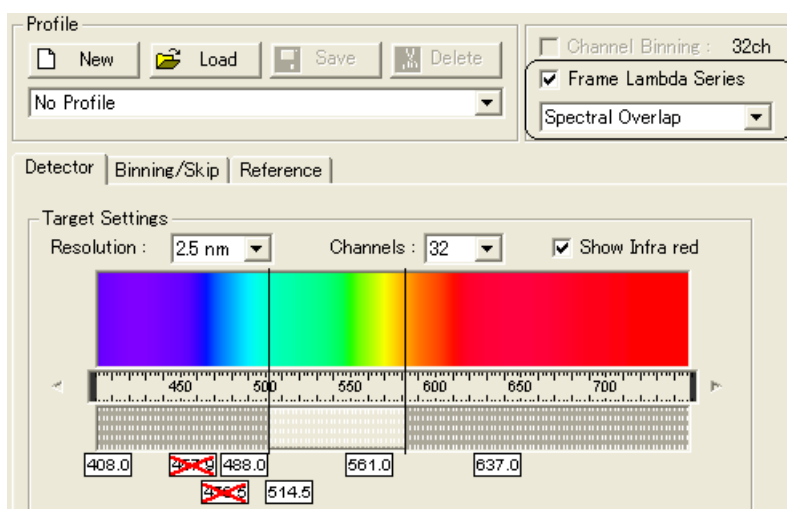

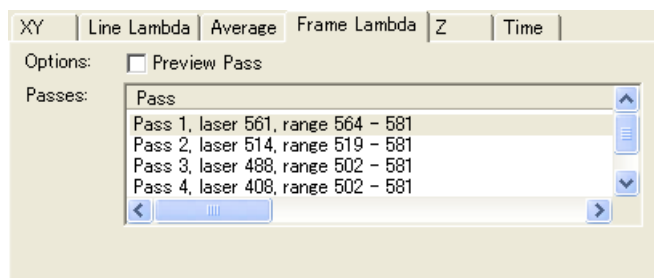
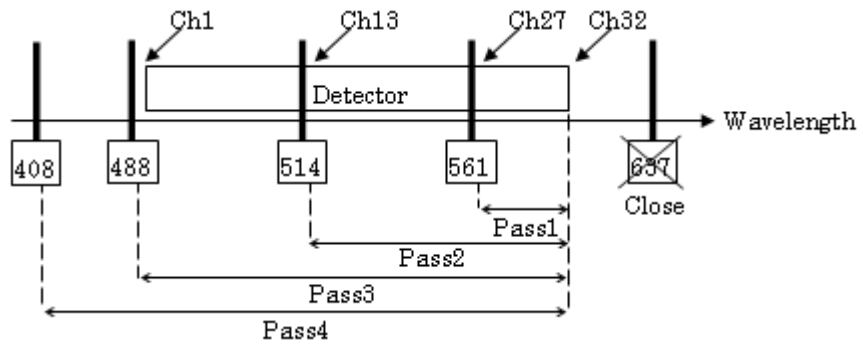

CAUTION

- The laser shutter is closed for wavelengths longer than the 32nd channel acquisition range and not included in a pass.
- Select [PT] on the Laser and Detector dialog to set transition detector data acquisition for the currently selected pass.

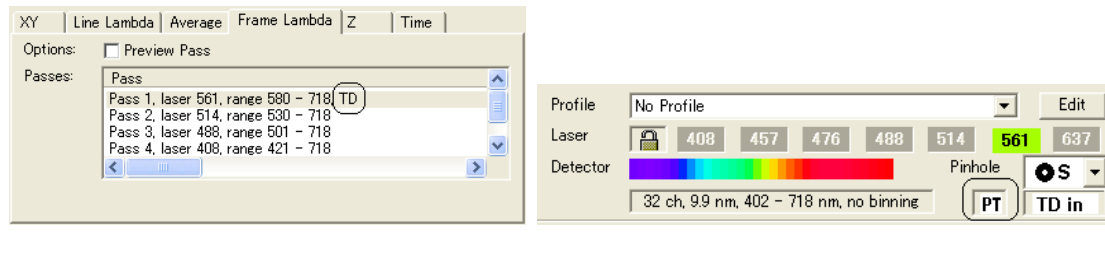

Name	Function Overview
Spectral Overlap	The laser is switched over for sequential acquisition of the spectral data. <ul style="list-style-type: none"> - The laser switches over in descending order of the wavelength. - In each pass, spectral data is acquired in a range starting at the laser wavelength and ending at the final edge of the wavelength range. Data obtained for all the passes are integrated and displayed as a single spectral data.

3.2.2.2 Sequential Acquisition of Band Pass Data (Auto Setting)

Sequential scanning is performed while switching lasers from the longest to the shortest wavelength, to obtain band pass data that uses the regions between the excited laser wavelengths as 1ch. (The band pass data is obtained by integrating the spectral data.)

Use the following procedure to specify settings in the Laser & Detector Profiles dialog box:

1. Select the "Frame Lambda Series" check box.
2. Select "Auto Pseudo Filter".
3. Select a laser to be used, and then set the shutter to Automatic.
4. Specify a wavelength range using the wavelength range setting bar.
5. Select the "Auto" check box.
6. Select [OK] or [Apply].

After the above procedure is finished, a pass is automatically created to the Frame Lambda tab in the Acquire Settings dialog box.

The pass settings are as follows:

1. Lasers of consecutively longer wavelengths are configured for each pass, starting with Pass 1.
2. In each pass, data is acquired in a range from the excited laser wavelength to the next smallest excited laser wavelength.

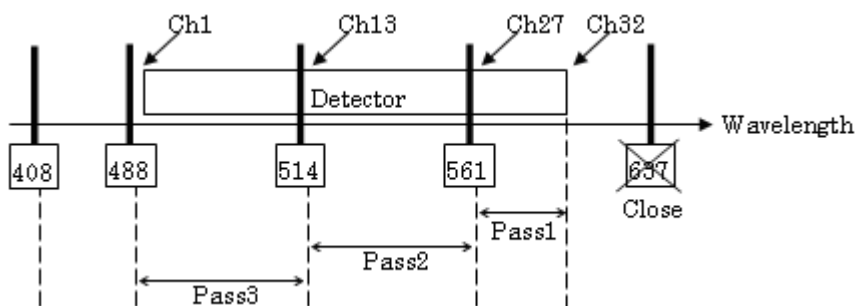
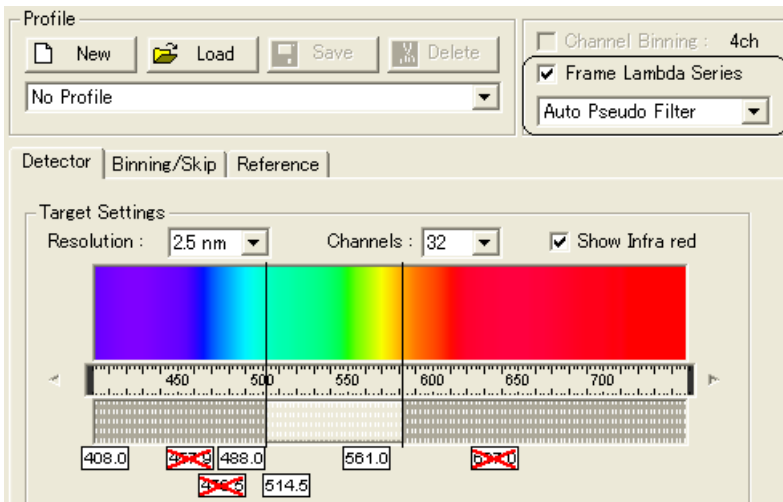

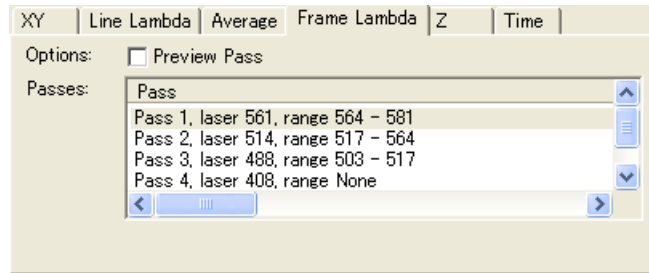

Caution

- For short wavelength lasers outside the acquisition range, data can not be acquired when the setting indicates that no detector exists between the laser wavelengths.

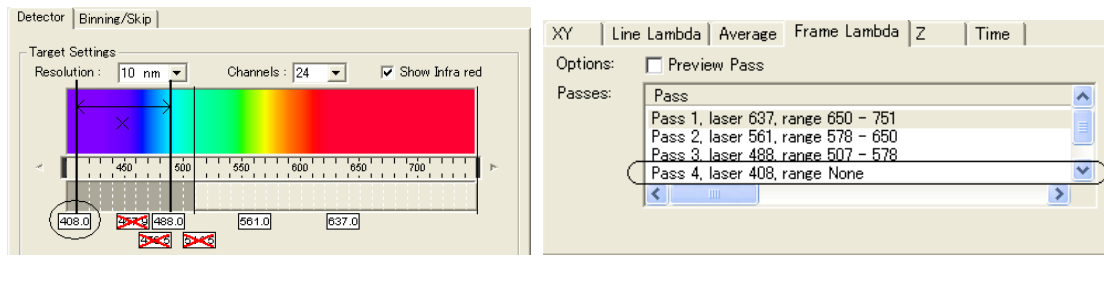

Name	Function Overview
<p>Auto Pseudo Filter</p>	<p>The laser is switched over to automatically obtain the band pass data for the specified range.</p> <p>Based on the detector range, the wavelength region between the excited laser wavelengths is obtained as the 1ch data.</p> <ul style="list-style-type: none"> - The laser switches over in descending order of the wavelength. - In each pass, band pass data is acquired for a range starting at the laser wavelength and ending at the final edge of the wavelength range. <p>A channel data is acquired for each pass.</p> <p>! Enabled only when Frame Lambda Series is ON.</p>

3.2.2.3 Sequential Acquisition of Band Pass Data (Manual Setting)

Sequential scanning is performed while switching lasers from the longest to the shortest wavelength, to obtain band pass data that uses a free region for each excited laser wavelengths as 1ch. (The band pass data is obtained by integrating the spectral data.)

Use the following procedure to specify settings in the Laser & Detector Profiles dialog box:

1. Select the "Frame Lambda Series" check box.
2. Select "Manual Pseudo Filter".
3. Select a laser to be used, and then set the shutter to Automatic.
4. On the laser tab for each excited laser, specify the wavelength range.
5. Select [OK] or [Apply].

After the above procedure is finished, a pass is automatically created to the Frame Lambda tab in the Acquire Settings dialog box.

The pass settings are as follows:

1. Lasers of consecutively longer wavelengths are configured for each pass, starting with Pass 1.
2. For each pass, data is acquired for the wavelength range specified for each excited laser.

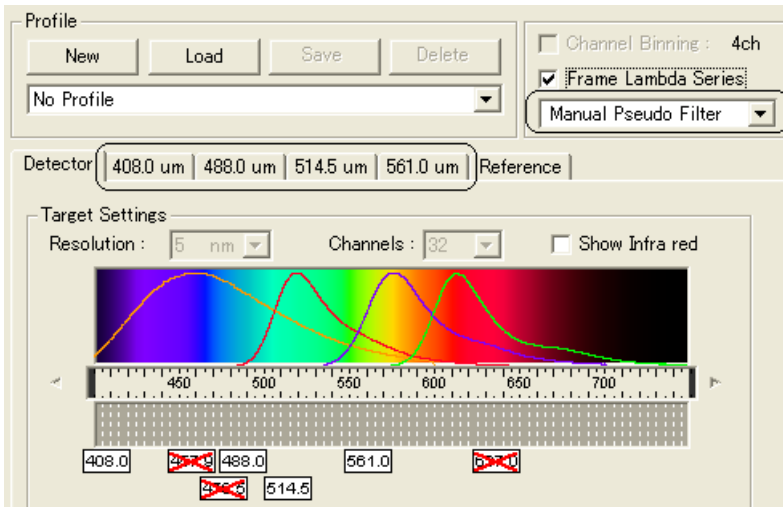

Settings with 408 laser:

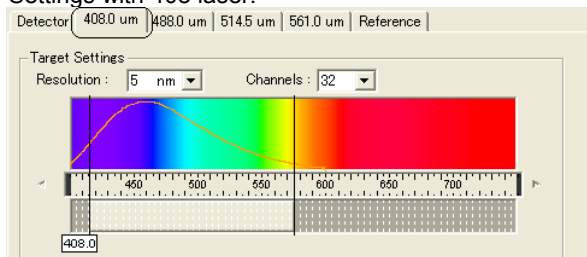

Settings with 488 laser:

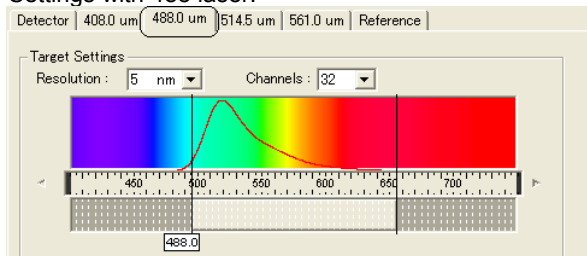

Settings with 514 laser:

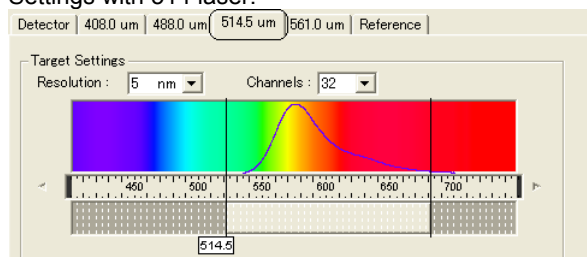

Settings with 561 laser:

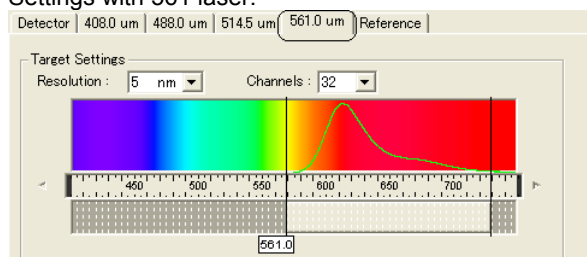

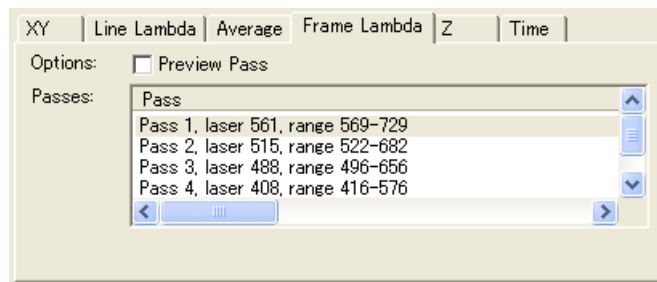
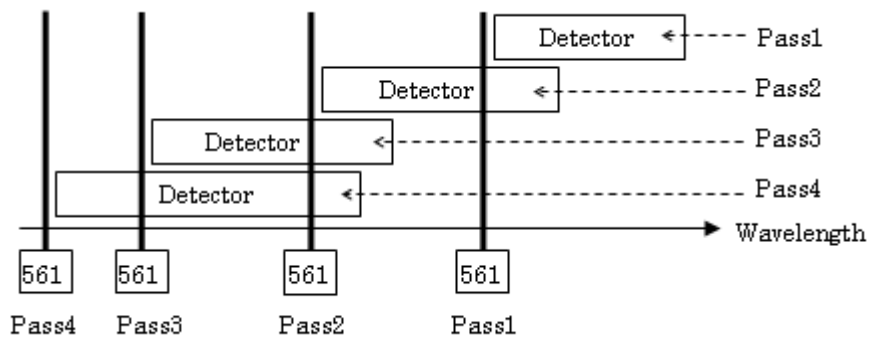

Caution

- On each laser tab, the spectral graph set on the Reference tab will be shown as the reference data. (See 3.2.4 Reference Tab).

Name	Function Overview
Manual Pseudo Filter	<p>The laser is switched over to obtain the band pass data for the specified range. The band range can be set freely for each excited laser.</p> <ul style="list-style-type: none"> - The laser switches over in descending order of the wavelength. - In each pass, band pass data is acquired for the user-specified range. A channel data is acquired for each pass. <p>A channel data is acquired for each pass.</p> <p>! Enabled only when Frame Lambda Series is ON.</p>

3.2.3 Binning/ Skip Tab

Use the Binning/Skip tab to make channel binning settings. Perform settings in this tab after confirming settings in the Detector tab.

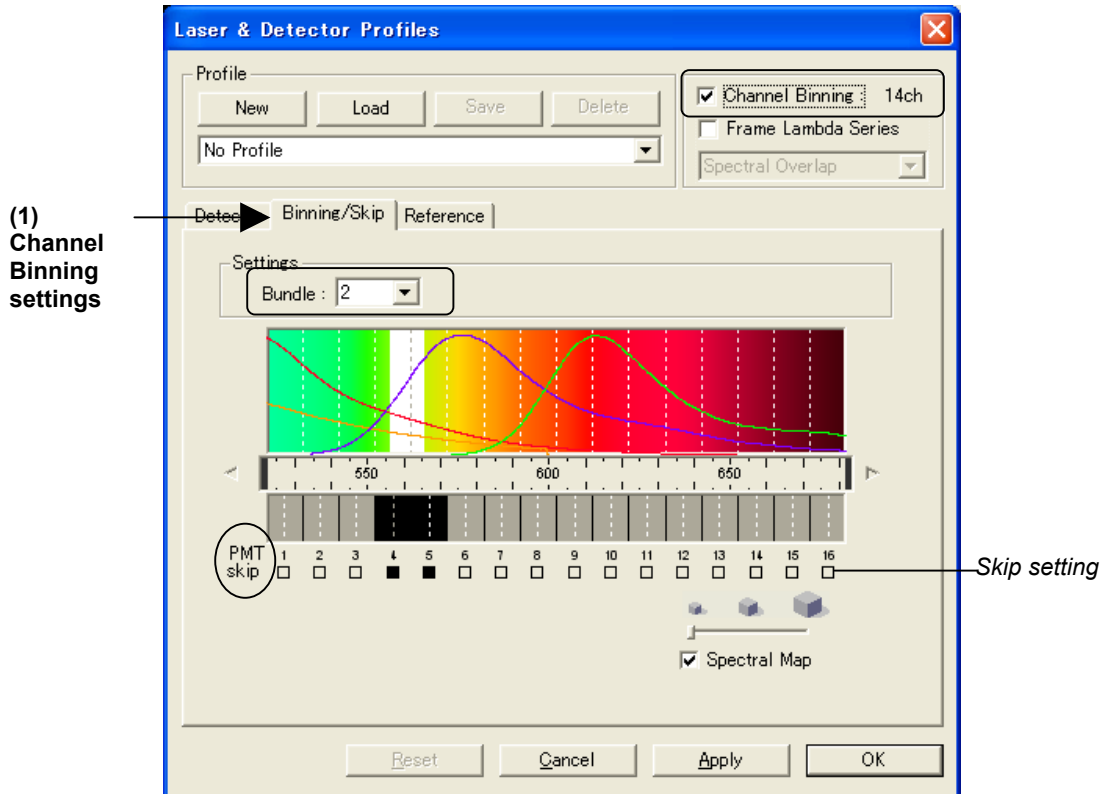

(1) Channel binning setting

Use this function to set channel binning to brighten dark images.

Masks can also be set to skip any channel in the wavelength range. Masking lowers the data volume since no data is acquired from masked channels.

Name	Function Overview
Bundle	Sets the number of channels to be binned into a single channel. Between two to four channels can be binned. ! This setting is available only when the Channel Binning checkbox in the top right corner is selected.
Skip	Make skip settings for each channel. Click to turn respective box ■ (black) to skip a channel. No data is acquired during a scan from channels that are set to be skipped.

CAUTION

- When a number is set in Bundle, the number of channels set in the Detector tab is automatically changed to the nearest number that is divisible by the number of bundles.
- A change in Detector tab settings clears the Binning/Skip tab settings (Channel Binning checkbox).

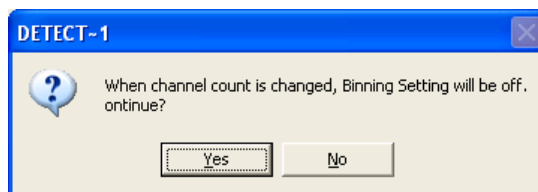

3.2.4 Reference Tab

Use the Reference tab to set spectral data files (text files) for the fluorescent stains to be acquired. As a result, a reference graph will be displayed on the Detector tab, Binning/Skip tab, and the laser tabs for Frame Lambda Series in Manual mode.

The graph servers as a reference when setting a wavelength range to the acquired. A spectral graph can be linked to an excited laser.

The following graphs can be displayed.

- Spectral graph for reference data (supplied from Molecular Probe or CLONTECH)
- Spectral graph for a spot of EZ-C1 image data (from a saved data file)

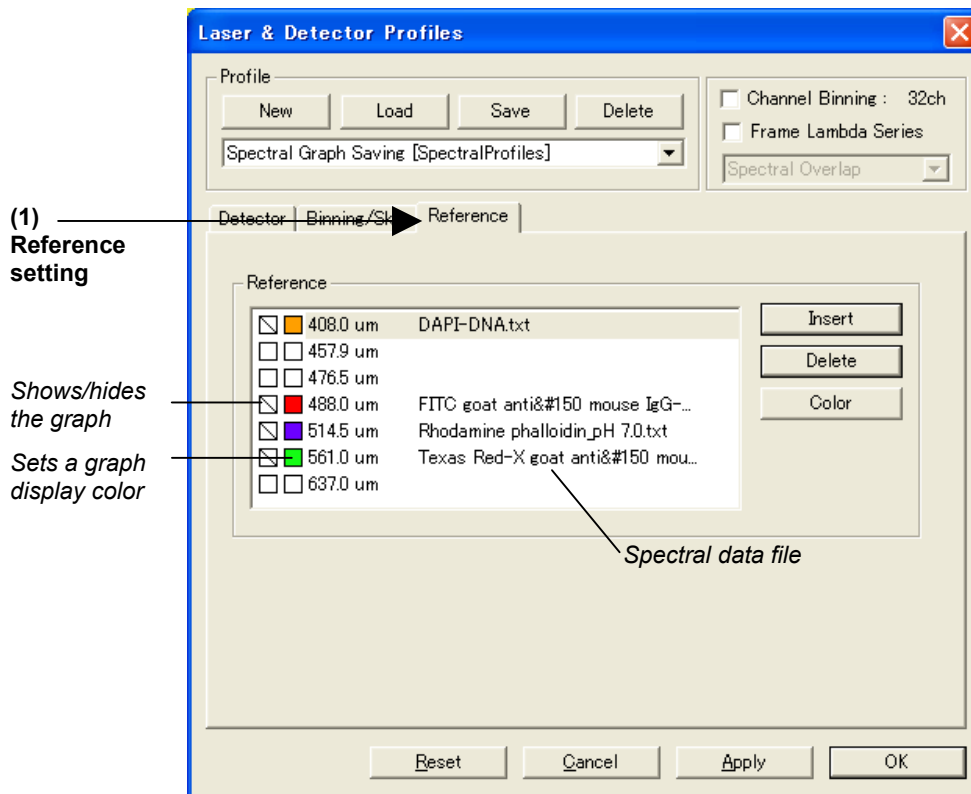

Detector tab

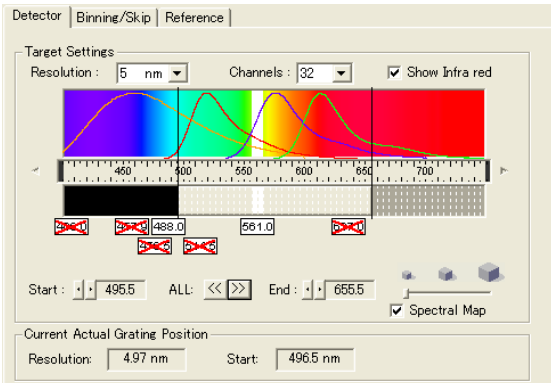

Binning/Skip tab

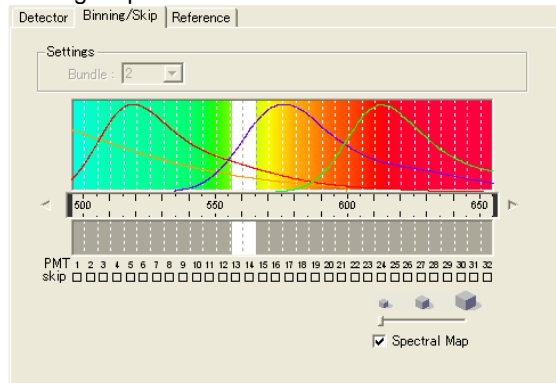

Laser Wavelength Tab (Frame Lambda Seires – “Manual” Setting)

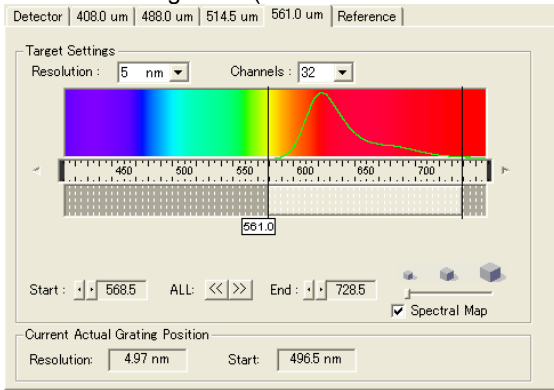

(1) Reference setting

The Reference tab configures the settings for the spectral graphs to be displayed in the Detector tab and Binning/Skip tab.

Up to seven spectral data files to be referenced can be set.

Once set here, the reference information can be saved as a profile for future restoration.

Name	Function overview
Show/hide box	Shows/hides the graph. Turning on this check displays a graph in the wavelength color display area of the Detector tab and Binning/Skip tab.
Display color box	Determines the graph display color.
[Insert]	Selects the spectral data files to be displayed. Pressing the [Insert] button displays a file name selection dialog box, and you can select desired files. The “Reference” list displays the file names as they are selected. ! Alternatively, a file selection dialog box can also be opened by double-clicking a blank area of the list.
[Color]	Determines the graph display color. Pressing the [Color] button displays a color dialog box, and you can select a desired color. The selected color appears in the display color box of the “Reference” list. ! Alternatively, the color dialog box can also be opened by double-clicking the display color box in the left of the list.
[Delete]	Deletes any files listed in the list.

CAUTION

- The spectral data that can be displayed for Reference setting comes from text files of the formats listed below.
 - (1) Spectral data exported with the DataSeries function of EZ-C1 (see Section 4.7.7, "Saving Graphs")
 - (2) Reference data made available in advance by EZ-C1
 Be aware that no other formats are supported.

Item (as displayed in the header)

	Excitation wavelength [nm]	Excitation intensity or absorptance	Fluorescence wavelength [nm]	Fluorescence intensity	Wavelength interval [nm]
(1) EZ-C1 Export data	-	-	wl	em	res
(2) Clontech data	wl	Ex	wl	em	-
Type 1	-	-	wl	em	res
Type 2	-	-	wl	em	res
Molecular Probes data	wl	abs	wl	em	-
Type 1	wl	abs	wl [space]	em	-
Type 2	wl	abs	wl [space]	em	-
Type 3	wl	ex pH 5.5	wl	em pH 5.5	-
Type 4	wl	ex pH 9	wl	em pH 9	-
Type 5	wl	ex/zero Ca	wl	em/zero Ca	-
Type 6	wl	ex/high Ca	wl	em/high Ca	-

- If no profile is selected (indicated as "No Profile") when exiting the Laser & Detector Profile dialog box by pressing [OK], a message appears prompting for your confirmation to save setting information to a profile. Select [Yes], and in the New Profile dialog box that appears, enter a profile name and select a destination file.

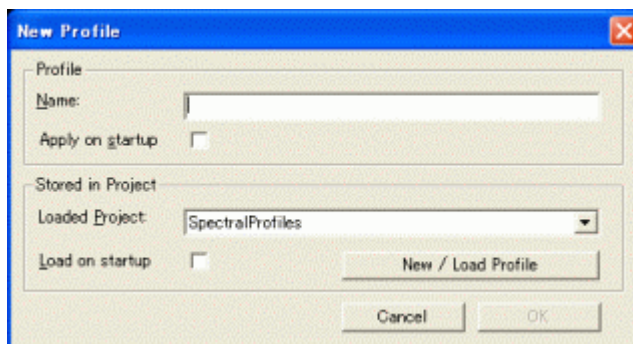

3.3 Gain Bar (Gain Setting)

3.3.1 Gain Tab

Use the Gain tab of the Gain Bar tool dialog box to adjust the gain (i.e., the voltage to be applied to the photo multipliers (PMTs)).

Switching method: This dialog box appears automatically when the switch on the scan head is changed from the standard to the spectral mode.

Spectral Mode Setup

The spectral detector gain bar appears when the spectral mode is invoked and the transmission detector gain bar appears when transmission detector data is acquired.

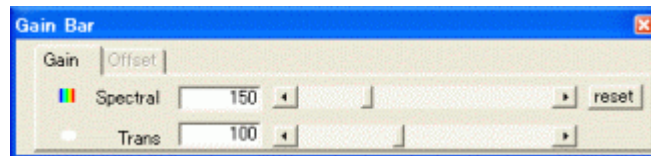





Figure 3.3-1 Gain Bar dialog box

Name	Function Overview
 Spectral Spectral Detector Gain Bar	Adjusts Spectral Detector gain for all 32 PMTs. HV can be adjusted to a value between 400 to 900 V. Values are indicated in 255 increments. ! If HV is set to 700 V or more to acquire spectral data, PMT noise increases and accuracy of brightness calibration may decrease. 700 V is represented as "198".
 [reset]	When the gain voltage is set too high for the intensity of light reaching the PMT, the gain voltage is forcibly shut down to protect PMT. When this occurs, the reset button flashes red. Press the flashing button to readjust the gain. (The value returns to 0 after the reset for safety reasons.)
 Transmission Detector Gain Bar	Adjusts the gain of the transmission detector. ! The image window flashes when too much gain is applied to the transmission detector. The flashing stops when the gain is reduced to permissible levels.

CAUTION

- The transmission detector Gain Bar is available only when the [PT] button in the Laser and Detector tool dialog box is ON (when the transmission detector is set up to acquire data). It does not appear when this button is OFF.

Standard Mode Setup

The Gain Bar for each detector channel appears in the standard mode.

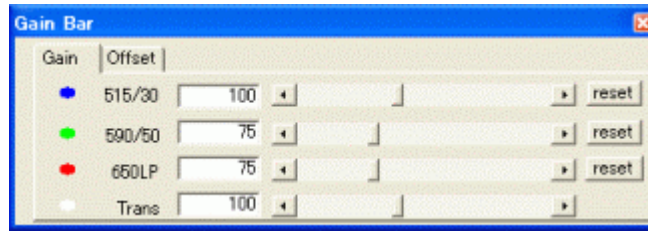







Figure 3.3-2 Gain Bar dialog box

Name	Function Overview
 515/30  590/50  Gain Bar for the standard detector	Adjusts the gain for each standard detector that is the gain for all PMTs. HV can be adjusted from 0 to 1250 V. Values are indicated in 255 steps.
 [reset]	– Functions the same way as in the spectral mode. –
 Trans Transmission detector Gain Bar	– Functions the same way as in the spectral mode. –

CAUTION

- The transmission detector Gain Bar dialog box appears when “Trans” is set in Order in the Configure | Confocal C1 | Standard Detector tab (and transmission detector data is acquired). It is not available when “Trans” is not set.
- The data appears in the order selected in Configure | Confocal C1 | Standard Detector tab.
- When the Linear Gain Mode in the Configure | Confocal C1 | Standard Detector tab is on, gain values are indicated as logarithmic values (for example, 0.15B = $10^{0.15}$ or 5.0B = $10^{5.0}$).

3.3.2 Offset Tab

Use the Offset tab of the Gain Bar tool dialog box to set offset values for the voltages output from the photo multipliers (PMTs).

Gains can only be set with the PMTs in the standard mode.

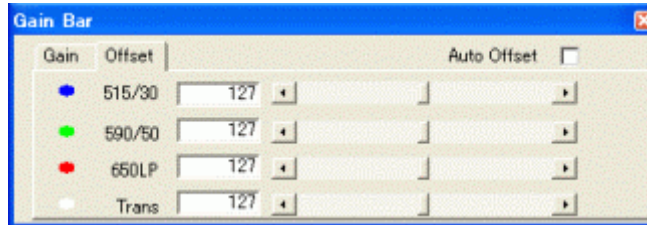

Figure 3.3-3 Offset tab of Gain Bar dialog box

Name	Function overview
<ul style="list-style-type: none"> ● 515/30 ● 590/50 ● 650LP <p>Offset Bar for the standard detector</p>	<p>Adjusts the offset value for the PMT output voltage of each standard detector. Values are indicated in 255 steps.</p>
<ul style="list-style-type: none"> ● Trans <p>(Transmission Detector Offset Bar)</p>	<p>Adjusts the offset value for the PMT output voltage of each transmission detector.</p>
<p>Auto Offset</p>	<p>Sets the offset values for PMT output voltage based on the PMT Calibration data created by the Offset Calibration function.</p> <p>! The C1 Offset Calibration dialog box opens if PMT calibration data has not been created yet. For all PMTs excepting one for the transmission detector, the offset values for PMT output voltage are measured by adjusting gain and pixel dwell, until a calibration table is created. (Incident light to the PMT must be blocked when creating this calibration table.)</p> <p>! For the C1 Offset Calibration dialog box, see the description of the [Auto Offset] button in Section 5.2.8, "Standard Detector Tab."</p>

CAUTION

- The offset value for PMT output voltage of the transmission detector can only be adjusted manually. It cannot be adjusted automatically by the Offset Calibration function.

3.4 Acquire Settings (1: Scan control)

3.4.1 Acquire Settings dialog box

The Acquire Settings dialog box (Figure 3.4-1) is used to control image acquisition. The Acquire Settings dialog box is displayed by selecting Acquire Settings from the Tools menu.

Images can be acquired in various ways depending on the selected image acquisition mode. Check the checkbox for the desired image acquisition mode in the Acquire Settings tool to set the parameters for each mode. (See 3.5 “Acquire Settings (2: Image acquiring mode settings)”.) You can check multiple checkboxes to enable a combination of multiple acquisition modes. Note that the order of processing is set such as first Average, then Z-stack, and finally Time.

Keep in mind that if no image acquisition mode or line scan option is selected, 2D images are acquired (X and Y) one slice at a time.

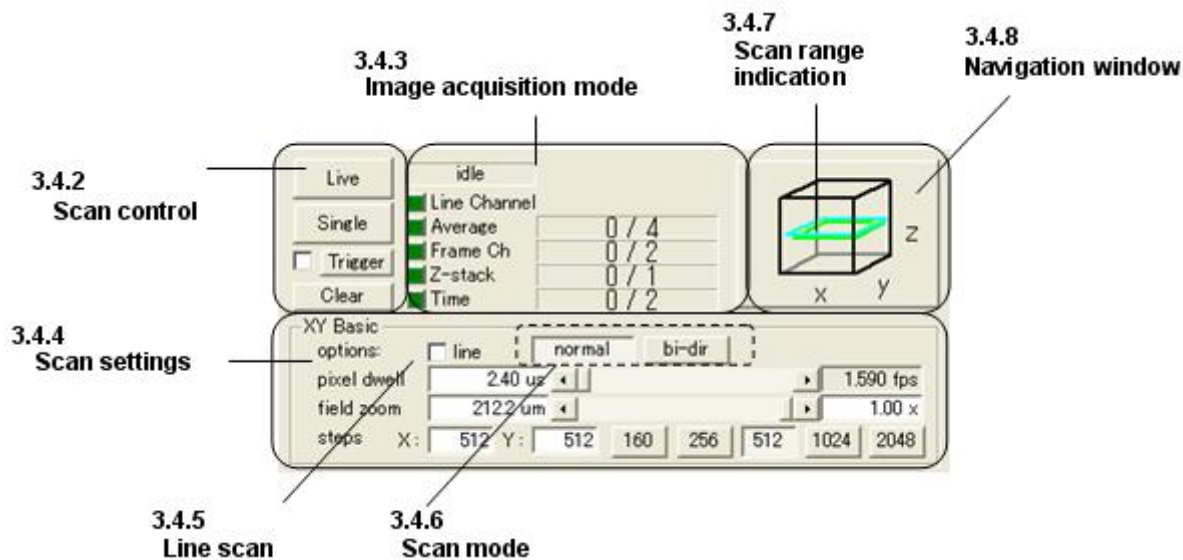
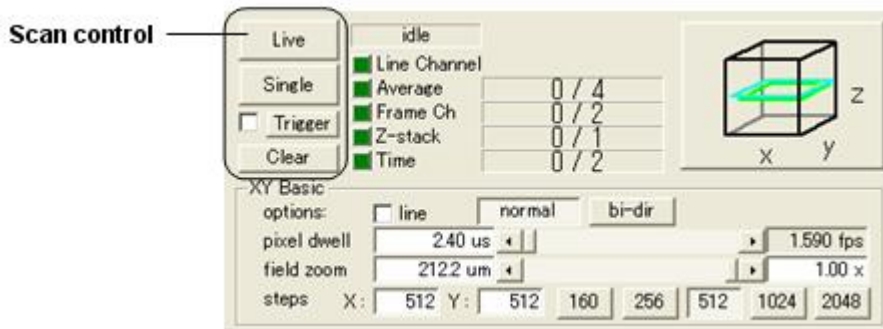

Figure 3.4-1 Acquire Settings dialog box

3.4.2 Scan Control

The Scan control contains the following buttons.



Name	Function Overview
<input type="button" value="Live"/>	Press this button to start or stop image acquisition. Images are repeatedly acquired until the [Live] button is pressed again.
<input type="button" value="Single"/>	Press this button to start image acquisition in a single sequence. Searching will stop after a full scan is completed.
<input type="checkbox"/> Trigger	This check box is checked to allow input of a trigger signal. Image input is started after receiving a trigger. (See 3.4.2.1)
<input type="button" value="Clear"/>	Press this button to clear the image data displayed on the selected window.

CAUTION

- Note that the above buttons perform different functions, depending on the image acquisition mode selected. See 3.5 for more information of each mode.

3.4.2.1 Trigger Settings

To input trigger signals, enable the Trigger checkbox in the Acquire Settings dialog box. By using the [Trigger] button, trigger settings can be made. In the Trigger function, an image acquisition starts triggered by a trigger signal. (This function is only available when the trigger device is set.)

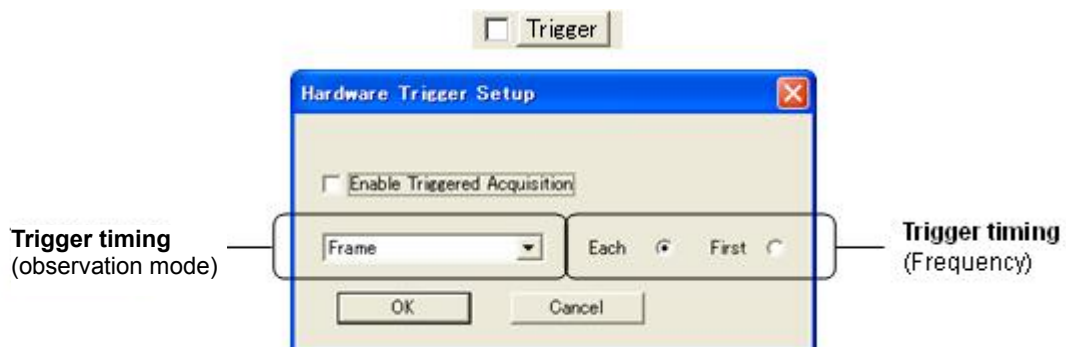

Figure 3.4-2 Trigger Setup dialog box

The Trigger Setup dialog box provides the following functions.

Name	Function Overview
Enable Triggered Acquisition	Enable or disable the Trigger function. This checkbox is changed together with the checkbox in the Acquire Settings dialog box.
Trigger timing (observation mode) Frame/ Average/ Channel/ Z-Stack/ Time Series	The observation mode is set as a trigger timing. (See Note below.) Frame: Waits a trigger for each frame acquisition. Minimum unit for a trigger timing. Average: Waits a trigger for each Average image acquisition when the Average mode is selected. Channel: Waits a trigger for each Channel Series image acquisition when the Channel Series mode is selected. Z-Stack: Waits a trigger for each Z-Stack image acquisition when the Z-Stack mode is selected. Time Series: Waits a trigger for each Time Series image acquisition when the Time Series mode is selected.
Trigger timing (Frequency) Each/ First	Select a trigger timing according to the observation mode specified above. Each: Waits a trigger for each observation mode when the selected mode is executed. First: Waits a trigger for each observation mode when the selected mode is started.

Note

- If the selected observation mode is not used, a trigger waiting is not performed.
- Start trigger setting when the observation mode is used:
Set "the observation mode" and "First" when the observation mode is used.
Set "the observation mode to be executed last" and "First" when multiple observation modes are set. Note that the "execution order" of the observation mode is as follows: Average, Channel, Z-stack, and Time Series.
- Trigger setting when the observation mode is not used:
Set "Frame" and "Each" or "First" when Single scanning is performed without using the observation mode.
If "Frame" and "Each" or "First" is set when Live scanning is performed without using the observation mode, trigger waiting is performed for each frame.

Example) When the Z-stack mode and Time Series mode are used:

To set a start trigger only: "Time Series" and "First"

To set a trigger for each interval of the Time Series mode: "Time Series" and "Each"
(="Z-Stack" + "First")

To set a trigger for each Z slice of the Z-Stack mode: "Z-Stack" and "Each"

3.4.3 Image Acquisition Modes

The Acquire Settings dialog box offers the following image acquisition modes.

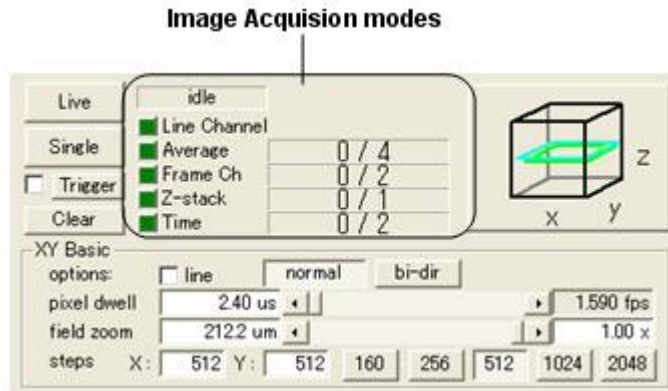

Name	Function Overview
Idle field	Displays the scanning status or warnings. Idle: Scanning stops. Scanning: Scanning ! When a long period of time is set for “pixel dwell,” if the scan speed becomes 0.5 fps or lower, the progress bar is displayed. The progress bar shows which line is being scanned in one frame.
Line Channel	Acquires the frame data while switching PASS (shutter, channel) when each line is scanned. (See 3.5.2)
Average	Averages the acquired image to improve signal-to-noise ratios. (See 3.5.3)
Frame Channel	Acquires the frame data while switching PASS (shutter, channel, or pinhole) for each frame. (See 3.5.4)
Z-stack	Allows 3D (X, Y, and Z) image acquisition (available only when Z-drive RFA or Microscope TE2000-E is selected for Devices in the Configure menu; see 3.5.5).
Time (Time Series)	Records from 1D to 3D time series images. (See 3.5.6)

CAUTION

- For information on Image Acquisition modes, refer to Section 3.5, “Acquire Settings” (2: Image acquiring mode settings).

3.4.4 Scan Settings

The Scan control on the Acquire Settings dialog box (see 3.4.1) are used to set the scan period, field of view, and scan resolution. The field of view and position are displayed in μm . For a correct display of the physical distances, the correct objective power is required.

Scan settings are following setting items.

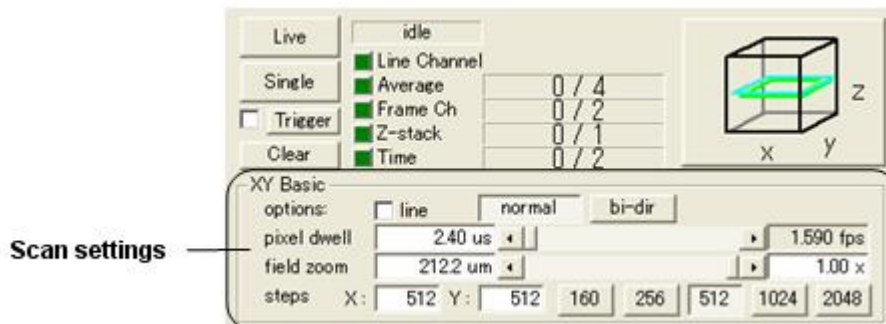

Name	Function Overview
line	This option acquires a mono-dimensional image in the X direction. The laser executes scanning lines along with the X-axis (see 3.4.5).
[normal]	Scanning is performed in the normal scan mode (see 3.4.6.1).
[bi-dir]	Scanning is performed in the bi-directional scan mode (see 3.4.6.2). ! This function is not available in the spectral mode.
pixel dwell	In this field, set a laser irradiation time for each pixel. If the amount of light is small, the period is increased and the signal is integrated for an extended period of time. On the right side of the scroll bar, "a number of acquired frames per one second" is displayed. ! The minimum period of time for the laser irradiation time setting varies between in normal scan and bi-directional scan ! Set this function to a range between 4 to 30 μs in the spectral mode.
field zoom/ crop	Decrease the field of view to zoom in. Increase the field of view to zoom out. Alternatively, click on the zoom icon  using the mouse to specify a new field of view and position. On the right side of the scroll bar, "a zoom ratio" is displayed. The ratio can be set by entering a value ! When Zoom is selected on the XY tab, "field zoom" is displayed. When Crop is selected, "field crop" is displayed.
steps	Select the number of pixels along the X and Y-axes. Press the [160], [256], [512], [1024], or [2048] button to obtain the square images with the indicated number of pixels. A number of pixels for 16 pixel step can be entered in the X or Y text box. ! Only [256] or [512] can be set for X in the bi-directional scan mode. ! [2048] cannot be set in the spectral mode.

3.4.5 Line Scanning

Enable the line checkbox in the Acquire Settings dialog box to perform the Line scanning. In the Line scanning, a scan is performed along the X-axis and then one-dimensional image in the X direction is acquired. Set the Y position of this line by using the Y position on the Navi tab or the Navigation window.



Note

- The Live window shows an 1D graph or 2D image according to the View setting in the View Settings window. The 2D image is the image which displays the acquired line image in the Y direction in time sequence.
- Line scanning is not possible for Z stack observation.

3.4.6 Scan Mode

“The normal scan mode,” and “bi-directional scan mode” are switched by using the [normal] or [bi-dir] button in the Acquire Settings dialog box. The scanning speed becomes faster in the following order: “the normal scan mode” and “bi-directional scan mode.”

Caution

- Only the normal scan mode is available in the spectral mode.

3.4.6.1 Normal Scan Mode

The scanning is performed in the normal scan mode.

A small rectangular button with the text "normal" inside.

Name	Function Overview
[normal]	Scanning is performed in the normal scan mode. (Maximum scanning speed: approx. 1.0 f/s at 512 x 512) Data of the maximum field of view can be acquired.

3.4.6.2 Bi-directional scanning

Scanning is performed in the bi-directional scan mode.

To set the bi-directional scan mode, select the [bi-dir] option in the Acquire Settings dialog box or the Bi-Directional option in the Bi-Directional Scan bar (see 3.4.9). In the single directional scanning, the laser scans in only outgoing path. In the bi-directional scan mode, both the outgoing and return paths are scanned. This reduces the time required for scan acquisition.

A small rectangular button with the text "bi-dir" inside.

Name	Function Overview
[bi-dir]	Scanning is performed in the bi-directional scan mode. ! This function is not available in the spectral mode.

CAUTION

- Single directional scanning and bi-directional scanning

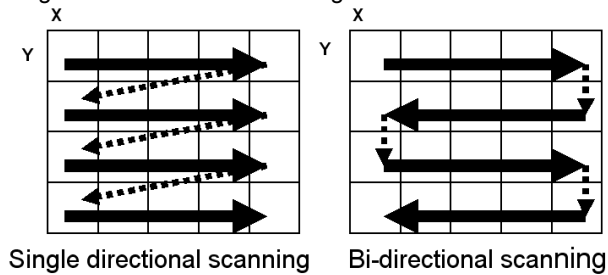

Bi-directional scanning:

- When the bi-directional scanning is performed, image shift occurs between the left-to-right scan and the right-to-left scan. This shift can be corrected with the Adjust Scan setting on the Bi-Directional Scan bar. (See 3.4.9.) Correct the shift while checking the image. Twenty correction values can be saved for twenty sizes of field zoom. (See 3.4.4.) The saved correction value will be applied unless new correction value is saved for the field of view. (See 3.4.9.)
- In the bi-directional scanning, [Bleach mode setting] and [Allow Rotation by mouse] are disabled. (See 3.7 and 3.4.8.1.)
- In the bi-directional scanning, available pixel number by steps is 256 or 512.

Single directional scanning:

- For the four-laser unit, a special function works automatically. With this function, the specimen is shielded from the laser light when moving the laser scanning point from the end point of a scan to the next start point. When the three-laser unit and AOM are connected, this shielding function can be turned on and off as desired. (See 5.2.1, "Lasers tab.")

Note: CLEM mode

When CLEM equipment is connected, another scan mode is added: "CLEM" mode. Select "CLEM" mode to scan using the CLEM equipment.

CLEM mode: CLEM scanning is possible under a lower than usual level of irradiation from excitation light, which enables image acquisition without as much fluorescence photobleaching of the sample. The dynamic range can be enlarged, and this mode helps prevent loss of image quality. (See 3.10.)

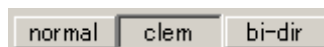

Name	Function Overview
[clem]	Scan in scan mode using CLEM equipment. The CLEM equipment can be used in data acquisition.

- ! CLEM functions cannot be used in spectral mode. They are enabled only in standard mode.
- ! CLEM functions cannot be used when the four-laser unit is connected. They are enabled only when the three-laser unit is connected.

3.4.7 Displaying the Scan Range

The currently set scan area is indicated by a rectangular parallelepiped (or a rectangle) inside the black rectangular parallelepiped in the Acquire Settings dialog box (see 3.4).

The yellow line indicates the currently scanned position. For XYZ scan, the yellow line moves from top to bottom along with the focal plane of the sample.



Note

- A scan area on the XY plane is set by the x and y coordinates (see 3.4.8.2) or from the Navigation window (see 3.4.8). The component of the scan area in the Z direction is set in Z-stack (see 3.5.5).
- To scan from bottom up in XYZ scanning, select the check box "Start Scan at Bottom" on the Z-Scan tab (see 5.1.3) of the Configure menu Z-drive RFA (or Microscope TE2000-E).

3.4.8 Navigation window

3.4.8.1 Specifying a Scanning Area (Navigation Window)

When you click the [Navigation] button located in the Acquire Settings dialog box (see 3.4), a Navigation window is displayed.

You can specify the position and size of a scanning area in the Navigation window and set the method for specifying those positions and sizes on the XY tab.

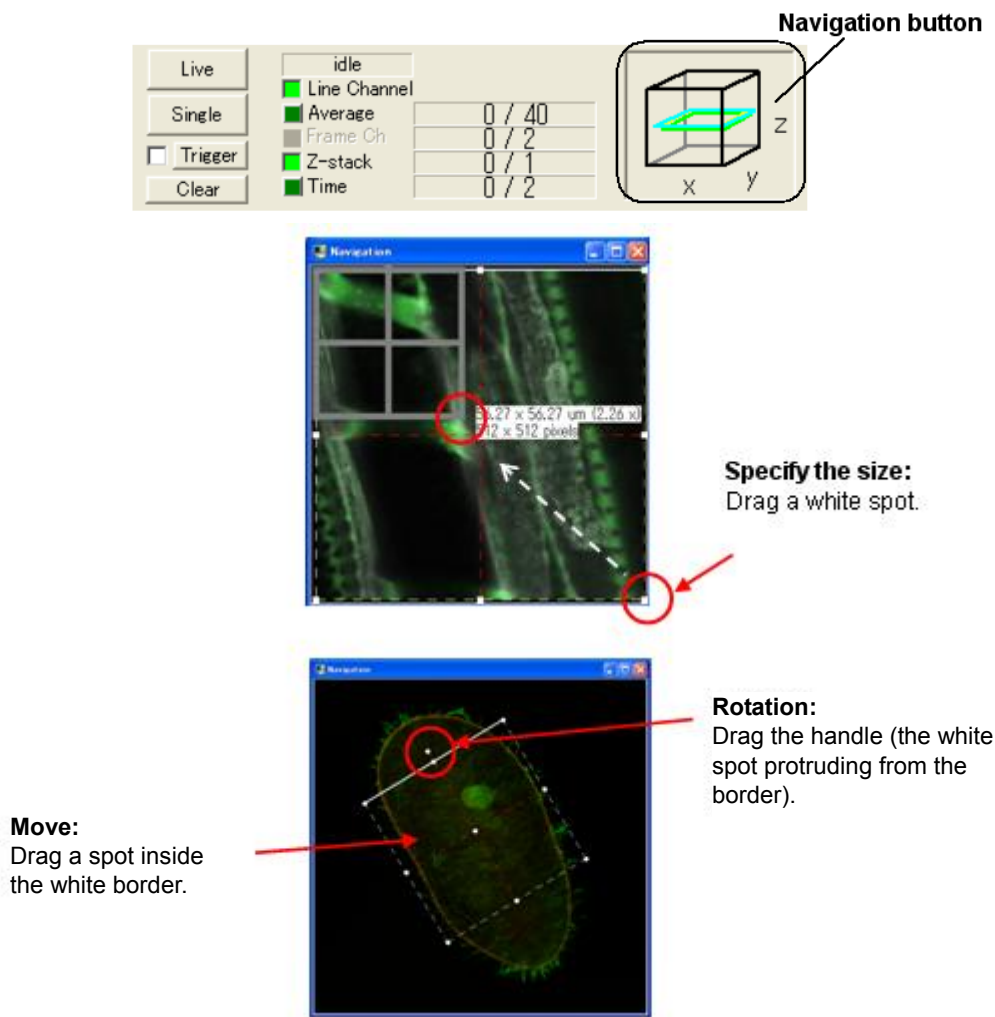

Figure 3.4-3 Navigation Window

Name	Function Overview
Specify the size	<p>The size of a scanning area can be specified by dragging a white spot on the white dotted line border in the image displayed in the Navigation window (see Figure 3.4-3). While you are dragging, the size of the actual scanning area (um), a ratio to the original image (x), and the size of the image (number of pixels) are displayed on the right side of the cursor.</p> <p>! Holding down the Shift key while dragging allows to zoom in or out with the center of the scanning area fixed.</p>

Move	A scanning area can be moved by holding and dragging a spot inside the white border (see Figure 3.4-3).
Rotate	<p>Select the option “Allow Rotation by mouse” (see 3.4.8.2) on the Navigation tab to specify that the scanning area will be rotated.</p> <p>Drag the handle (the white spot protruding from the border) to rotate the scanning area. Angle of rotation can be specified in the range of –90 degrees to 90 degrees with respect to the horizontal position that is defined to be 0 degrees.</p> <p>! Rotating the scanning area cannot be used during a reciprocal scanning (see 3.4.6.2).</p>

3.4.8.2 Specifying a Scanning Area (XY Tab)

Scanning area can be specified on the XY tab. (See Figure 3.4-4.)

Use the XY tab to make the following settings.

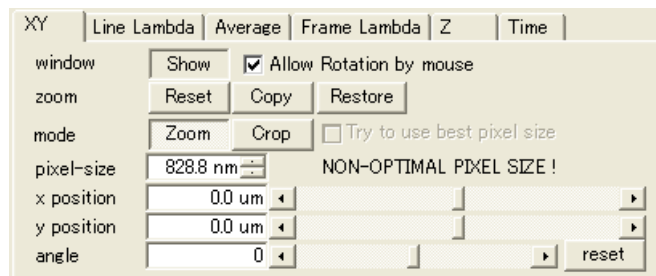
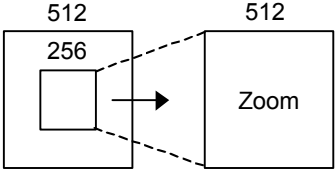
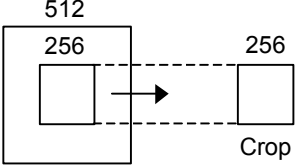





Figure 3.4-4 XY tab

Name	Function Overview
Window group	
[Show]	Display in the Navigation window appears or disappears by this button. This button functions the same as the [Navigation] button in the Acquire Settings dialog box.
Allow Rotation by mouse	To rotate the scanning area, check this check box. ! This function is disabled in the bi-directional scan mode.
Zoom group	
[Reset]	Press this button to reset all settings to the initial condition at the start-up of the Navigation window. The image on the Navigation window disappears.
[Copy]	Press this button to capture the image in the Live window to the Navigation window. The captured image is used as the reference to specify an area. ! If the scan settings are changed, this button is disabled until new image is captured using [Live] or [Single].
[Restore]	Press this button to specify the scanning area to the full image in the Navigation window.

Mode group	
Zoom	<p>The specified area is scanned with the number of pixels specified by steps in the Acquire Settings dialog box. The resolution increases.</p> 
Crop	<p>The specified area is scanned with the number of pixels existing in the specified area. Although the resolution does not increase, the scanning time is reduced.</p> 
Try to use best pixel size	<p>If you select this option, an optimum pixel size is set based on the wavelength of the laser and the N.A. of the objective. However, the software may not be able to set the optimum pixel size. In such cases, the message "WARNING: NON-OPTIMAL PIXEL-SIZE!" is displayed in white at the mouse position being dragged or in red below this option.</p>
pixel-size	Displays the size of 1 pixel. The size can be adjusted by entering a value.
x position	When the X position is increased, the scanning area moves in the positive direction of the X-axis. When the X position is decreased, the scanning area moves in the negative direction of the X-axis. It is also possible to specify the position on the Navigation window by clicking the zoom icon  with the mouse.
y position	When the Y position is increased, the scanning area moves in the positive direction of the Y-axis. When the Y position is decreased, the scanning area moves in the negative direction of the Y-axis. It is also possible to specify the position on the Navigation window by clicking the zoom icon  with the mouse.
angle	Specify the angle of the scanning area. The horizontal scanning angle is 0 degree. This value can be specified from -90 degree to 90 degree.  This option cannot be used for the bi-directional scanning.
[reset]	Resets the angle to zero.

3.4.9 Bi-Directional Scan bar

When you select Bi-Directional Scan from the Tools menu, a Bi-Directional Scan bar (Figure 3.4-5) is displayed. In this bar, you can switch between reciprocal scanning (see 3.4.6.2) and one-way scanning and correct a drift in images during reciprocal scanning.

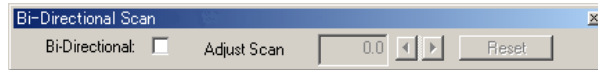

Figure 3.4-5 Bi-Directional Scan bar

The Bi-Directional Scan toolbar provides the following functions.

Name	Function Overview
Bi-Directional	Switches between reciprocal scanning (see 3.4.6.2) and one-way scanning. When you press the [Live] (or [Single]) button in Acquire Settings while this check box is selected, reciprocal scanning is performed.
Adjust Scan	Corrects a drift in the images scanned in the outgoing and return paths during the reciprocal scanning. Select the “Live” and change the value while monitoring the captured image to eliminate a drift.
[Reset]	Sets the Adjust Scan value (drift correction value in the current field of view) to 0.0.

Note



- You cannot use Adjust Scan and [Reset] unless Bi-Directional on the Bi-Directional Scan bar or bi-dir in Acquire Settings dialog box is selected.

3.4.10 Acquire bar

The Acquire bar contains shortcut buttons for the Acquire Settings dialog box (see 3.4.3). The Acquire bar is one of the dialog boxes (see 4.8) that can be displayed by checking the EZ-C1 “Acquire bar” command of the “Tools” menu. The Acquire bar contains the following buttons.















Name	Function Overview
	Show/hide Acquire Settings tool.
	Start/stop scanning.
	Increase Pixel dwell value (the acquisition speed is decreased).
	Decrease Pixel dwell value (the acquisition speed is increased).

	Displays the Navigation window (see 3.4.8).
	Specify the CTE marker (current time event marker), which is one of time event markers. This marker is used to set an event before or during an observation. Clicking this button displays a period of time from “the time at which a marker is set” to “the time at which frame data acquisition starts” for each frame. (Refer to “3.5.6 Time Series.”)

3.4.11 Acquire Position bar

The Acquire Position bar contains shortcut buttons for the Acquire Settings dialog box (see 3.4.3). The Acquire Position bar is one of the dialog boxes (see 4.8) that can be displayed by checking the EZ-C1 “Acquire Position bar” command of the “Tools” menu. The Acquire Position bar contains the following buttons



Name	Function Overview
	Decrease X-position; move left.
	Increase X-position; move right.
	Decrease Y-position; move backwards.
	Increase Y-position; move to the front.
	Increase field of view: zoom out.
	Decrease field of view: zoom in.
	Increase Z-position: move up: only with a Z-drive.
	Decrease Z-position: move down: only with a Z-drive.
	Increase Z-range: only with a Z-drive.
	Decrease Z-range: only with a Z-drive.
	Increase number of Z-steps: only with a Z-drive.
	Decrease number of Z-steps: only with a Z-drive.

3.4.12 Acquire Mode bar

If you wish to display the captured image over the entire screen, items displayed at the right-hand side (such as the Acquire Settings dialog box) can get in the way. In this case, you may choose not to display such items. When the Acquire Settings dialog box is not displayed, you can still select an image-capture mode from the Acquire Mode bar.

Each of the buttons is linked to the following check boxes. Note also that when you click on a given box, the corresponding check box is activated.



Figure 3.4-6 Acquire Mode Bar

Name	Function Overview
LT	Line scan check box
LC	Line Channel check box
A	Average check box
FC	Frame Channel check box
Z	Z-stack check box
T	Time check box

3.5 Acquire Settings (2: Image acquiring mode settings)

3.5.1 XY

Use the Navigation tab in the Acquire Settings dialog box to set the position and size of the scanning area. (See 3.4.8 “Navigation Window”.)

3.5.2 Line Lambda

CAUTION

- This function is not available in the spectral mode. Use this mode only in the standard mode.
- This function cannot be used when Bleach is performed.
- This feature is unavailable when the three-laser unit is connected.

To acquire images in line sequential scanning, enable the Line Channel checkbox (a checkbox for an image acquisition mode) in the Acquire Settings dialog box. In line sequential scanning, scanning is performed while switching the PASS settings for each line. A shutter and channel can be set for each PASS. The current value in the Gain bar is set for Gain.

Use image acquisition in line sequential scanning if cross talk between channels presents problems. In comparison with frame sequential scanning, line sequential scanning has the advantage of simultaneity in data between channels.

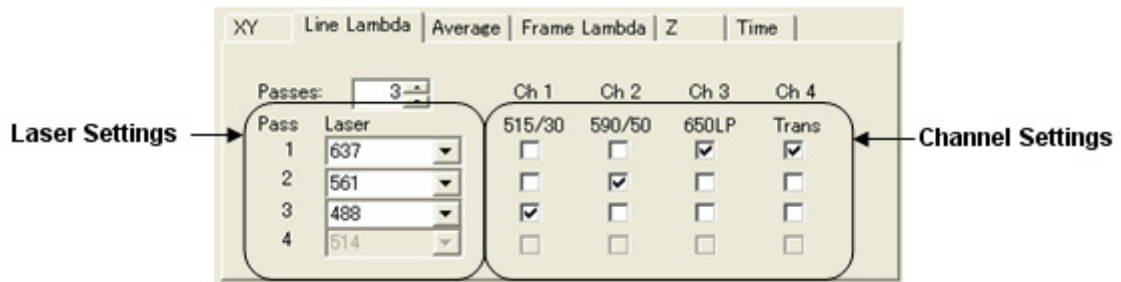





Figure 3.5-1 Line Lambda tab

Line Channel mode's image acquisition buttons allow you to perform the following tasks.

Name	Function Overview
	Live scanning is performed in line sequential scanning. Press the [Live] button once again to stop scanning.
	Single scanning is performed in line sequential scanning.

The actions and meaning of various buttons and parameters in the Line Lambda tab are shown below.

Name	Function Overview
Passes	Specify the PASS count.
Laser settings	Specify the laser for each PASS. The settings in the Laser and Detector dialog box can be used here. (Example: )
Channel settings	Specify the channel data for each PASS. Two or more channels can be used for one channel. The settings in the Laser and Detector dialog box can be used here. (Example: )

Note

- The settings in the Laser and Detector dialog box are linked to those on the Line Lambda tab. Lasers and detectors selected in the Laser and Detector dialog box are automatically set in respective fields in PASS on the Line Lambda tab “in descending order of laser wavelength.” PASS can be set and changed on the Line Lambda tab.
Ex.) When “Laser = 488, 543, 637” and “channel = 515/30, 590/50, 650LP” are set in the Laser and Detector dialog.
Pass1=637, 650LP, Pass2=543, 590/50, and Pass3=488, 515/30 are automatically set.

3.5.3 Average

To acquire averaged images, enable the Average checkbox (a checkbox for an image acquisition mode) in the Acquire Settings dialog box. You must specify real-time averaging parameters in the Average tab (Figure 3.5-2). Averaging has been made available as an addition following the assignment of weights to new and averaged images. This command provides improved signal-to-noise ratios for images, with no changes over time.

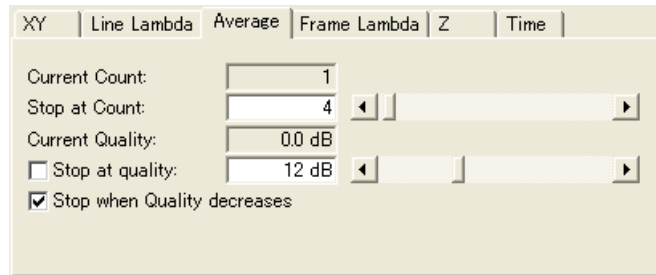





Figure 3.5-2 Average tab

Acquire Average mode's image acquisition buttons allow you to perform the following tasks.

Name	Function Overview
	Press this button to begin image acquisition and repeat averaging. Press the [Live] button once again to stop image acquisition.
	Press this button to start image acquisition. In this case, averaging will automatically stop according to the selected averaging option. Press the [Single] button once again to stop image acquisition.

The following averaging options are available on this tab.

Name	Function Overview
Current Count	The number of images acquired for the purpose of calculating the average
Stop at Count	Check this option to stop the averaging at the preset number of images.
Current Quality	The signal to noise ratio of the averaged image. The most optimal average image is obtained when the signal to noise ratio does not improve anymore.
Stop at quality	Check this option to stop the averaging at the preset quality.
Stop when Quality decreases	If you enable this option, averaging calculation stops if the image quality is found to be degraded compared to the value obtained from the previous averaging calculation, restoring the image to the highest quality.
Automatic Best Color Fit	Check this option to perform the "Best Intensity Fit" operation after each calculation. (Same operation is obtained when  button on the Color tab in the View Settings dialog box. See 3.6.2.)

Note

- At first, color mapping is optimized about the black picture anything does not have an image. Therefore, although the first Average calculation picture looks very bright, it is not failure of a machine.

3.5.4 Frame Lambda

CAUTION

- Pass settings cannot be completed on this tab in **spectral mode**. The settings are configured automatically from settings in the Laser and Detector Profile dialog box. (See 3.2.1 “Detector tab” (4) Sequential acquisition settings.)

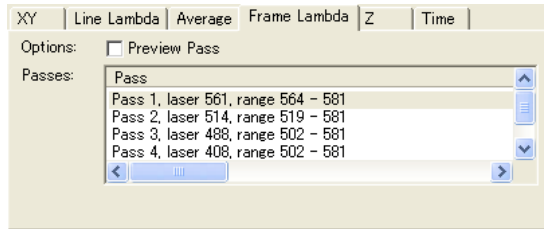

To acquire images in frame sequential scanning, enable the Frame Ch checkbox (a checkbox for an image acquisition mode) in the Acquire Settings dialog box. In frame sequential scanning, scanning is performed while switching the PASS settings for each frame. A shutter, channel, pinhole can be set for each PASS setting. Use image acquisition in frame sequential scan if crosstalk between channels presents problems.

“Pass” can be set in the Laser and Detector dialog box in the standard mode.

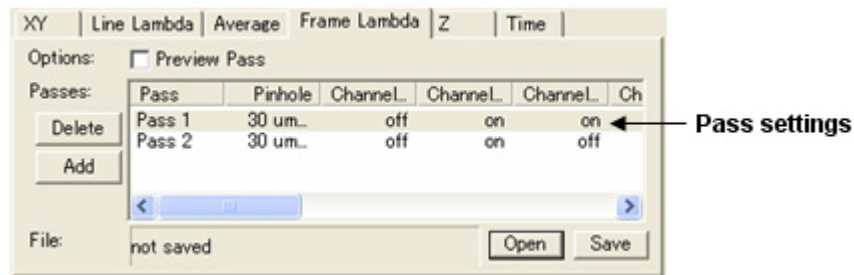

Figure 3.5-3 Frame Lambda tab

Acquire Frame Lambda mode’s image acquisition buttons allow you to perform the following tasks.

Name	Function Overview
Live	Live scanning is performed in frame sequential scanning. Press the [Live] button once again to stop scanning.
Single	Single scanning is performed in a frame sequential scanning.

The actions and meaning of various buttons and parameters in the Frame Lambda tab are shown below.













Name	Function Overview
Preview Pass	Acquires images for a single PASS that has been selected.
[Delete]	Deletes the selected PASS.
[Add]	Adds a new PASS.
File	Displays the saved filename.

[Open]	“Passes” settings can be saved in files with extension *.ech. Press this button to open a dialog box for selecting one of these files so that settings can be loaded.
[Save]	Saves “Passes” settings in a file.

Path settings

“PASS” can be set in the Laser and Detector dialog box.

The actions and meaning of various buttons and parameters in the Frame Lambda tab are shown below.

Name	Function Overview
Channel 1 to 4	Specifies the channel assigned to the PASS. Multiple selections are possible. Parameter values are changed using the buttons Detector     on the “Laser and Detector” tool bar while a PASS has been selected.
Pinhole	Specifies the size of the pinhole in each PASS. Parameter values are changed using the  button on the “Laser and Detector” tool bar while a PASS has been selected.
Shutter1 to 3	Specifies whether the laser shutter is opened or closed for each PASS. Parameter values are changed using the buttons Laser        on the “Laser and Detector” tool bar while a PASS has been selected.
Gain 1 to 4	Specifies the gain value for each PASS. Parameter values are changed by manipulating the “Gain” bar values while a PASS has been selected.

3.5.5 Z-stack

To acquire 3D images (X, Y, and Z), enable the Z-stack checkbox (a checkbox for an image acquisition mode) in the Acquire Settings dialog box. In this case, you can specify Z-axis drive parameters on the Z-stack tab (Figure 3.5-4). This control field is available only if the Z-axis drive unit is installed.

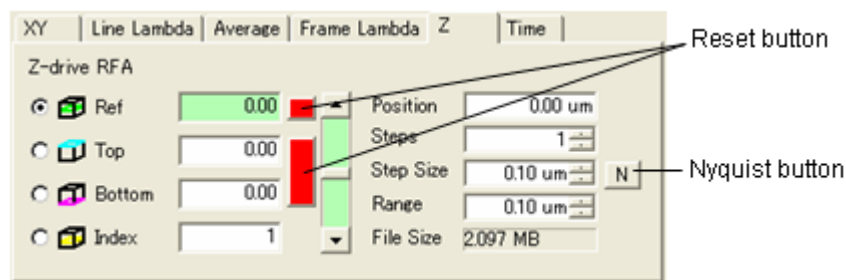



Figure 3.5-4 Z-stack tab

CAUTION
 When the Nikon perfect focus system for the TE2000-E is used with the system, the Z-stack settings have limitations. (For details about the perfect focus system, refer to the TE2000 PERFECT FOCUS SYSTEM instruction manual.)
 - The offset value of the perfect focus system cannot be moved with the Z-axis driving.

Acquire Z-stack mode's image acquisition buttons allow you to perform the following tasks.

Name	Function Overview
	Press this button to acquire images from uppermost to lowermost slices according to the settings for the parameter listed below. When image acquisition at the lowermost slice is complete, image acquisition restarts from the uppermost slice. Press the [Live] button once again to stop image acquisition.
	Press this button to acquire images from uppermost to lowermost slices according to the parameter settings. Unlike Live, image acquisition stops when the lowermost slice is reached. Press the [Single] button to stop image acquisition.

Note

<Z-Stack mode with the perfect focus system>

- Start an image capturing with the status of the [PFS] button is shown as . (An offset value is specified.) Move the Z position to the reference position. Focus on the reference position. And then, capture an image while the focusing control is running.

The actions and meaning of various buttons and parameters in the Z-tab are shown below.

Name	Function Overview
Ref (Reference)	Check this option and move slider bar to move the position of whole scanning area. You can move the position by using the knob on the Z-drive device. When the perfect focus system is used, the focusing control is performed so that the reference position is the focus position.
Top	Check this option to move the scanning position to the top of scanning area. Move the slider with this option is checked to change the top position of the scanning area. In this time, the scanning volume is defined again with new top position and original bottom position. You can move the position by using the knob on the Z-drive device.
Bottom	Check this option to move the scanning position to the bottom of scanning area. Move the slider with this option is checked to change the bottom position of the scanning area. In this time, the scanning volume is defined again with original top position and new bottom position. You can move the position by using the knob on the Z-drive device.
Index	The number of the currently displayed scanning image. The first scanning plane is "1".
Reset button	Press the upper one to restore Reference value to its initial setting. Press the bottom one to restore Top, Bottom and Index values to their initial settings. - Do not use the reset button on the controller. This will cause it unable to measure Z position in the application. If you use it by mistake, press the bottom reset button on this window to reset settings.

Position	The physical position in the Z direction. This is the relative distance from the position where Z-drive is started.
Steps	Set the number of steps to be scanned.
Step Size	Set the physical distance between steps.
Nyquist	Sets the optimum value for the step size based on the resolution of the objective as specified by the "Objective" command on the "Configure" menu.
Range	Specifies the scanning range in the Z-direction.
File Size	Displays the file size of acquired image based on the above parameter settings.
Scroll bar	This bar is used to operate the Z-drive and move the Z position of the Z-axis. When the perfect focus system is used, adjust the offset value of the perfect focus system.

3.5.6 Time Series

To acquire images in time series mode, enable the Time check box (a checkbox for image acquisition mode) in the Acquire Settings dialog box. Click the Time Series tab to set parameters (Figure 3.5-5). Displays a Time Series window, showing images acquired at specific points in time. Image data from 1D to 3D can be acquired at each specific point in time depending on the mode selected in the Acquire Settings dialog box.

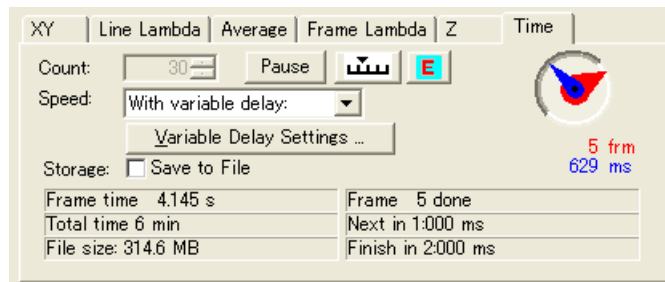

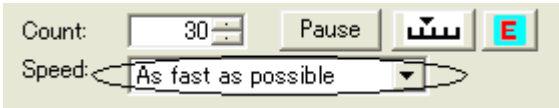
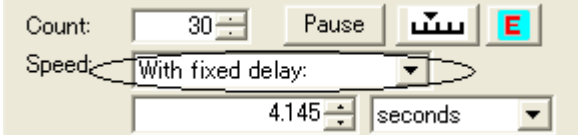
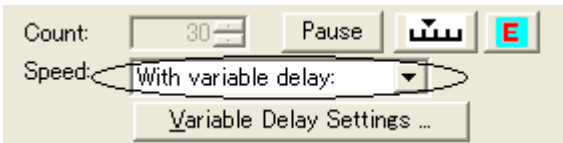

Figure 3.5-5 Time Series tab







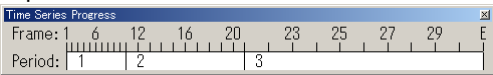

Acquire Time Series mode's image acquisition buttons allow you to perform the following tasks.

Name	Function Overview
	Press this button to start time series image acquisition. Press the [Live] button once again to stop image acquisition.
	Press this button to acquire images in a single time series sequence. Press the [Single] button to stop image acquisition.

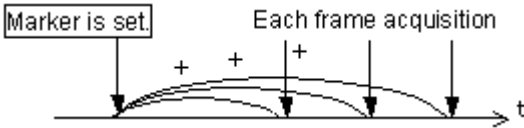
The Time Series options on this tab are shown below.

Name	Function Overview
Count	The number of frames acquired.
Speed	

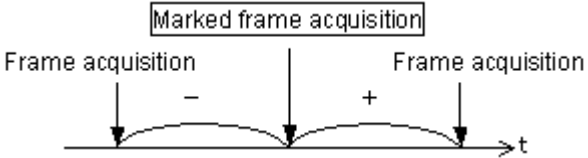
<p>As fast as possible</p>	<p>Images are acquired in succession with no intervening delays when multiple frames need to be obtained.</p> 
<p>With fixed delay</p>	<p>Multiple frames are acquired at fixed intervals. Set an interval between the time at which frame scan starts and the time at which the next frame scan starts.</p> 
<p>With variable delay</p>	<p>Multiple frames are acquired at variable intervals. Creates a sequence. (See 3.5.6.1 "Variable Delay Settings".)</p> 
<p>Press Next Button</p>	<p>During scanning of each frame, the [Next] button functions like a trigger to start scanning.</p>  <p>! If Time Series settings are changed when operation is paused, observations are halted and resumed from the beginning.</p>
<p>Storage</p>	
<p>Save to File</p>	<p>Select this check box to save each image to a file at the time it is acquired. - If you do not select this check box, use Save or Save As on the File menu to save each image to a file after the sequence has finished.</p>
<p>[Pause]</p>	<p>Pauses observation during Time Series observation (under settings of As fast as possible, With fixed delay, or With variable delay). ! If Time Series settings are changed when operation is paused, observations are halted and resumed from the beginning.</p>
	<p>Shows time schedules for the currently set image acquisition with a progress bar. During image acquisition, the yellow arrow moves to indicate the current status of image acquisition.</p> 

<p> Event marker (CTE)</p>	<p>Specify the CTE marker (current time event marker), which is one of time event markers. This marker is used to set an event before or during an observation. Clicking this button displays a period of time from “the time at which a marker is set” to “the time at which frame data acquisition starts” for each frame.</p>  <p>(Time displayed = “the time at which frame data acquisition starts” - “the time at which a marker is set”)</p>  <ul style="list-style-type: none">  The shortcut button that functions in a same manner is provided on the Acquire bar.  An ATE marker  (acquisition time event marker) is provided on the Annotate bar. This marker targets only the Time Series data after the observation and is used to set an event in the acquired data. Clicking this button displays a difference from the time at which frame data acquisition starts” for each frame based on “the time, for which a marker is set, at which frame data acquisition starts.  <p>(Time displayed = “the time at which frame data acquisition starts” - “the time, for which a marker is set, at which frame data acquisition starts”)</p> 
<p>[Status] The status field contains current information that is updated during acquisition and when the settings are changed. The field may contain the following items.</p>	
<p>Frame time</p>	<p>The minimal acquisition time for one frame. Note that for some devices, the actual acquisition time will be longer due to starting and stopping procedures.</p>
<p>Total time</p>	<p>An estimated total acquisition time for the entire series. (If Z-stack and Time Series modes are both selected, the time displayed is total acquisition time.)</p> <ul style="list-style-type: none">  These values should be considered as only a rough guideline since the time it takes to acquire the data depends on CPU and network loads.
<p>File size</p>	<p>The size of the time-series image file. (Shows total file size if Z-stack and Time Series modes are both selected.)</p>

Frame	The index of the frame last acquired. The red large hand of the dial clock also shows this number.
Next in	The time period after which the next frame will be acquired. The blue small hand of the dial clock also shows this number.
Finish in	The time period after which the time series will be completed.

Note

<Saving images during execution of Time Series>
 Images composed of the number of acquired frame data are saved.

3.5.6.1 Variable Delay settings

Select “With variable delay” for Speed in the Time Series tab, then press [Variable Delay Settings] to display the Variable Delay Settings dialog box (Figure 3.5-6). Set a time series sequence with different interval times in this dialog box.

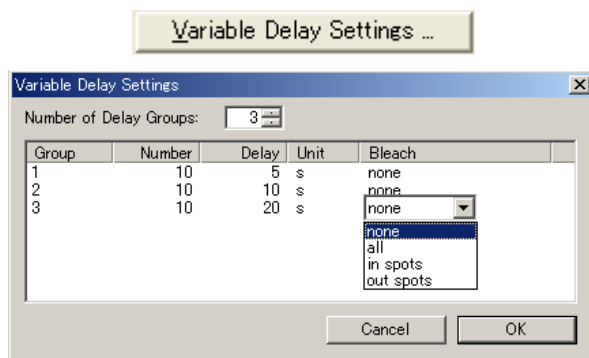

Figure 3.5-6 Variable Delay Settings dialog box

Name	Function Overview
Group	Step number
Number	Number of acquired frames
Delay	Frame acquisition interval
Unit	Unit of delay time (ms, s, min, or hr)
Bleach	Sets bleach for each step.
none	No bleaching is performed.
all	The entire scan area is bleached.
in spots	The area inside the target spots is bleached.
out spots	The area outside the target spots is bleached.

Note

<Image display while performing the Bleach step as a part of a sequence>

- EZ-C1 actively switches off the gain voltage supply when incidence laser intensity significantly increases.

When performing the bleach step as part of a sequence, check “Block Detectors during Bleaching” on the Bleach tab in the Configure Confocal C1 dialog box to automatically set the gain to “0” to prevent a loss of the gain voltage. The image is not displayed during bleaching.

3.6 View settings

Set the method for displaying an image window in the View Settings dialog box. Choose View Settings from the EZ-C1 Tools menu or press  in the View bar (see 3.6.4) to display this dialog box. The View Settings dialog box has the following tabs.

- **Info:** Shows information related to images. (See 3.6.1)
- **Color:** Use this tab to set channel display. (See 3.6.2)
- **View:** Use this tab to set display mode. (See 3.6.3)

3.6.1 Info tab

The View Settings | Info tab (Figure 3.6-1) shows information on currently active windows.

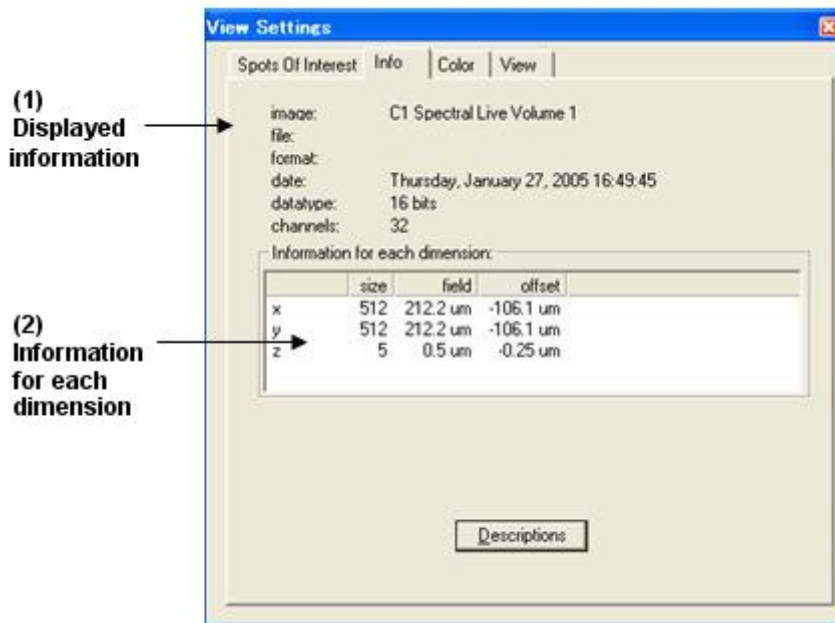
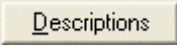





Figure 3.6-1 Info tab in the View Settings dialog box

(1) Displayed Information

This function shows information on active images.

Name	Function Overview
image	The name of the image.
file	The file name of the image. The file name is not shown when the image is not saved.
format	The default file format.
date	Date of data acquisition.
datatype	The number of bits of a pixel brightness value.
channels	The number of channels in the image.
 [Descriptions]	<p>This button opens the Description dialog box used for entering comments on images.</p> <p> This dialog box can also be opened with the File menu Description command or View bar  button.</p> <p> Comments are saved with images in the ids or Tiff format, but not with other image formats. (See 4.1.9)</p>

(2) Information for each dimension

This function shows the physical size of each dimension.

Name	Function Overview
size	The number of pixel.
field	A value that indicates image size in physical units.
offset	The origin (top left corner for a 2-dimensional image) of the image pixel coordinate system expressed in visual field coordinates.

3.6.2 Color Tab

Use the View Settings | Color tab to set the channel display in the currently active image window. Assign channel color, turn channel display on/off, set the upper and lower brightness limits and make other settings.

- In the spectral mode, this tab provides the following three color modes:
 - (1) Multi Channel Pseudo Color Assigns pseudo colors to each channel data and uses multiple channel data to display images.
It also groups channels in specific ranges and assigns colors to groups in images acquired in the spectral mode.
 - (2) Single Channel LUT Assigns pseudo colors to one channel data and displays such channel data images.

- (3) Multi Channel True Color Displays images for all channels in the wavelength color corresponding to the wavelength range when data is acquired. These colors are close approximations to those seen by the naked eye.

3.6.2.1 Multi Channel Pseudo Color Mode

When Images Acquired by the Spectral Detector are Active

Use this mode to assign a color from the pseudo color palette to each data channel and to adjust the multi channel data for display images.

You may also group channels in a specific range and assign a color to each group.

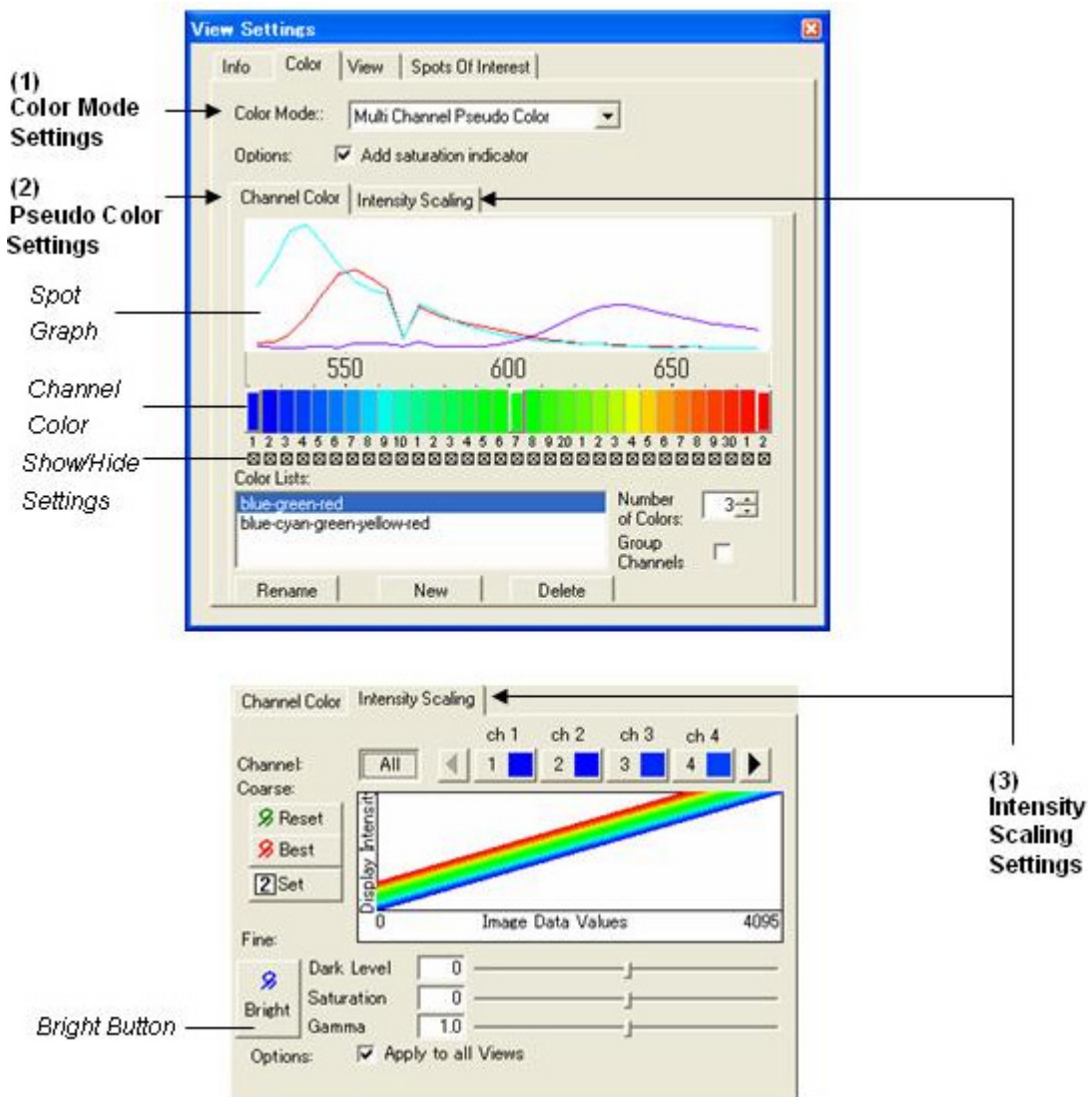

(1) Color Mode Settings

(2) Pseudo Color Settings

Spot Graph

Channel Color

Show/Hide Settings

(3) Intensity Scaling Settings

Bright Button

(1) Color Mode Settings

Use this function to set a color mode.

Name	Function Overview
Color Mode	Select the following mode from the three color modes. (1) Multi Channel Pseudo Color mode
Add saturation indicator	Set a saturation indicator. Pixels in the image with brightness values exceeding the Saturation Level of any channel are displayed in a color complementary to that of the channel.
Add black level indicator	Specify whether or not a pixel with no brightness value is displayed in white. A pixel with no brightness value in each channel image is displayed in white.



(2) Pseudo Color Settings

Use this function to assign channel colors and show and hide settings.

Name	Function Overview
Spot Graph indication	Show a spectral graph for a spot in a currently active image. The vertical axis indicates Intensity and the horizontal axis indicates wavelength.
Channel Color	Display the currently selected color for any channel. Click on a channel used as a button (standard color button) to use a color palette to set colors. (A detailed description of standard color buttons is given in the Section, "Number of Colors".)
<input checked="" type="checkbox"/> / <input type="checkbox"/> Show/Hide Setting	Show or hide data for a channel.
Color Lists	Show lists of color settings. <ul style="list-style-type: none"> - When the C1 Spectral Live window is active, the following color settings are displayed by default. <ul style="list-style-type: none"> - blue-green-red : Displays colors for all channels using color interpolation based on blue, green and red. - blue-cyan-green-yellow-red : Displays colors for all channels using color interpolation based on blue, cyan, green, yellow and red. - When a saved image is active, the following color settings are displayed by default. <ul style="list-style-type: none"> - Pseudo Color : Displays the colors from the last save. <p>! Use the [New] button to generate a new color list to set colors other than the default colors given above.</p>

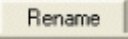

Note
 <For making user color settings>

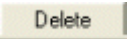



- (1) Press the [New] button to create a new color list.
- (2) Use Number of Colors when a new list is selected to determine the number of colors (the number of standard color buttons) to be set.
- (3) Click each standard color button to set colors.
- (4) Set Group Channels to OFF to show channels between color buttons using color interpolation. Set Group Channels to ON to set and display colors for specific areas.

 [Rename]	Changes the name of a selected color setting.
 [New]	Creates new color settings.
 [Delete]	Deletes selected color settings.
Number of Colors	Specify the number of colors to be used as a standard for setting colors. Color buttons for the specified number of colors are displayed. <ul style="list-style-type: none"> - Click a Standard Colors Button to open a color palette for setting colors. - When Group Channels is set to OFF, the channels between standard color buttons are displayed using color interpolation. - When Group Channels is ON, the area is divided by the number of channels. The channel of each area appears in the same color.
Group Channels	A number determined by the Number of Colors that divide areas and are used for setting area colors. <ul style="list-style-type: none"> - When ON, the dividers (black line) between groups can be grabbed by mouse to expand or contract an area. - When OFF, the channels between color buttons are displayed using color interpolation. <p>! In Intensity Scaling setting, adjustment is made using the group set in this section.</p>

(3) Intensity Scaling Settings

Use these functions to adjust color brightness.

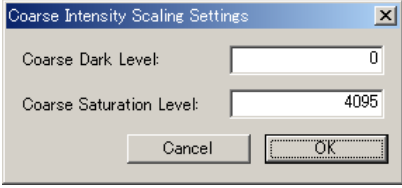
Name	Function Overview
 Channel	Selects the channel whose Dark Level, Saturation or Gamma you want to adjust. Use the right and left arrow keys to select a channel.
 [All]	Adjusts the Dark Level, Saturation or Gamma for all channels. Adjustments are made relative to the values set for each channel.
 [Reset]	Returns all Intensity Scaling settings to their default values. (Image Data Values, Dark Level, Saturation and Gamma are returned to 4095, 0, 0 and 1.0, respectively)

 Best [Best]	<p>A function that works with “standard data.” Automatically sets a range of brightness values to which colors are to be assigned. The highest brightness data of an active image constitutes the upper limit of brightness used in assigning colors.</p> <p>! Sets the upper limit for all slices of 3D and 4D data.</p>
 Set [Set]	<p>Sets a range of brightness levels to which colors are to be assigned based on the numbers a user enters in the text boxes below.</p>  <p>Coarse Dark Level: Sets the lower-limit value. Coarse Saturation Level: Sets the upper-limit value.</p>
 Bright [Bright]	<p>This function works with “spectral data.” It automatically sets the range of brightness levels to which colors are to be assigned. Sets 0.05% of the pixels in the brightest area of an active image (2D) to the upper limit (0.05% can be assumed to be noise).</p> <p>! Determines the upper limit for currently displayed slice images of 3D and 4D data and sets this level for all slices. To change the level for a currently displayed slice, press the [Bright] button again.</p>
<p>Dark Level</p>	<p>Sets the lower-limit value (dark level) of brightness for input data. The dark level is adjusted in the range from –100 to +100 with a baseline set to 0. Contrast is reduced for negative values and data is clipped for positive values.</p>
<p>Saturation</p>	<p>Sets the upper-limit value (saturation level) for input data. Saturation is adjusted in the range from –100 to +100 with a baseline set to 0. Contrast is reduced for positive values and data is clipped for negative values.</p>
<p>Gamma</p>	<p>Changes the γ curve for input data. Increasing the γ value brightens the image throwing its dark areas into relief.</p>
 Apply to all Views	<p>The Intensity Scaling setting is applied to all images linked to the active image.</p>

When Images Acquired by the Standard Detector are Active

Use this dialog box to assign pseudo colors to channel data and use multiple channel data to display images.

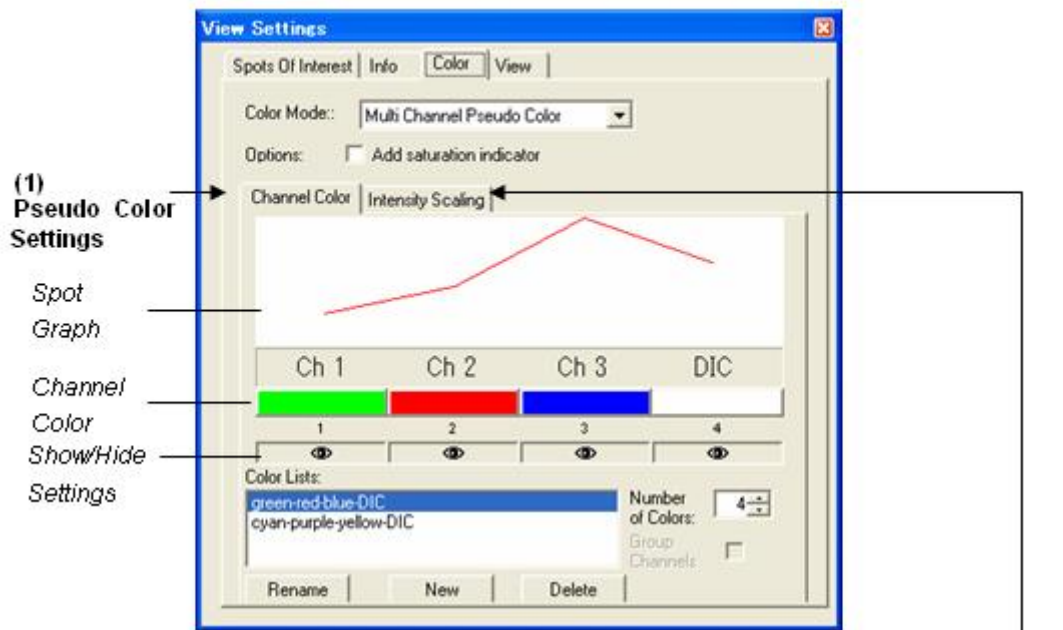
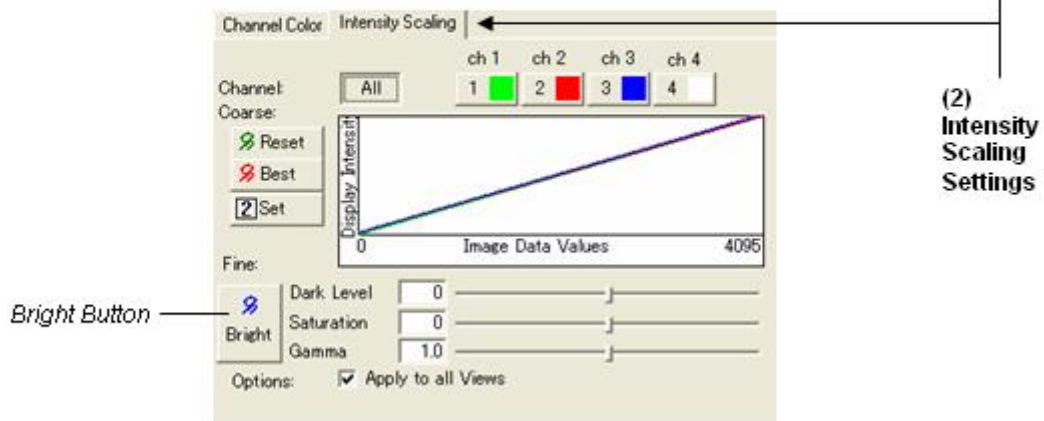



Figure 3.6-2 Color tab in the View Settings dialog box



(1) Pseudo Color Settings

Use this function to assign colors to channels and show and hide settings.



Name	Function Overview
Spot Graph Indication	Show a spectral graph for a spot in an active image. The vertical axis indicates Intensity and the horizontal axis indicates wavelength. The horizontal axis for active images acquired by the standard detector becomes the channel axis. ! PMT output data for each channel is specified on the Standard Detector tab of the Confocal C1 dialog box in the Configure menu.
Channel Color	– Functions the same way as when an image acquired by the spectral detector is active. –

 Show/Hide Settings	– Functions the same way as when an image acquired by the spectral detector is active. –
Color Lists	Show lists of color settings. - When the C1 Live window is active, the following colors are set by default. - green-red-blue-DIC : Use these settings to set the default color of PMT output data set in Configure Confocal C1 Standard Detector tab. Use the above tab to change settings, if required. - cyan-purple-yellow-DIC : Sets cyan, purple, yellow and white for 4-channel data. - When a saved image is active, the following colors are set by default. - Pseudo Color : Displays the colors from the last save.  Use the [New] button to generate a new color list to set colors other than the default colors given above.

Note

<For making user color settings>

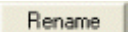
- (1) Press the [New] button to create a new color list.
- (2) Use Number of Colors when a new list is selected to determine the number of colors (the number of standard color buttons) to be set.
- (3) Click a standard color button to set a color.

 [Rename]	– Functions the same way as when an image acquired by the spectral detector is active. –
 [New]	– Functions the same way as when an image acquired by the spectral detector is active. –
 [Delete]	– Functions the same way as when an image acquired by the spectral detector is active. –
Number of Colors	– Functions the same way as when an image acquired by the spectral detector is active. –
Group Channels	– Functions the same way as when an image acquired by the spectral detector is active. –

(2) Intensity Scaling Settings

Use these functions to adjust color brightness.

A detailed description is given in “(3) Intensity Scaling Setting” under “When an Image Acquired by the Spectral Detector is Active” in Section 3.6.2.1, “Multi Channel Pseudo Color Mode.”

3.6.2.2 Color Select Dialog Box

Press a standard color button in the Multi Channel Pseudo Color mode to open the dialog box shown below. Use the color palette and wavelength data to set the desired colors.

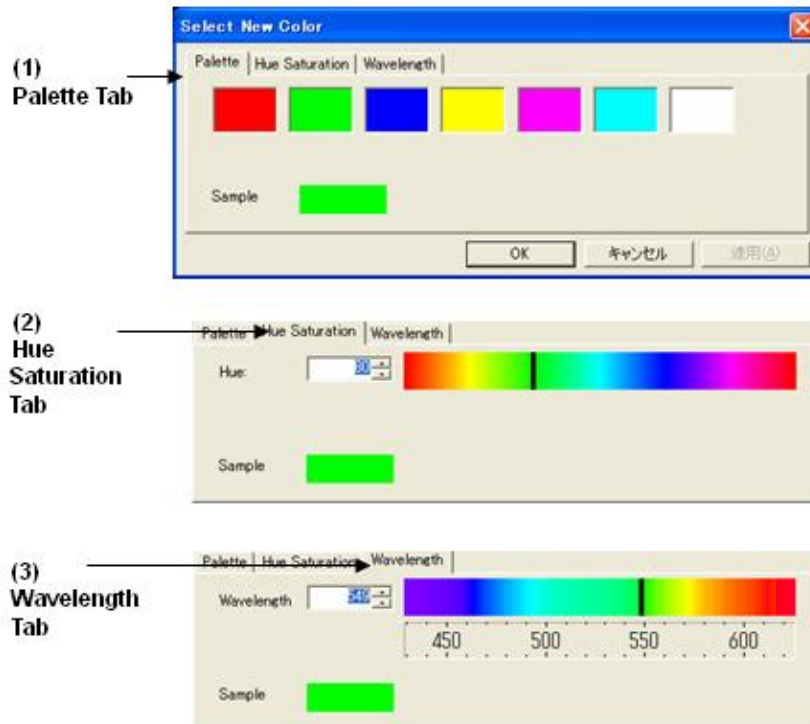

(1) Palette Tab

Select colors from the color palette.

Name	Function Overview
Color Palette	Select colors from red, green, blue, yellow, purple, cyan and white. Yellow, purple and cyan are for partial color blindness.
Sample	Displays currently selected colors.

(2) Hue Saturation Tab

Use this tab to set colors by selecting hues.

Name	Function Overview
Hue	Sets a hue. Between 0 to 240 hue gradations can be set.
Sample	Displays currently selected colors.

(3) Wavelength/Dye Tab

Select a color from a wavelength.

Name	Function Overview
Wavelength	Set a color based on wavelength. Enter a numeric value for the wavelength or use the rod to select a wavelength.
Sample	Displays currently selected colors.

3.6.2.3 Single Channel LUT Display Mode

Use this mode to assign pseudo colors to a channel data item and display that data item.

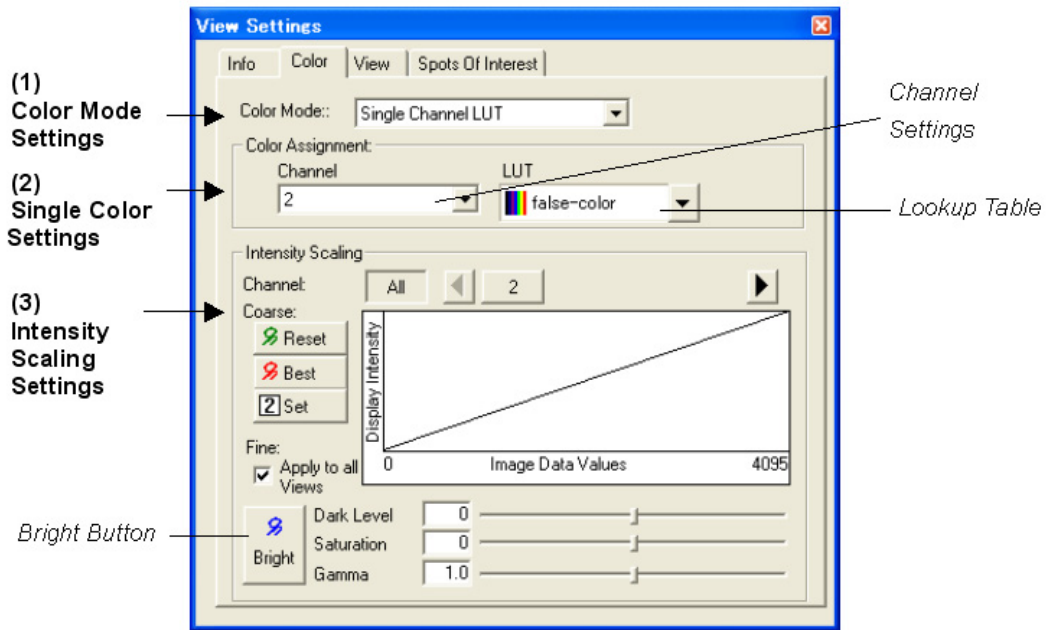

(1) Color Mode Settings

Use this mode to set the color mode.

Name	Function Overview
Color Mode	Select the following mode from the three color modes. (2) Single Channel LUT mode

(2) Single Color Settings

Use this setting to select channels and assign pseudo colors.

Name	Function Overview
Channel Setting	Select a channel to display images.
Lookup Table	Specify a lookup table for the selected channel. The following tables are available. - Gray-scale: A gray-scale table in which the monochrome tones from the darkest black to the brightest white is represented by 256 shades of gray. - False-color: Tones ranging from the darkest black to the brightest white are represented by blue, green, yellow, orange, red, purple, etc. The following lookup tables are also provided. - Rainbow - Rainbow Contrast - Iron - Green Fire - Green Fire Blue - Red Fire - Red Hot - Magenta Hot - Brown - Lemon Hot - Yellow Pale - Blue Red - Black Blue Red White - RCM8000

(3) Intensity Scaling Setting

Use these functions to adjust color brightness.

A detailed description is given in “(3) Intensity Scaling Settings” under “When Images Acquired by the Spectral Detector are Active” in Section 3.6.2.1, “Multi Channel Pseudo Color Mode”.

3.6.2.4 Multi Channel True Color Mode

Use this mode to display images for all channels in the wavelength color corresponding to the wavelength range when data is acquired. These colors are close approximations of those seen by the naked eye.

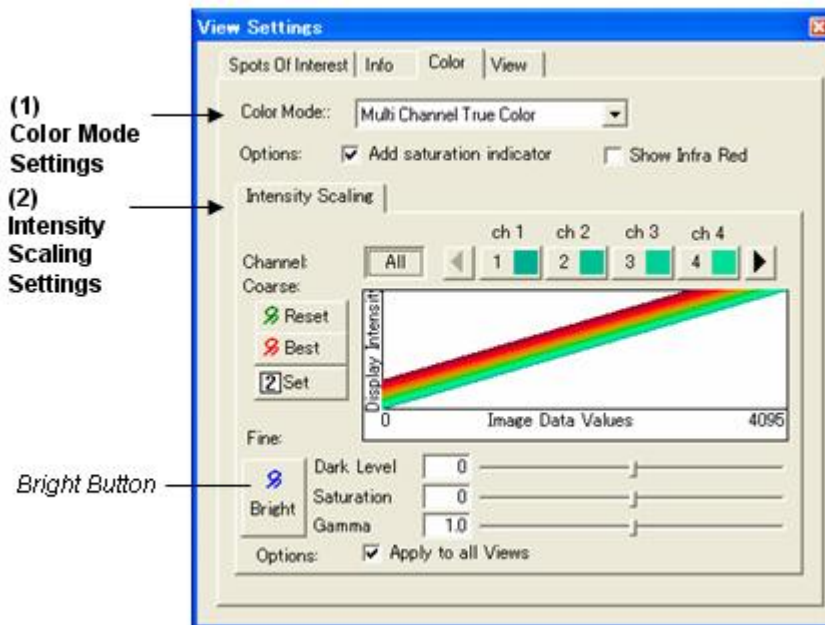

(1) Color Mode Setting

Use this function to set a color mode.

Name	Function Overview
Color Mode	Select the following mode from the three color modes. (3) Multi Channel True Color Mode
Add saturation indicator	Indicate the saturation level. Pixels in the image with brightness values exceeding the Saturation Level of any channel are displayed in a color complementary to that of the channel.
Show Infra red	Select a wavelength color to display infrared light that is otherwise not visible to the naked eye. - When ON, the wavelength color of the infrared area is brightly displayed. - When OFF, the infrared wavelength is displayed in a color that is visible to the naked eye.
Add black level indicator	Specify whether or not a pixel with no brightness value is displayed in white. A pixel with no brightness value in each channel image is displayed in white.

(2) Intensity Scaling Setting

Use these functions to adjust color brightness.

A detailed description is given in “(3) Intensity Scaling Settings” under “When Images Acquired by the Spectral Detector are Active” in Section 3.6.2.1, “Multi Channel Pseudo Color Mode”.

3.6.3 View Tab

Use the View Settings | View tab (Figure 3.6-3) to set display modes for currently active image windows.

- This tab provides the following five View modes.

For Image window

- | | |
|----------------------|--|
| (1) 1D graph | shows an intensity graph for currently set axis and position. |
| (2) 2D image | shows data for the currently selected axis plane. |
| (3) 3D orthogonal | shows the three orthogonal sections of 3D data. |
| (4) 3D tiled | shows image planes for 3D data or data with more dimensions in tile fashion. |
| (5) 2D channel tiled | shows channel images for 2D data or data with more dimensions in tile fashion. |

For Spot data t/z axis graph window

- | | |
|----------------|---|
| (1) Multi Line | shows an intensity graph for currently set axis and position. |
|----------------|---|

3.6.3.1 1D graph Mode

Use this mode to display an intensity graph for currently set axis and position.

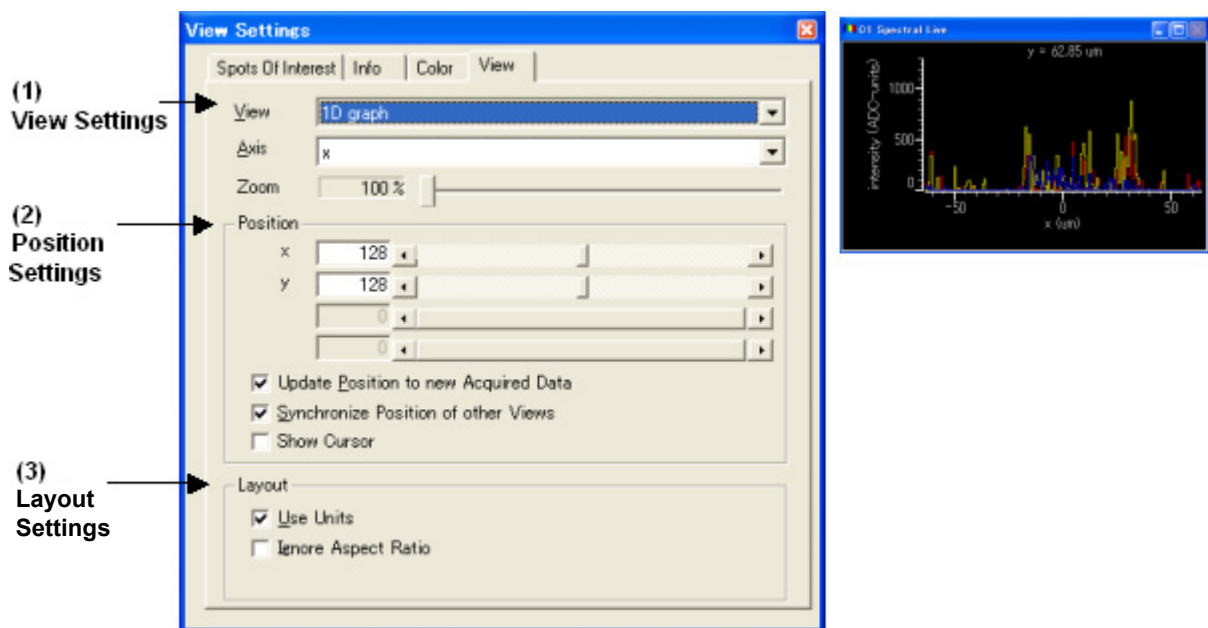

Figure 3.6-3 The View tab of the View Settings dialog box

(1) View Settings

Use these functions to set the View mode.

Name	Function Overview
View	Select the following View mode. (1) 1D Graph mode
Axis	Set the horizontal axis (line) for the intensity graph to be displayed. Select x, y, z and t. (z and t are used only for data with 3 or more dimensions.)
Zoom	Zooms the currently set axis.

(2) Position Settings

Use these functions to set positions.

Name	Function Overview
x, y, z, t	Use x, y, z and t to specify dimensional locations. (z and t are used only for data with 3 or more dimensions.) - When placed on the axis, the zoom operates using the axis as the center point.
Update Position to new Acquired Data	Select this checkbox to display the most recent view of the acquired image. When this option is not selected, the window will show the image according to position slider and cursor settings at all times making it possible to trace image changes manually.
Synchronize Position of other Views	When this checkbox is selected, the position settings of other views of the same image are synchronized. Deselect this checkbox to enable different positions of other views of the same image.
Show Cursor	Select this checkbox to display the cursor at all times. Deselect this checkbox to show the cursor only when the screen is clicked.

(3) Layout Settings

Use these functions to calculate indicator unit and window size adjustments.

Name	Function Overview
Use Units	Select this checkbox to display labels and axes in physical units and not in pixel units.
Ignore Aspect Ratio	By default, the width of an image expands to meet the horizontal and vertical ratio of the "field" value (see 3.6.1) on the View Settings Info tab. Select this checkbox to ignore "field" data and display images without horizontal expansion. When only this option is selected and the Layout option is also on, the image expands to fill the entire window area.

3.6.3.2 2D image Mode

Use this mode to display currently set axis plane data.

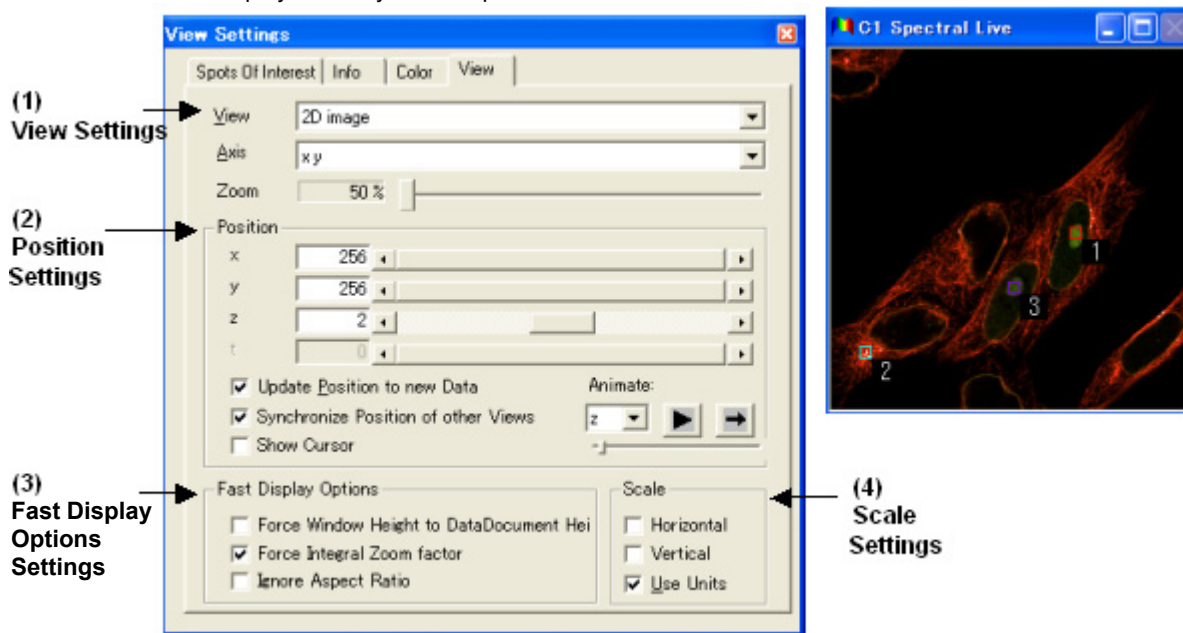

(1) View Settings







Use these functions to make View mode settings.

Name	Function Overview
View	Select the following View mode. (2) 2D image mode
Axis	Select a surface to display a 2D image. Select using xy, yx, etc. (z and t are used only for data with 3 or more dimensions.)
Zoom	Zooming is performed with the position location on the currently set axis held in the center.

(2) Position Settings

Use these functions to set positions.

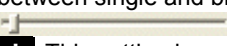
Name	Function Overview
x, y, z, t	Use x, y, z and t to specify dimensional locations. (z and t are used only for data with 3 or more dimensions.) - When placed on the axis, the zoom operates using the axis as the center point.

Update Position to new Data	Select this checkbox to display the most recent view of the acquired image. When this option is not selected, the window will show the image according to position slider and cursor settings at all times making it possible to trace image changes manually.
Synchronize Position of other Views	When this checkbox is selected, the position settings of other views of the same image are synchronized. Deselect this checkbox to enable different positions of other views of the same image.
Show Cursor	Select this checkbox to display the cursor at all times. Deselect this checkbox to show the cursor only when the screen is clicked.
Animate	<p>Animated displays are possible for data with three or more dimensions.</p> <p> Select an axis for an animated display.</p> <p> /  Starts and animated display. This button changes to a Stop button once the animated display starts.</p> <p> /  Sets the direction of an animated display. This button toggles between single and bi-directional display.</p> <p> Adjusts the speed of an animated display (slow – fast)</p> <p> This setting is available only for data with three or more dimensions.</p>

(3) Fast Display Options Settings

Use these functions to set calculations performed when window size is adjusted. When the Force Window Height to DataDocument Height option is selected, the image is displayed in a 1:1 scale that does not require any calculation and speeds up image display.

Name	Function Overview
Force Window Height to DataDocument Height	This option locks the window size to the same number of lines and pixels. Deselect this option to enable image resizing by dragging the image frame.
Force Integral Zoom factor	This option zooms in images in integral multiples and zooms them out by an integer factor of 1(1/2, 1/3, 1/4 ...) The image is displayed in the largest factor that fits in the window.
Ignore Aspect Ratio	By default, the width of an image expands to meet the horizontal and vertical ratio of the “field” value (see 3.6.1) on the View Settings Info tab. Select this checkbox to ignore “field” data and display images without horizontal expansion. When only this option is selected and the Fast Display option is also on, the image expands to fill the entire window area.

(4) Scale Settings

Use these functions to set scale display and indicator units.

Name	Function Overview
Horizontal	Show the X-axis in the image window.
Vertical	Show the Y-axis in the image window.
Use Units	Select this checkbox to display labels and axes in physical units and not in pixel units.

3.6.3.3 3D orthogonal Mode

Use this mode to display the three orthogonal sections of 3D data.

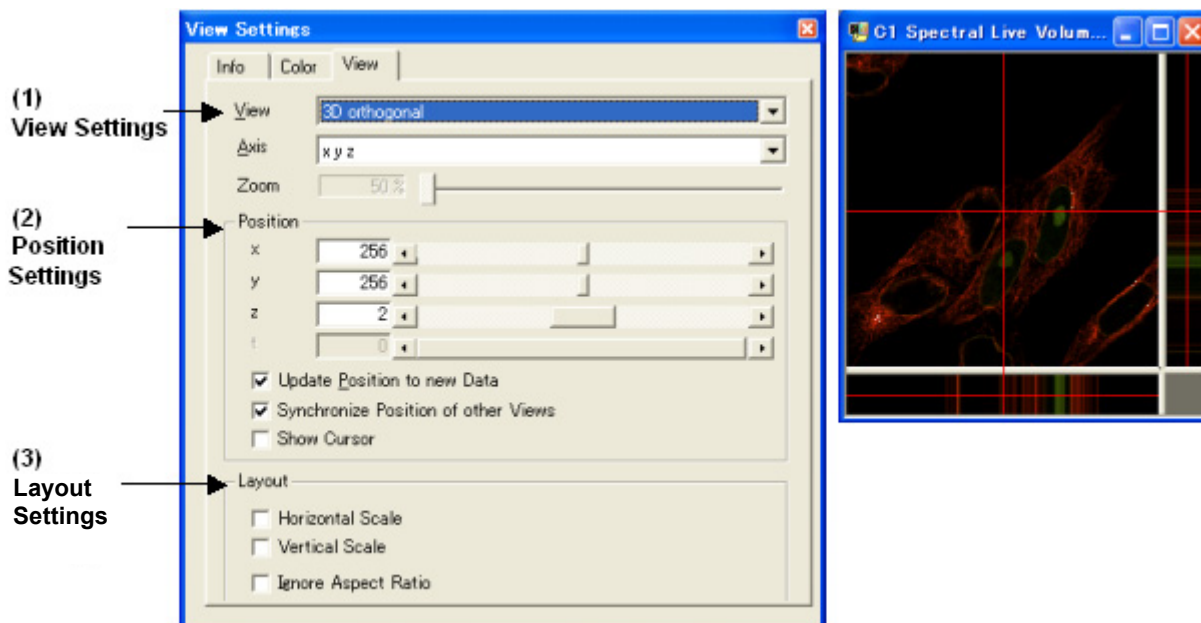

(1) View Settings

Use these functions to make View mode settings.

Name	Function Overview
View	Select the following View mode. (3) 3D orthogonal mode
Axis	Set three axes to display the orthogonal sections of 3D images. Select x, y, z (and t) or y, x, z (and t). (z and t are used only for data with 3 or more dimensions.)

(2) Position Settings

Use these functions to set positions.

Name	Function Overview
x, y, z, t	Use x, y, z and t to specify dimensional locations. (z and t are used only for data with 3 or more dimensions.)
Update Position to new Data	Select this checkbox to display the most recent view of the acquired image. When this option is not selected, the window will show the image according to position slider and cursor settings at all times making it possible to trace image changes manually.
Synchronize Position of other Views	When this checkbox is selected, the position settings of other views of the same image are synchronized. Deselect this checkbox to enable different positions of other views of the same image.
Show Cursor	Select this checkbox to display the cursor at all times. Deselect this checkbox to show the cursor only when the screen is clicked.

(3) Layout Settings

Use these functions to set the calculations used for adjusting scale displays and window size.

Name	Function Overview
Horizontal Scale	Show the X-axis in the image window.
Vertical Scale	Show the Y-axis in the image window.
Ignore Aspect Ratio	By default, the width of an image expands to meet the horizontal and vertical ratio of the "field" value (see 3.6.1) on the View Settings Info tab. Select this checkbox to ignore "field" data and display images without horizontal expansion. When only this option is selected and the Layout option is also on, the image expands to fill the entire window area.

3.6.3.4 3D tiled Mode

Use this mode to show image planes in tiled mode for data with 3 or more dimensions.

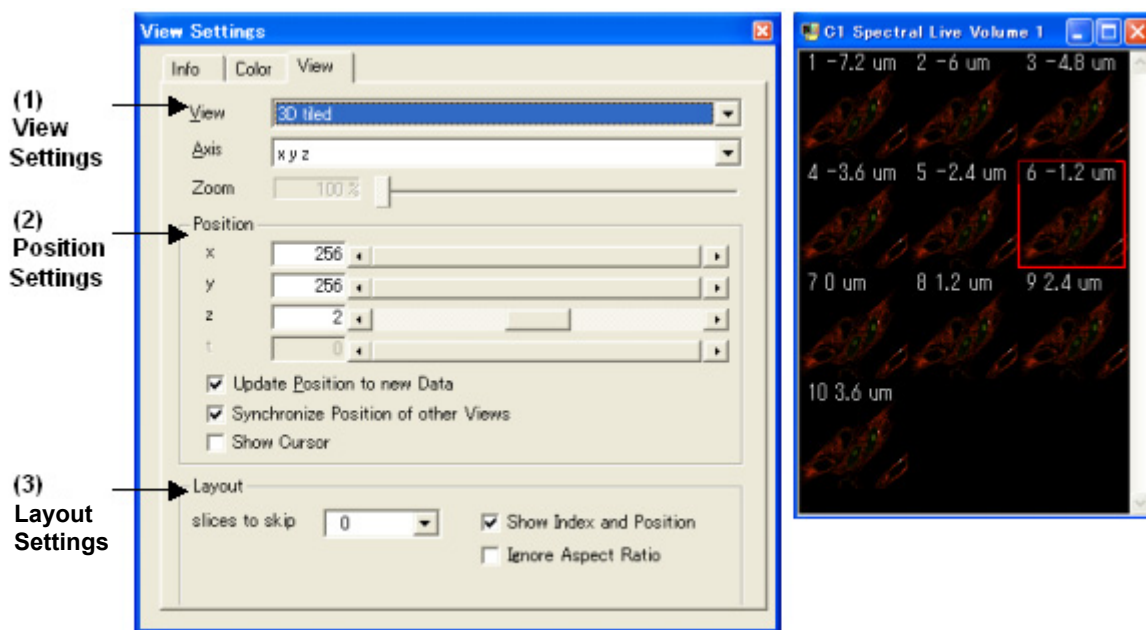

(1) View Settings

Use these functions to make View mode settings.

Name	Function Overview
View	Select the following View mode. (4) 3D tiled mode
Axis	Set three axes to display the orthogonal sections of 3D images. Select x, y, z (and t) or y, x, z (and t). (z and t are used only for data with 3 or more dimensions.)

(2) Position Settings

Use these functions to set positions.

Name	Function Overview
x, y, z, t	Use x, y, z and t to specify dimensional locations. (z and t are used only for data with 3 or more dimensions.)
Update Position to new Data	Select this checkbox to display the most recent view of the acquired image. When this option is not selected, the window will show the image according to position slider and cursor settings at all times making it possible to trace image changes manually.
Synchronize Position of other Views	When this checkbox is selected, the position settings of other views of the same image are synchronized. Deselect this checkbox to enable different positions of other views of the same image.

Show Cursor	Select this checkbox to display the cursor at all times. Deselect this checkbox to show the cursor only when the screen is clicked.
--------------------	--

(3) Layout Settings

Use these functions to set the calculations for adjusting the number of images to display, index and window size.

Name	Function Overview
Slices to skip	Set the number of images to be skipped during image display.
Show Index and Position	Shows labels indicating Index and physical position (or time) on each tiled image.
Ignore Aspect Ratio	By default, the width of an image expands to meet the horizontal and vertical ratio of the "field" value (see 3.6.1) on the View Settings Info tab. Select this checkbox to ignore "field" data and display images without horizontal expansion. When only this option is selected and the Layout option is also on, the image expands to fill the entire window area.

3.6.3.5 2D channel tiled mode

Use this mode to show channel images in tiled mode for data with 2 or more dimensions.

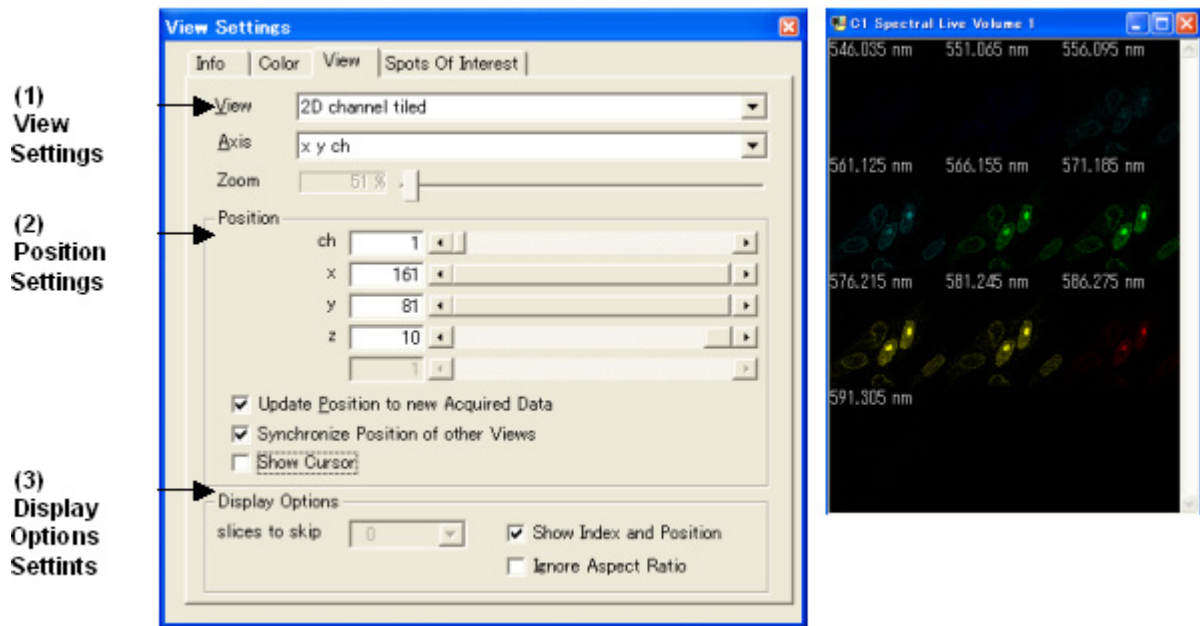

(1) View Settings

Use these functions to make View mode settings.

Name	Function Overview
View	Select the following View mode. (5) 2D channel tiled
Axis	Specify a plane to display the tiled channel data. x, y, and ch are fixed.

(2) Position Settings

Use these functions to set positions.

Name	Function Overview
ch, x, y, z, t	Use ch, x, y, z and t to specify dimensional locations. (z and t are used only for data with 3 or more dimensions.)
Update Position to new Acquired Data	Select this checkbox to display the most recent view of the acquired image. When this option is not selected, the window will show the image according to position slider and cursor settings at all times making it possible to trace image changes manually.
Synchronize Position of other Views	When this checkbox is selected, the position settings of other views of the same image are synchronized. Deselect this checkbox to enable different positions of other views of the same image.
Show Cursor	Select this checkbox to display the cursor at all times.

(3) Display Options Settings

Use these functions to set the calculations for adjusting the number of images to display, index and window size.

Name	Function Overview
Show Index and Position	Shows labels indicating Index and physical position (or time) on each tiled image.
Ignore Aspect Ratio	By default, the width of an image expands to meet the horizontal and vertical ratio of the "field" value (see 3.6.1) on the View Settings Info tab. Select this checkbox to ignore "field" data and display images without horizontal expansion. When only this option is selected and the Display option is also on, the image expands to fill the entire window area.

3.6.3.6 Multi Line mode

When the Time Series graph or the Z-stack graph is active, the View tab enters in the Multi Line mode enabling you to set the graph display method.

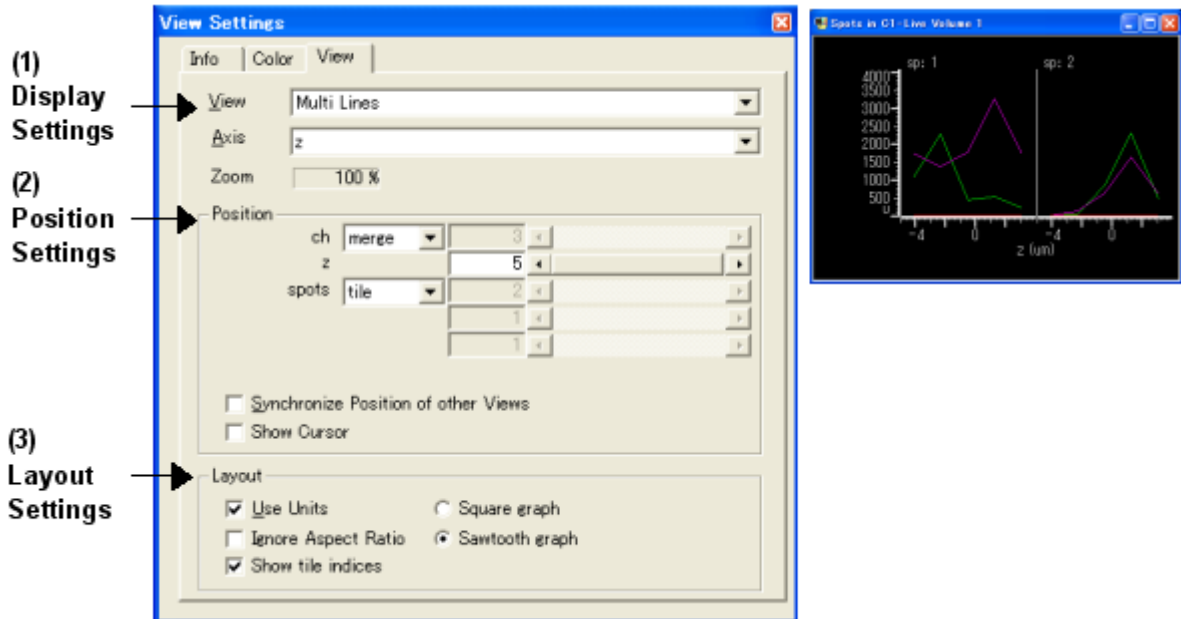

(1) Display Settings

“Multi Line” mode is displayed in “View.” “The horizontal axis of the target graph (z or t)” is displayed in “Axis.”

(2) Position Settings

Position settings are made in this area as follows.

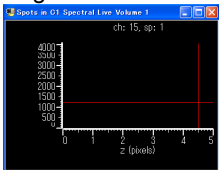
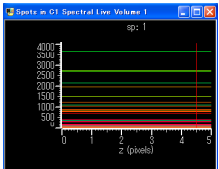
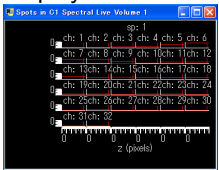
Name	Function Overview
<p>ch</p>	<p>The display method of each channel data is set. Current: Displays a graph for one channel data. Select channel data by using a slider bar.</p>  <p>Merge: Displays graphs for all channel data.</p>  <p>Tile: Graphs for each of the channel data are separately arrayed in tile display.</p> 

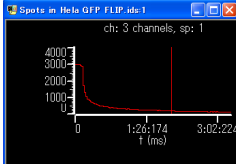
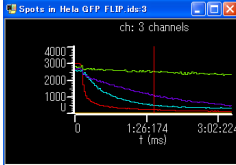
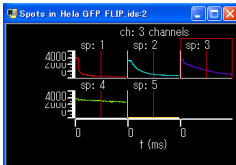
t/ z	Set a cursor position to be displayed when the “Show Cursor” checkbox is enabled. Specify a numeric value.
spots	<p>The display method of each Spot data is set. Current: Displays a graph for one Spot data.</p>  <p>Merge: Displays graphs for all Spot data.</p>  <p>Tile: Graphs for each of the Spot data are separately arrayed in tile display.</p> 
Synchronize Position of other Views	When this checkbox is enabled, the Position settings for one image are linked in the other views. Disable this checkbox to make different Position settings for one image in the other views.
Show Cursor	When this checkbox is enabled, a cursor is always displayed. When this checkbox is disabled, a cursor is only displayed when the screen is clicked.

(3) Layout Settings

Use these functions to set the calculations for adjusting the number of images to display, index and window size.













Name	Function Overview
Use Units	Check this check box to display the image with units of length not with pixels.
Ignore Aspect Ratio	By default, the width of an image expands to meet the horizontal and vertical ratio of the “field” value (see 3.6.1) on the View Settings Info tab. Select this checkbox to ignore “field” data and display images without horizontal expansion. When only this option is selected and the Layout option is also on, the image expands to fill the entire window area.
Show tile indices	Check this check box to display the indices in the tiled images.
Square graph	Displays graph with bar graph-style lines.
Sawtooth graph	Displays graph with broken lines.



3.6.4 View bar

The View bar contains shortcut buttons for the View Settings dialog box (see 3.6). The View bar is the one of the tool window that can be displayed with the EZ-C1 “View bar” on the “Tools” menu.



The View bar contains the following buttons.

Name	Function Overview
	1D graph display mode (see 3.6.3.1).
	2D image display mode (see 3.6.3.2).
	3D orthogonal display mode (block display) (see 3.6.3.3).
	3D tiled display mode (montage display) (see 3.6.3.4).
	2D channel tiled display mode (see 3.6.3.5).
	Gray scale for single channel data (see 3.6.2).
	Pseudo color for single channel data (see 3.6.2).
	Pseudo color for multi-channel data (see 3.6.2).
	True color for spectral data (see 3.6.2).
	These buttons change depending on the number of channels of the active image. <ul style="list-style-type: none"> - With up to 4 channels, the buttons are used to show or hide respective display channel (see 3.6.2). The buttons from left to right correspond to Channels 1 to 4. - With 5 or more channels, a button will be displayed for the spectral data (in the display color for the spectral data), and another button will be displayed for the transition detector data. The buttons can be used to show or hide the data, and are linked to the [Spectral] and [Trans] buttons on the [Transmitted] tab. You cannot hide both data simultaneously.
	Reset button (left): sets the default color mapping. Best button (right): automatically sets the range of brightness levels to which colors are assigned (see 3.6.2).
	Bright button (left): automatically sets the range of brightness levels to which colors are assigned mainly in spectral images (see 3.6.2.1). Contrast + button (center): raises the saturation level by 1. Contrast – button (right): lowers the saturation level by 1.
	Show/hide the View Settings tool (see 3.6).

	Show the Description window (see 4.1.9).
	Create a new window for the active image (see 4.10).

3.6.5 Transmitted Tab

The View Settings | Transmitted tab is displayed when you select an image window that contains “spectral + transmission detector data”.

It can be used to set the “Blending of spectral and transmission detector data” and the intensity scaling for the transmission detector data.

For a Z-stack observation data, you can select a transmission detector data slice in focus, and overlay it on the fluorescent images of all Z-slices.

The transmission detector data is shown in grayscale.

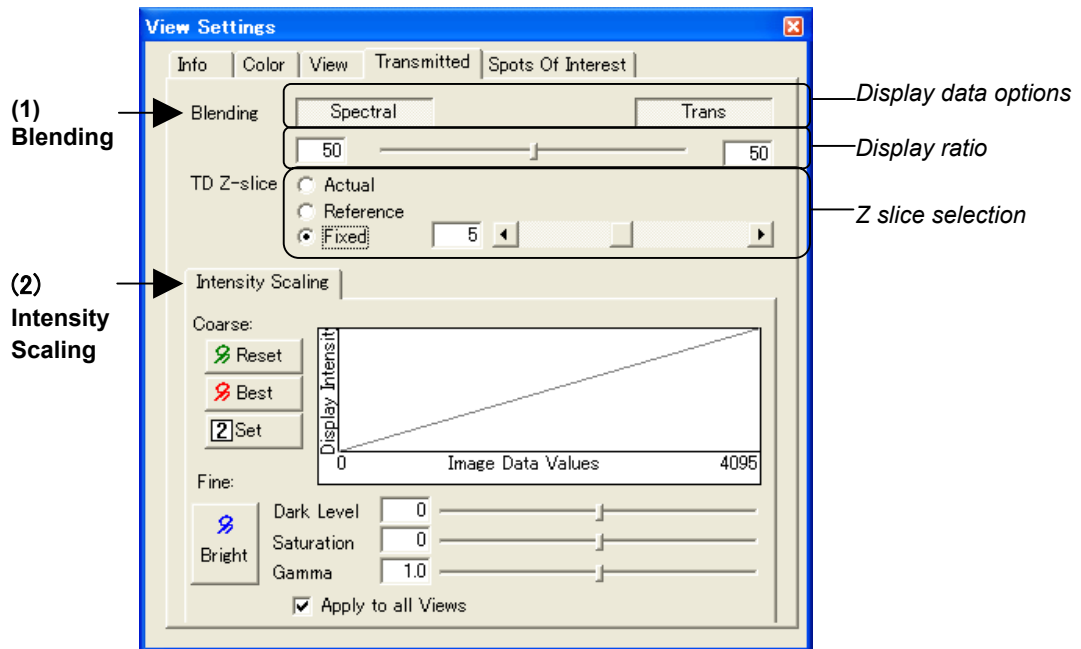

(1) Blending

Sets the blending of the spectral data and the transmission detector data. You can set whether to show each data, and in what ratio.

Name	Function Overview
	Shows the spectral data. [Spectral] button only: Displays the spectral data only. [Spectral] button + [Trans] button: Displays the spectral data and the transmission detector data in the specified ratio.

<p>Trans</p>	<p>Shows the transmission detector data. [Trans] button only: Displays the transmission detector data only. [Spectral] button + [Trans] button: Displays the spectral data and the transmission detector data in the specified ratio.</p>
<p>Display Ratio</p>	<p>Sets the overlay ratio for the spectral data and the transmission detector data. This ratio is used when the [Spectral] button and the [Trans] button are both depressed.</p>
<p>Z slice selection</p>	<p>For Z-stack observation data, you can select the transmission detector data to overlay. Actual: Overlays the transmission detector data acquired at each Z position on the fluorescent images. Reference: Overlays the transmission detector data acquired at the reference position on the fluorescent images of all Z-slices. Fixed: Select a transmission detector data slice in focus, and overlay it on the fluorescent images of all Z-slices.</p>

(2) Intensity Scaling

Sets the color brightness for the transmission detector data.

See “(3) Intensity Scaling” under “When an Image Acquired by Spectral Detector is Active” in “3.6.2.1 Multi Channel Pseudo Color Mode”.

3.7 Laser Control

The Laser Control Bar dialog box (Figure 3.7-1) is used to control the brightnesses of lasers and to specify the bleach mode settings. The Laser Control Bar dialog box is displayed by selecting the Laser Control Bar command on the Tools menu of EZ-C1.

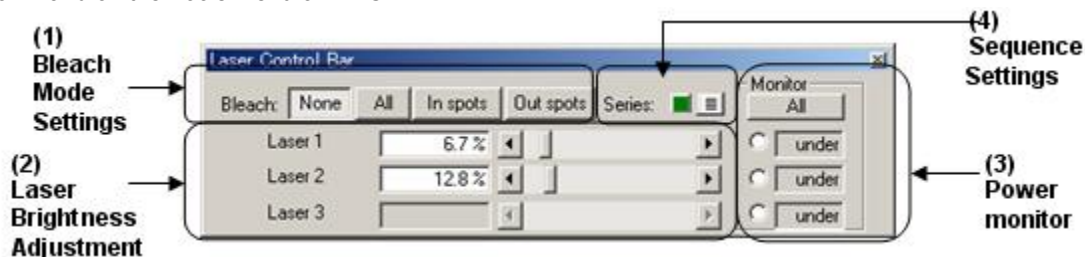

Figure 3.7-1 Laser Control Bar dialog box

(1) Bleach Mode Settings

Specify the settings for the bleach mode. (This setting is used only for a case where no sequence is created.) To adjust the laser brightness of the standard scanning, select [None].

Name	Function Overview
[None]	Not bleached. To adjust the laser brightness of the standard scanning, select this option.

[All]	All scanning area is bleached. ! The laser power is the specified value in the bleach mode settings for [All], [In spots], and [Out spots].
[In spots]	The area in the spot is bleached. ! The laser power is the specified value in the bleach mode settings for [All], [In spots], and [Out spots].
[Out spots]	The area out of the spot is bleached. ! The laser power is the specified value in the bleach mode settings for [All], [In spots], and [Out spots].

Note

(1) Spots to be bleached:

Only the spots that are specified as ON in the Bleach field on the Spot of Interest tab of the View Settings dialog box will be bleached. (Refer to 4.3.6.)

(2) Laser power for areas not to be bleached:

The laser power for areas not to be bleached is set to 0%.

(3) Example of bleaching:

(The ON area and OFF area are specified in the Bleach field. See the Note (1) above.)

(1) In spots



(2) Out spots



(3) In spot (Two spots are overlapped.)

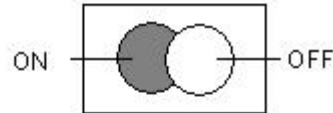
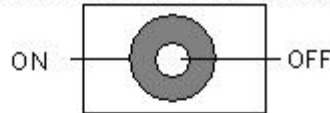

(4) Out spot (Two spots are overlapped.)

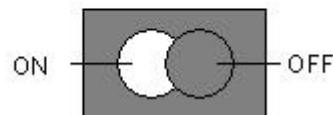

(2) Laser Brightness Adjustment

Adjust the brightness of the lasers for the standard scanning and the bleaching.

Specify the bleach mode in (1) Bleach Mode Settings and then, adjust the laser brightness.

When the bleach mode is [None],

adjust the laser brightness for the standard scanning.

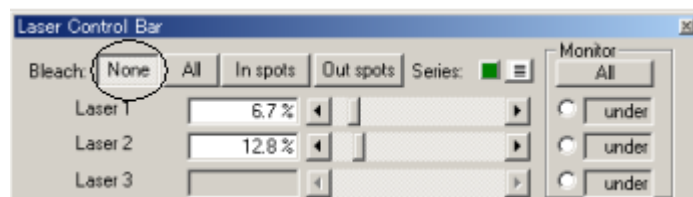

When the bleach mode is [All], [In spots], or [Out spots], adjust the laser brightness for the bleaching. The color of the control bar becomes red, and the brightness settings are used in common among three modes.

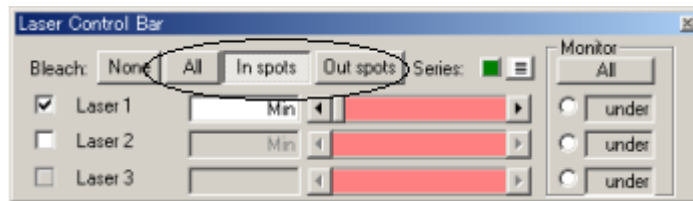

Name	Function Overview
<input checked="" type="checkbox"/> (Checkbox)	Check the laser to be used for bleaching. Only the laser checked here is adjustable for the brightness. ! To adjust the laser brightness, specify the details on the Lasers tab of the Configure Confocal C1 dialog box. On the Laser tab, the laser can be controlled in % or Voltage unit. (Refer to 5.2.1.)

(3) Power monitor

This area can be used for the laser brightness adjustment for the standard scanning and bleaching.

Name	Function Overview
Monitor	The laser power at the moment will be displayed. It can be used as a guideline of the brightness adjustment.
<input type="button" value="All"/> [All]	Every laser power is monitored once in sequence.
<input type="checkbox"/> (Checkbox for each laser)	Check the checkbox for a laser to be monitored. Images can be viewed in real time. A laser power can be checked while adjusting the brightness. If the checkbox is not checked, no laser power is monitored. - No laser power can be monitored when scanning. A laser power can be monitored when scanning is stopped. Besides, check the "Park mirrors when idle" option on the Mirrors tab of the Configure Confocal C1 dialog box to prevent laser light from applying on the specimen when scanning is stopped. (Refer to 5.2.4.)

(4) Sequence Settings

Specify the settings for the Time series Variable Delay function in the Sequence Settings area of the Laser Control Bar dialog box. These settings are interlocked with the settings in the Acquire Settings dialog box.

Name	Function Overview
Series <input checked="" type="checkbox"/>	Press this button to turn on the Time series function.
<input type="button" value="Menu"/> (sequence)	Specify the settings of the Time series Variable Delay function. (For details about the settings of the sequence, refer to 3.5.6.1.)

Note

- A FRAP sequence can be performed by using the Variable Delay function. For details, refer to appendix A.1 "FRAP Sequence Macro."

3.8 Laser Power Monitor

A laser power can be monitored in the Laser Power Monitor dialog box. To display this dialog box, select the Laser Power Monitor command in the EZ-C1 Tools menu.



Figure 3.8-1 Laser Power Monitor dialog box

Name	Function Overview
Laser Power	The latest laser power is shown 0 to 100 in steps of 0.1 in this field.
[Measure]	Push this button to monitor the total power of the laser in use. The laser power value will be refreshed.
[Settings]	Specify the settings to monitor the laser power. (Such as automatic monitoring and so on.) For details, refer to 5.2.2.

Note

- When a three-laser unit is used for the system, the laser power can be monitored during scanning. Besides, the laser power monitor value and the image at the beginning of a scanning can be saved when appropriate settings are specified with the [Settings] button. (Monitoring is not available if the laser is shielded (as described in 5.2.1, using the “Mask lasers during the mirror retrace” function on the Lasers tab).)
- When a four-laser unit is used for the system, the laser power cannot be monitored during scanning. The laser power value can be monitored only when no scanning is being performed.

3.9 Objective Bar

Objectives can be changed with the Objective Bar dialog box. To display this dialog box, select the Objective Bar command in the EZ-C1 Tools menu.

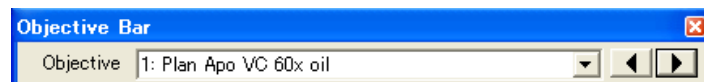

Figure 3.9-1 Objective Bar dialog box

Name	Function Overview
Objective	Select the magnification of the objective to be used. The magnification is used to calculate the x- and y-position in the field of view. When “Other ...” is selected, the Configure Objectives dialog box appears. (Refer to 4.2.3.) Press the [Change] button in the dialog box to change the magnification.
	Press this button to change objectives sequentially. Objectives can be set up to six locations.

Note

- If "None" is selected here, the value of "Calibration @ 100x Objective" on the "Mirrors" tab in the "Configure Confocal C1" dialog box (see 5.2.4) is used to calculate the position of the field of view and X/Y position.

< When the TE2000 is used >

- When the TE2000 is used, the EZ-C1 obtains the objective database information from the TE2000 when it starts.

Note also that you can control changes in the TE2000's objective using the Acquire Settings tool.

To rotate the TE2000's revolving nosepiece, click   on one of the buttons or select a desired objective from the list box to the right of "objective" using the XY control tool.

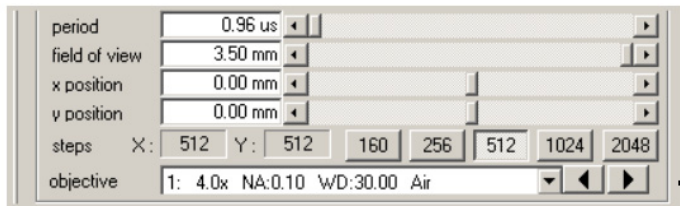

Click to rotate the revolving nosepiece one step at a time. (When a device other than the TE2000 is used, you can select the desired objective only by scrolling through the list box.)

Figure 3.9-2 Scan Settings

Note that the objective-lens information stored in the "objective" list box represents the information available at the time of EZ-C1 startup. Therefore, if any objective lens is replaced during EZ-C1 operation, you need to startup again.

- When the TE2000 is used, its objective database is used. As a result, you cannot edit the objective information.

< When AZ100 and RFA are used >

- When the combination of AZ100 and RFA is controlled, selection on Objective Bar includes both objective magnification and zoom rate.

The "total magnification" (objective magnification × zoom rate × 0.6) that includes the zoom rate of AZ100 is set for the magnification to be used.

Before selecting an objective from Objective Bar, check the zoom rate setting of AZ100 and select it together.

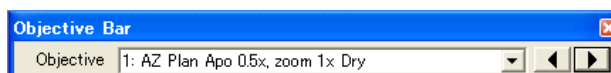
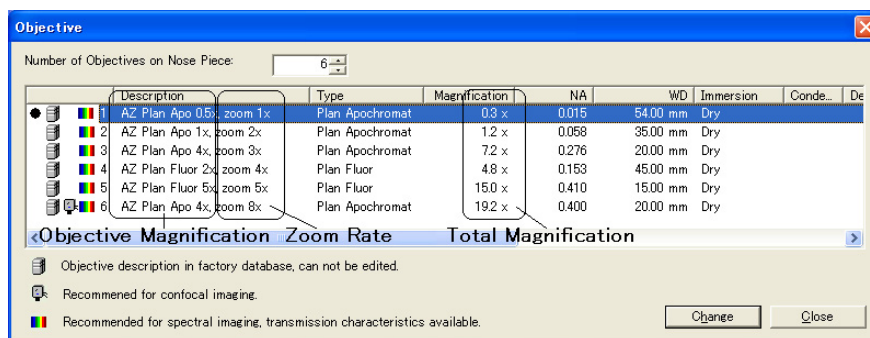

3.10 CLEM Bar

When CLEM equipment is connected, select the CLEM Bar command in the Tools menu to display the CLEM Bar dialog box. In the CLEM Bar dialog box, you can activate and deactivate CLEM functions and change the dynamic range (Normal or Wide).

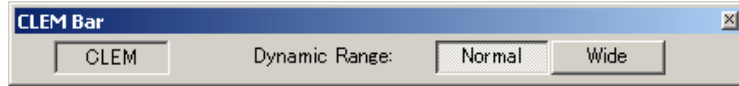

Figure 3.10-1 CLEM Bar dialog box

Name	Function Overview
<input type="button" value="CLEM"/>	Activates or deactivates CLEM functions.
<input type="button" value="Normal"/> <input type="button" value="Wide"/>	Toggles the dynamic range (Normal or Wide).

CAUTION

- CLEM functions cannot be used in spectral mode. They are enabled only in standard mode.
- CLEM functions cannot be used when the four-laser unit is connected. They are enabled only when the three-laser unit is connected.

4

Menu Functions

Chapter 4, “Menu Functions” describes EZ-C1 menu functions. Information on the functions of EZ-C1 compliant devices is provided in Chapter 5, “Hardware-related Settings.”

4.1 Files

The File menu contains entries to load and store images, print images, change the information of the images and to terminate the program.

4.1.1 Open

The File Open dialog box (Figure 4.1-1) is shown with the EZ-C1 “Open” command on the “File” menu. The dialog is a standard Windows File Open dialog with features similar to Windows Explorer. The lower field allows for showing all files or only those of one of the supported file types.

For supported file types, please refer to the “Appendix B. Data File Formats.” The File Open dialog box is opened from the File bar (see 4.1.12).

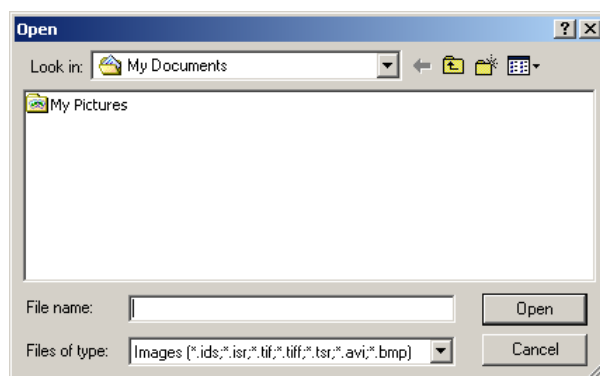

Figure 4.1-1 Open dialog box

4.1.2 Close

Use the “Close” command on the “File” menu to close the active image window. If the image has been changed, a “Save and Terminate” dialog box (Figure 4.1-2) will be displayed. Note that unlike the “Exit” command, there is no functional difference here between selecting [No] and [Save None].

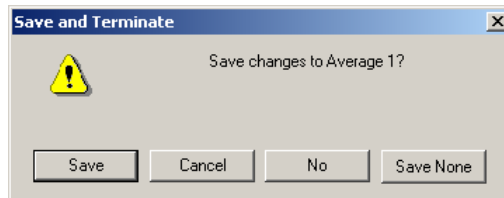

Figure 4.1-2 Save and Terminate dialog box

Name	Function Overview
[Save]	Causes the “Save As” dialog box to be displayed so the image can be saved to a file.
[Cancel]	Causes the window to remain open without saving the image to a file.
[No]	Causes the window to close without saving the image to a file.
[Save None]	Causes the window to close without saving the image to a file.

Note

- The Live window and the window created through a New command on the Window menu will not close.

4.1.3 Save

The EZ-C1 “Save” command on the “File” menu saves the active image to disk. Depending on the Save Options (see 4.2.4), the “Save As” dialog box (Figure 4.1-3) will appear. The “Save” command on the “File” menu is available on the File bar (see 4.1.12).

Note

- The table below shows the calculated maximum amount of data that can be saved into a single file.

	File system	
	FAT32	NTFS
Maximum size	4GB	2TB

4.1.4 Save As

The EZ-C1 “Save As” command on the “File” menu saves the active image to disk. The Save As dialog (Figure 4.1-3) appears to enter the new file name.

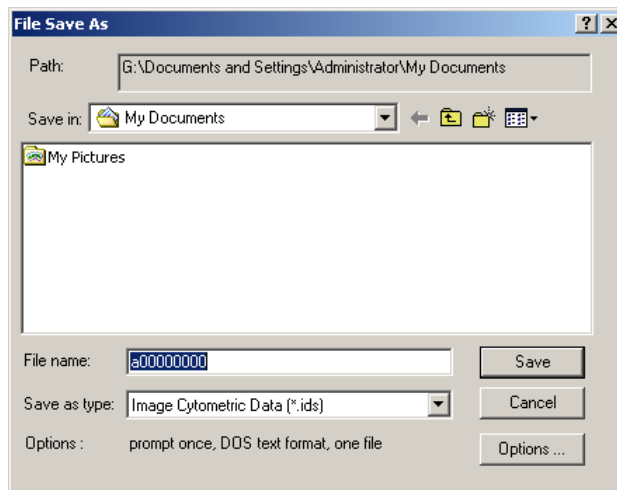

Figure 4.1-3 Save As dialog

The “Save As” dialog contains the following items.

Name	Function Overview
Path	The full path name of the current directory
Save in	The folder name to be saved in
File name	The name of file
Save as type	The file type to be used to save. Currently supported file types are ids, tiff, bmp, avi, and xls. Refer to the “B Data File Formats” for information about the file formats. - Files saved in the Data Series graph window are saved in the “esd” format.
Options	The current selected Save options
[Options...]	Press this button to change the save options (see 4.1.5).

4.1.5 Save As Options

The Save As Options dialog box is shown when the [Options ...] button of the Save As dialog box is pressed. The dialog box contains the Save Options tab (see 4.2.4), as well as, depending on the selected file type, the Ics Options tab (see 4.1.5.1), the Tiff Options tab (see 4.1.5.2), the AVI Options tab (see 4.1.5.3), or the Excel Options tab (see 4.1.5.4). The Bitmap format does not have any options.

4.1.5.1 Ics Options

The Ics Options tab (Figure 4.1-4) appears when the [Options...] button is pressed and the Ics format is selected in the Save As dialog box. The Ics Options tab contains the following items.

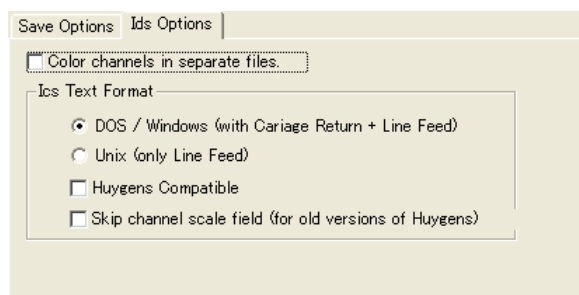

Figure 4.1-4 Ics Options Tab

Name	Function Overview
Color channels in separate files	Check this box to save the color channels to separate files. For each color channel an ics/ids pair is created. In addition, the normal ics file is written. To reload the split image into EZ-C1 as a single color images, a file with the extension .isr is created that holds the names of the color channels files.
Ics Text Format	The ics files can be written in DOS / Windows text format that uses carriage return (CR) and linefeed (LF) combination as line separator, or in the Unix text format that uses linefeed (LF) only. Use the Unix text format if your image processing application rejects the DOS CR line separator.
Huygens Compatible	Check this box to create an ics file using the format defined for compatibility with "Bitplane Imaris" and "SVI Huygens deconvolution" software.
Skip channel scale field (for old versions of Huygens)	Check this box to skip writing of the channel scale field for the earlier versions of Huygens compatible formatted software.

4.1.5.2 Tiff Options

The Tiff Options tab (Figure 4.1-5) is shown when the tiff format is selected and the [Options ...] button is pressed on the Save As dialog box. The Tiff Options tab contains the following items.

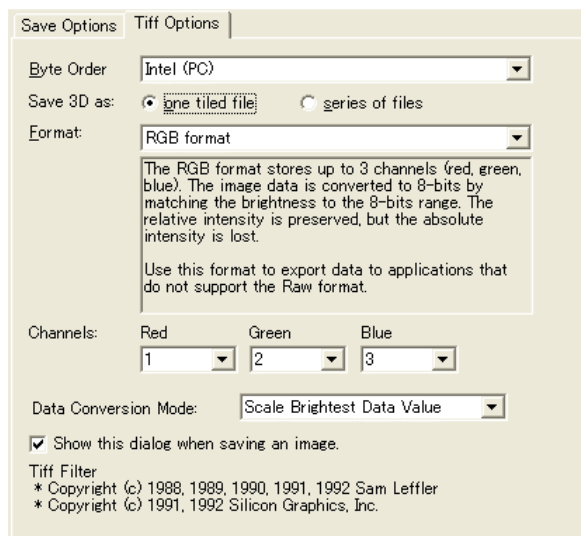

Figure 4.1-5 Tiff Options tab

Name	Function Overview
Byte Order The following byte orders are supported.	
Intel (PC)	Use this byte order when writing images using Intel-based computers.
Motorola (Mac)	Use this byte order when writing images using Motorola-based computers (Macintosh).
Save 3D as When 3D files are saved, the image slices can be saved in one file or in separate files.	
one tiled file	Check this option to store all slices in one file.
series of files	Check this option to save each slice in a separate file with an incremented index (**_001.tiff, **_002.tiff, ...). In addition to the slice files, an ascii file is written with the extension .tsr (tiff series) that contains the names of the slice files. When this file is opened with the "Open" command on the "File" menu, all slice files are read and the 3D image is reconstructed. When copying or moving series of files, be sure to keep the slice files and the .tsr file together.
Format The image can be stored as.	
Raw format	The Raw format stores all data without color information or conversion. Use this format to export the image data for analysis purposes. However, there are not many programs that are able to read the raw data format.

RGB format	<p>The RGB format stores up to 3 channels (red, green, blue).</p> <ul style="list-style-type: none"> - 12-bit data for each channel is converted to 8-bit data and saved. (For a conversion mode, see Data Conversion Mode below.) - In this format, you can allocate color of channels. (For a setting method, see Channels below.) <p>Re-opening this format image, channels are assigned in order of RGB. Most application software supports 24-bits RGB images. Use this format to export data to application software that does not support the Raw format.</p>
Bitmap format	<p>The Bitmap format stores a copy of the currently active window. The image data is saved as a 24-bit RGB tiff image that appears to the eye just like the image displayed in the window. Select this format when you wish to save figures and text along with an image using the annotation function. Use this format for presentation purposes.</p>
1-Channel 8-Bit format	<p>Specified one channel data is saved as 8-bit Gray tiff data. (For details on how to convert 12-bit data to 8-bit data, see Data Conversion Mode below.)</p>
1-Channel 16-Bit format	<p>Specified one channel data is saved as 16-bit Gray Tiff data. (For details on how to convert 12-bit data to 16-bit data, see Data Conversion Mode below.)</p>
Channels	<p>Select the color for each channel. This option can be used only for the RGB format.</p>
Data Conversion Mode	
12-bit data can be converted to 8-bit or 16-bit in the following modes.	
Scale Brightest Data Value	<p>Data is adjusted based on the brightest data so that dynamic range fits in 8-bit or 16-bit. This mode is also available even when data is not an integer type.</p>
Scale Full Range	<p>By cutting (adding) low four bits of (to) 12-bit data, the 12-bit data is converted to the eight bit (16-bit) data. Fine gradation is lost. However, dynamic range is retained. Note that this mode is only available when data is an integer type. The Scale Brightest Data Value setting is applied in this case.</p>
Show this dialog when saving an image	<p>Check this option to show this dialog box each time save button on file save as dialog is pushed. Use this option to check an image format and color assignments.</p>

Note

- All channel data of Tiff data of 1-Channel 8-Bit, 1-Channel 16-Bit, and Bitmap format can be serially saved by batch processing using the Tiff Series Export function.

Tiff Series Export function: it is registered in the Macro menu by loading the Tiff Series Export macro. For details, see Section A10, "Tiff Series Export Macro."

4.1.5.3 Avi Options

The AVI Options tab (Figure 4.1-6) is shown when the avi format is selected and the [Options ...] button on the Save As dialog box is pressed. The AVI Options tab contains the following items.

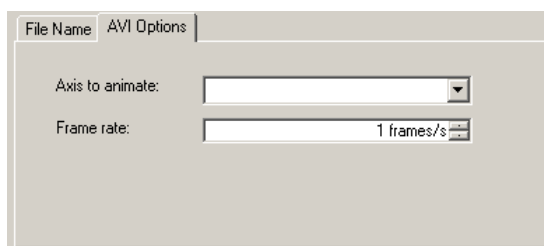

Figure 4.1-6 AVI Options tab

Name	Function Overview
Axis to animate	The Avi movie is created by animated one of the axis indices and capturing the image as drawn in the view. Select which axis is animated here.
Frame rate	The number of frames per second with which the 3D image is animated when played with the Windows Media Player 6.0 or other compatible Avi players.

4.1.5.4 Excel Options

The Excel Options tab (Figure 4.1-7) is shown when the xls format is selected and the [Options ..] button on the Save As dialog box is pressed.

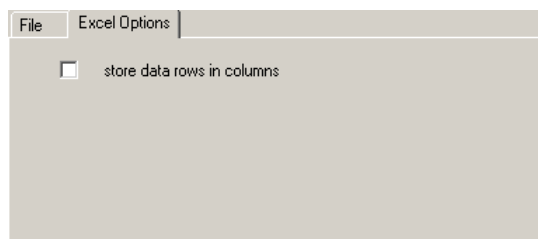

Figure 4.1-7 Excel Options tab

The Excel Options tab contains the following item.

Name	Function Overview
store data rows in columns	Check this option to transpose column data and row data. Excel can record data in every 1 line only to 255 rows. However, column data is not bound by the maximum number (255) applying to rows. Use this option to save more than 255 lines of data.

4.1.6 Print

The EZ-C1 “Print” command on the “File” menu prints the active window. To specify the printer and print parameters, display the default Windows Print dialog box. The image is stretched to fill the paper.

To print a smaller image, you can define a smaller paper size in the Print Setup dialog (see 4.1.8). Please refer to the instruction manual supplied with your printer. The “Print” command on the “File” menu is also available from the File bar (see 4.1.12).

4.1.7 Print Preview

The EZ-C1 “Print Preview” command on the “File” menu displays the image on the screen as it will be printed to paper. The Print Preview command is also available from the File bar (see 4.1.12). The top menu bar of the Print Preview window contains the following buttons.

Name	Function Overview
Print	Print the image.
Magnify	Magnify the preview image by up to two levels.
Close	Close the Print Preview window without printing.

4.1.8 Print Setup

The EZ-C1 “Print setup” command on the “File” menu displays the Windows Print Setup dialog box. This dialog box allows for selection of the printer, paper size and orientation. Please refer to the instruction manual supplied with your printer.

4.1.9 Description

Use the “Description” command on the “File” menu to open the Description dialog box (Figure 4.1-8) and enter comments for currently active images.

The comment should reflect measurement type, sample and other experimental parameters. (The contents of the comment may automatically be updated when the image is saved. For example, when an image is saved, the current date and time are entered in the Date field by default.)

Note

- This dialog box can also be opened using the File menu | Description command and the View bar |  button.
- This comment is saved in the ids or text format together with the image. No other file format can be used.

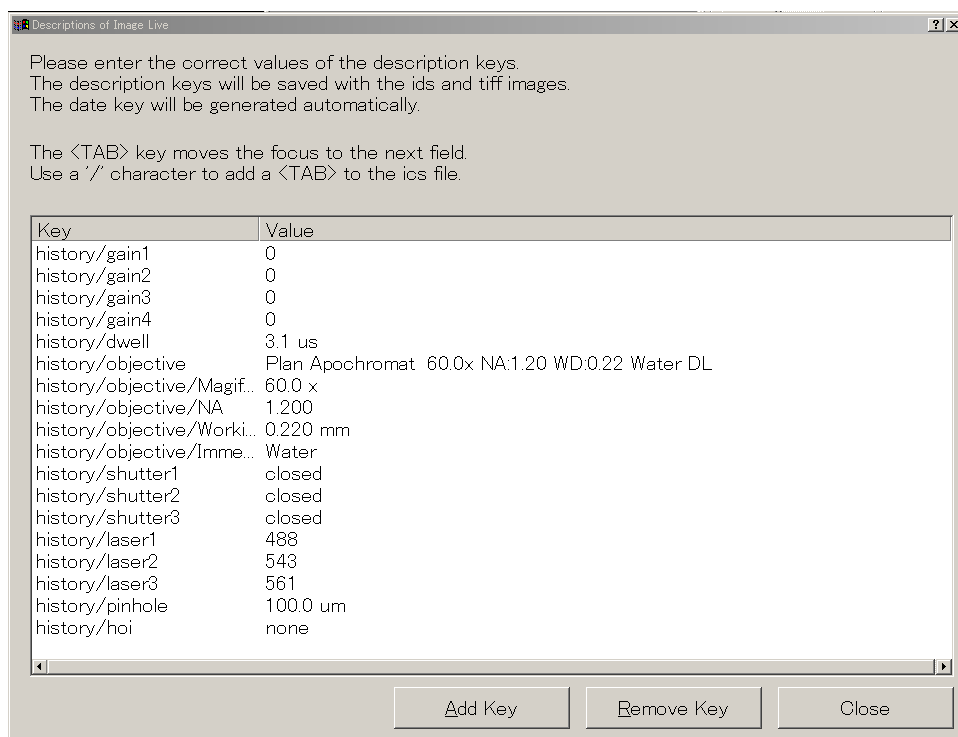

Figure 4.1-8 Description dialog box

4.1.10 Recent Files

The EZ-C1 “Recent File” entries 1 to 9 on the “File” menu allow easy opening of the last 9 saved images.

4.1.11 Exit





The EZ-C1 “Exit” command on the “File” menu terminates the program. If unsaved images are present, the Save and Terminate dialog box (Figure 4.1-2) appears. This dialog box can also be accessed by “Close” command on the “File” menu (see 4.1.2). The Save and Terminate Dialog contains the following buttons.

Name	Function Overview
[Save]	Save the unsaved image before termination.
[Cancel]	Do not terminate the application.
[No]	Do not save the image and terminate the application.
[Save None]	Don't save any unsaved image and terminate the application.

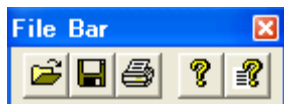
4.1.12 File Bar

The File Bar contains shortcut buttons for menu commands from the File and Help menus. The File bar is a Tool window (see 4.8) that can be displayed with the “File bar” command on the EZ-C1 “Tools” menu. The File bar contains the following buttons.



Name	Function Overview
 File Open	Open an existing image (see 4.1.1).
 File Save	Save current image to file (see 4.1.3).
 File Print	Print current image (see 4.1.6).
 Help About EZ-C1 for Nikon C1 Confocal Microscope	Opens About EZ-C1 for Nikon C1 Confocal Microscope. Use this Help screen to confirm the EZ-C1 version or hardware version.
	Help EZ-C1 Help: Opens EZ-C1 Help screen

4.2 Configure

The Configure menu lets you configure the device, select objectives, or make default settings for the name of the file in which to save an image.

- Devices (see 4.2.1)
- License (see 4.2.2)
- Objectives (see 4.2.3)
- Save Options (see 4.2.4)
- Startup Profile (see 4.2.5)
- Acquire Option (see 4.2.6)

Note

- If other modules are added, the Configure menu may also contain commands other than the above. For more information on setting additional modules and on settings made in Confocal C1, refer to Chapter 5, "Hardware-related Settings."

4.2.1 Devices

The Configure Devices dialog box opened by the Devices command on the Configure menu (Figure 4.2-1) allows for setting the installed device drivers. The configuration is stored in a file with the extension .ini.

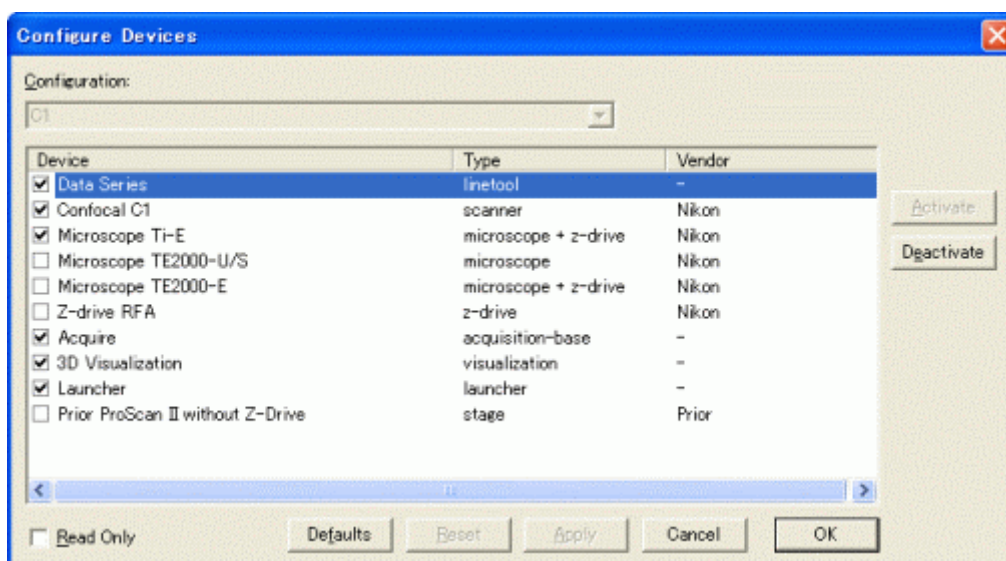

Figure 4.2-1 Configure Devices dialog box

Name	Function Overview
Configuration	Shows the name of the current configuration.
Read Only	Check this option to protect the current configuration. When this option is checked, a dialog box appears to confirm whether save changes or not when the [OK] button is pressed.
Device	This field lists the device drivers that are available in this configuration. A leading check mark indicates that a device is active.

[Activate]	Press this button to activate the selected device.
[Deactivate]	Press this button to deactivate the selected device.
[Defaults]	Press this button to activate the default combination of devices.
[Reset]	Press this button to reset the configuration to its initial state.
[Apply]	Press this button to save the changes without closing the dialog box.
[Cancel]	Press this button to discard the changes and close the dialog box.
[OK]	Press this button to save your changes and close the dialog box. EZ-C1 will restart.

Note

- The Configure Devices dialog box is available only if the user has logged in with administrator rights.

4.2.2 License

The Nikon HASP dialog box displayed by the License command under the Configure menu (Figure 4.2-2) lets you confirm the contents of the license for the currently used dongle (hardware protect key).

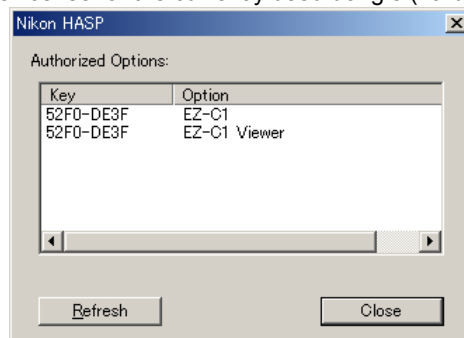

Figure 4.2-2 Nikon HASP dialog box

Name	Function Overview
Key	License number
Option	Application name
[Refresh]	Reloads license information from the dongle.
[Close]	Closes the window.

4.2.3 Objectives

In the Objective dialog box (Figure 4.2-3) displayed by clicking the Objective command on the Configure menu, you can create a list of current objectives in the objective Bar dialog box (See 3.9).

Images are acquired using the objective lens for which the corresponding check box on the left edge of the dialog box is selected (see Note).

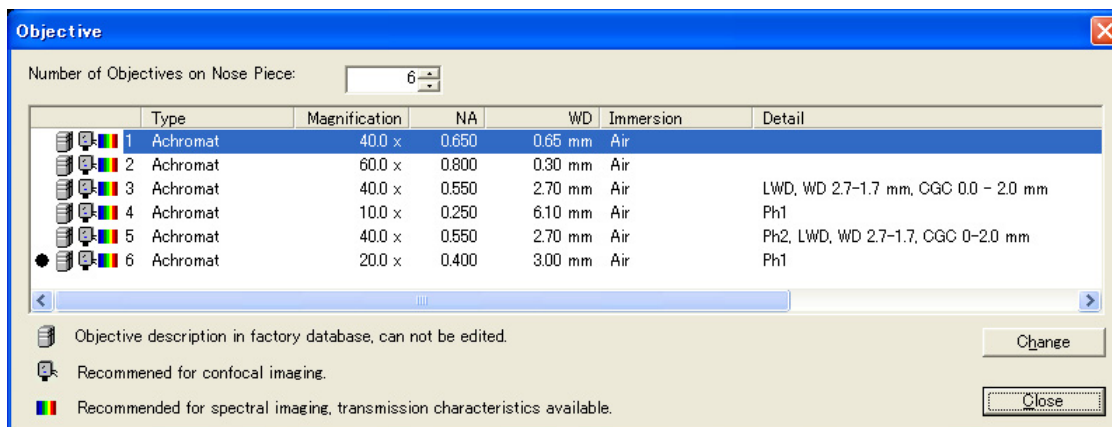





Figure 4.2-3 Objective dialog box

-  : Objective lens data stored in EZ-C1
-  : Data for recommended confocal objective lens
-  : Data for spectral objective lens (containing transmission characteristics and enabling brightness calibration).

To alter the list display, select and double-click on an objective, or click [Change] to display the Select New Objective dialog box (Figure 4.2-4). Use [Select] to assign the objective to the objective mounting position selected in the Objective dialog box. Note, however, that you cannot alter or delete information registered by default.

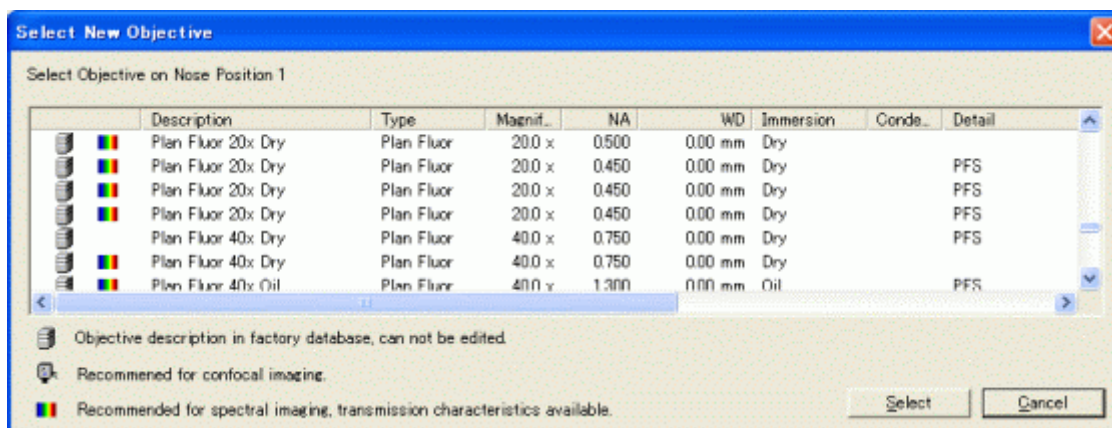

Figure 4.2-4 Select New Objective dialog box

Note

- Information on the objective lens used to acquire the image is saved with an image (see 4.1.9, "history/objective" lines in the Description dialog box). The objective lens information is used to calculate the scan area for image acquisition (see 3.4.7, "field of view"), other settings based on the scan area (i.e., Scale on the View tab in the View Settings dialog box [see 3.6.3], the scale of the Ruler on the Annotate menu [see 4.3.2], the value set for the Distance on the Analyze menu [see 4.3.1.1], the Spot area indication [see 4.3.6] and the like), and the SyQuest value of Z-stack (see 3.5.5).
- Before the acquired image can be correctly measured, the scanning mirror must be calibrated. (See 5.2.4, Calibration@100xobjective)

4.2.4 Save Options

Select the Save Options command from the Configure menu to display the Configure Save dialog box. Here you can set default settings for file names to be saved, etc.

Click the Save Options tab (Figure 4.2-5) to make settings for the filenames generated automatically when saving an image with the Save command or the Save As command from the File menu.

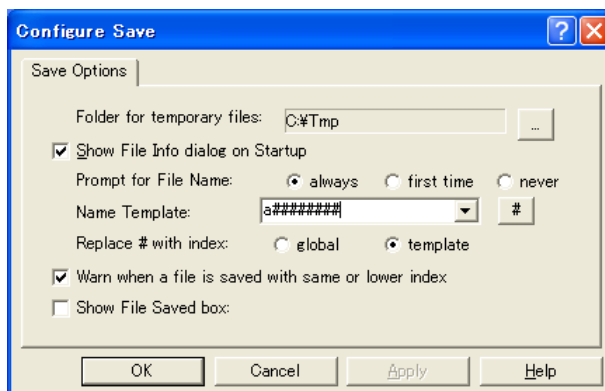

Figure 4.2-5 Save Options tab on Configure Save dialog box

Name	Function Overview
Folder for temporary files	Specify a working folder for temporary storage of images during image acquisition. [...]: This button lets you browse existing folders and select one from the list. - The disk on which the working folder is located must have at least as much free space as the file size of the acquired image.
Show File Info dialog on Startup	Select this check box to display the current settings in the Description dialog box on EZ-C1 startup.
Prompt for File Name	Specify when to display the Save As dialog box when you select the Save command on the File menu.
always	The Save As dialog box is displayed each time you save an image.
first time	The Save As dialog box is displayed only the first time you record an image (i.e., before any other images have been saved).
never	The Save As dialog box is not displayed. Images are saved under automatically generated filenames.
Name Template	The name template is used for automatic generation of file names. The # signs in the file name are replaced with an index number to obtain a unique file name. The index numbers are increased each time an image is saved with this template. To prevent generation of files with similar names, be sure to set the name template to a string that is unique in your laboratory. [#]: Enter the format of the sequential numbers to be assigned to filenames. - To avoid generating files with similar names, for each observation session, we recommend resetting Name Template to a string that can easily be distinguished from previously assigned names.

Replace # with index Specify the serial number for [#] used in the Name Template.	
global	The number of [#] increases each time the image data is saved by the current log-in user. Regardless of the saved filename the number increases.
template	The number of [#] increases in case the image data is saved with the same file name.
Warn when a file is saved with same index	Select this check box to display the File Count Warning dialog box (Figure 4.2-6) if the operator attempts to save a file under a filename assigned to an existing file. You can also enter a setting in this dialog box to auto-increment numbers embedded in filenames. Deselect this check box to display an overwrite confirmation dialog instead of the File Count Warning dialog box. This lets you change filenames manually.
Show File Saved box	Selecting this checkbox displays a dialog after you save a file that prompts for confirmation of a filename. Use this option to confirm the saved filename if you selected “never” for the Prompt for Filename option.

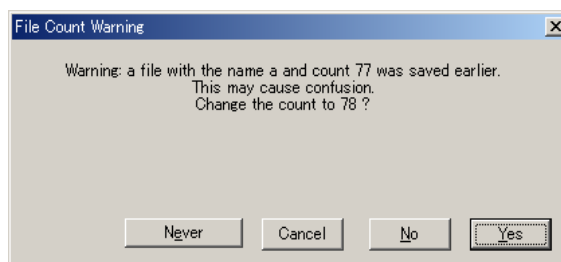

Figure 4.2-6 File Count Warning dialog box

Name	Function Overview
[Never]	Disables automatic incrementing of filename sequence numbers. An overwrite confirmation dialog box is displayed. From this point on, this dialog box will not be displayed. (The check box in Figure 4.2-5 is unselected.)
[Cancel]	Returns to the File Save As dialog box, allowing you to rename the file manually.
[No]	Disables automatic incrementing of filename sequence numbers. An overwrite confirmation dialog box is displayed.
[Yes]	Saves files under different (incremented) sequence file numbers.

4.2.5 Startup Profile

Selecting a profile allows you to reuse previously saved settings, which may be in groups of each user, each experiment, or other classification.

Each profile (ezi file) contains ini file settings.

While the EZ-C1 is in operation, the profile selected during starting of EZ-C1 can be changed to another profile. Also, while the EZ-C1 is in operation, the profile in use can be saved.

The name of the currently selected profile is displayed in the title bar of EZ-C1.



CAUTION

- Device settings are common to all profiles. Therefore, a change made to the settings in the Configure | Devices tab causes update of device information in all profiles.

Note

- When the EZ-C1 starts, the profile selection dialog box appears, prompting you to select a profile.
- When the EZ-C1 exits, a prompt appears for saving the profile.

4.2.5.1 Save

The settings in the current ini file are overwritten for the selected profile.

4.2.5.2 Save as

The settings in the current ini file are saved as a new profile with a desired name.

4.2.5.3 Select

A list of profiles appears. The profile selected during starting of EZ-C1 can be changed to a different profile.

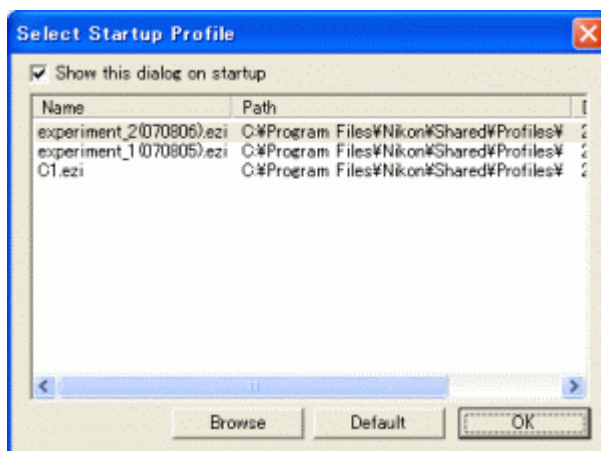

Figure 4.2-7 Select Startup Profile dialog box

Name	Function overview
Show up this dialog on startup	Shows or hides the profile selection dialog during starting of EZ-C1. When checked: Displays the profile selection dialog during starting of EZ-C1. When unchecked: Does not display the profile selection dialog during starting of EZ-C1.
[Browse]	Opens the file selection dialog box, allowing you to select an ezi file not shown in the list.
[Default]	Selects "C1.ezi".
[OK]	Applies the settings of the selected profile. As a result, the EZ-C1 is restarted.

4.2.6 Acquire Option

Select the Acquire Option command from the Configure menu to display the EZ-C1 Configure Acquire Option dialog box. Here you can set default settings for file names to be saved.

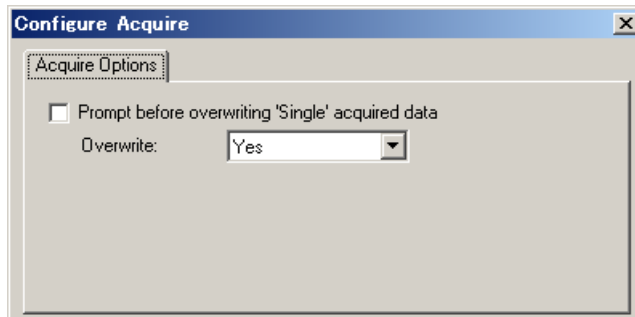

Figure 4.2-8 Configure Acquire Options dialog box

Name	Function Overview
Prompt before overwriting 'Single' acquired data	Select this check box to display the Overwrite confirmation dialog box before updating image data at the start of scanning or during image acquisition mode setup, etc. Deselect this check box to set the following options.
Overwrite	Select Yes to enable overwriting without prompting for confirmation with the Overwrite confirmation dialog box. Select No to disable overwriting. (The Overwrite confirmation dialog box is not displayed.)

4.3 Data

You can analyze and process images, write character strings on images, and draw diagrams on images by using the following commands in the Data menu of EZ-C1.

- Analyze | Distance (see 4.3.1.1)
- Analyze | Histogram (see 4.3.1.2)
- Analyze | Spectra (see 4.3.1.3)
- Annotate | Color Legend, Cross Hair, Ruler, Select, Spot, Text (see 4.3.2)
- Calculate | Ratio (see 4.3.3)
- Filter | Kirsch, Laplace, Low Pass, Median (see 4.3.4)
- Reduce | Bin (see 4.3.5.1)
- Reduce | Crop (see 4.3.5.2)
- Spot (see 4.3.6)
- Spot| | PolyLine (see 4.3.6.2)
- Volume | Volume Height (3 D images only) (see 4.3.7.1)
- Volume | Volume Render (3 D images only) (see 4.3.7.2)

4.3.1 Analyze

4.3.1.1 Distance

Crosshair: A cross-shaped cursor consisting of the intersection of a vertical and horizontal line.

Crosshair pair: A pair of crosshairs which are used together.

To measure a distance in the image, the “Analyze” – “Distance” command on the “Data” menu is available. This command adds one or more Cross hair pair to the views of the active image (Figure 4.3-1). In addition, the “Distance” tab shows up in the View Settings dialog box (see 3.6).

A Cross hair pair is used to select a position in the multi-dimensional image. To move the cross hair to the desired position, select it with the mouse left button. The selected state is indicated by small black handles. In the selected state, the cross hair is positioned by dragging it with the mouse left button. To move the cross hair in two dimensions simultaneously, start the dragging in the crossing point. When dragging is started on one of the lines, the position in one dimension is changed.

The distance can be measured in two modes: the absolute mode or the differential mode. In the absolute mode, only one cross hair pair is present and the distance is measured with respect to the image origin (left top corner). In the differential mode, two cross hair pairs are present: the reference cross hair pair and the running cross hair pair. The distance is measured between the two cross hair pairs.

In addition to positioning the selected cross hair with the mouse, the position can be set using the keyboard. First, the fields in the Distance tab can be used to set the position of the running cross hair pair. To modify the position of the other cross hair pair, press the [Swap] button which switches the reference cross hairs and running cross hairs. Then, the position of the selected cross hair can be modified using the following keystrokes.

- | | |
|-----------------------|--|
| <Left>, <Right>: | move in first dimension (usually X dimension). |
| <Up>, <Down>: | move in second dimension (usually Y dimension). |
| <PageUp>, <PageDown>: | move in third dimension (usually Z dimension or time). |
| <Home>, <End>: | move in fourth dimension (usually time). |
| <Delete>: | delete cross hair. |

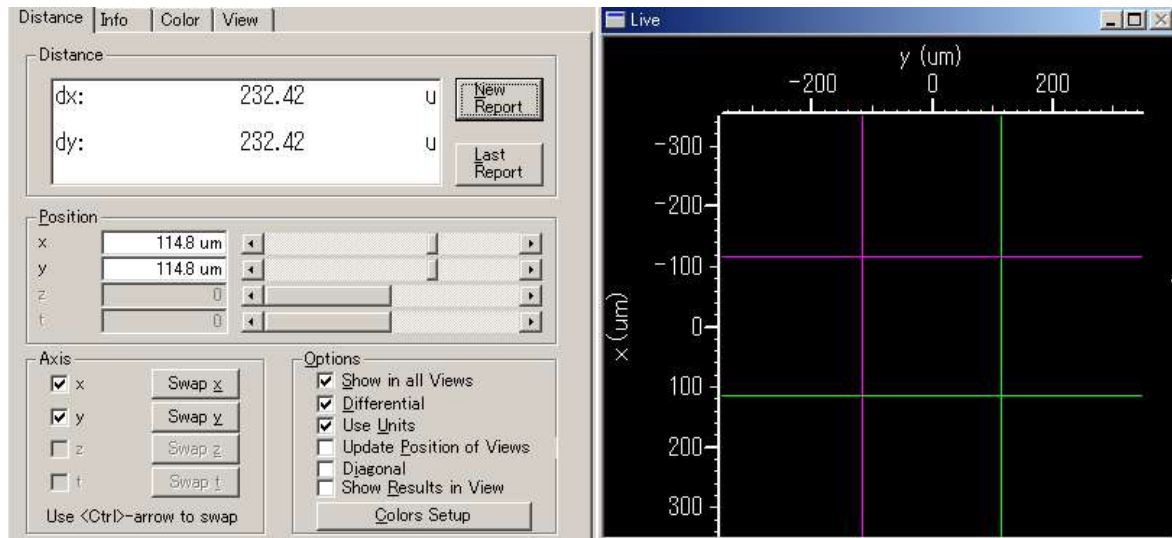



Figure 4.3-1 Distance tab and an image window with a two Cross Hair Pairs

The Distance tab contains the following control fields.

Name	Function Overview
Distance	
This field displays the distance between the reference cross hair crossing and the running cross hair.	
[New Report]	By pressing the [New Report] button, a new report document is created with the base name of the current image and the extension .txt. The distance measurements are added to the report in a tab-separated format. Comments can be added and the report can be saved under the default name or under a different name. When a report is opened, pressing the [Last Report] button will add the new measurements to the current report file.
[Last Report]	When the last used report is not closed, the measurements will be added. Otherwise a new report is created.
Position	
The position of the current running cross hair pair. After the position is changed, click on the image to update the cursor position on the image.	
Axis	
The crosshair pair to be displayed and the method used to make measurements can be selected in the box. The display changes as follows when each checkbox is checked.	
x	Display the lines to measure distances in the X direction and measured value is displayed in the "Distance" field.
y	Display the lines to measure distances in the Y direction and measured value is displayed in the "Distance" field.
z	Display the lines to measure distances in the Z direction and measured value is displayed in the "Distance" field.
t	Display the lines to measure distances in the T direction and measured value is displayed in the "Distance" field.

Swap	Check when swapping the reference crosshair pair for the running crosshair pair. The swap is made even if both cross hair pairs are clicked.
Options	
Show in all Views	Check this options to show the cross hairs in all views. Uncheck to show it only in the active view.
Differential	Check this options to show two cross hair pairs and report the distances relative to the reference cross hair. Uncheck to show only one crosshair and report the measurements with respect to the image origin.
Use Units	Set the Position indicator unit either μm or pixels.
Update Position of Views	When the crosshair is moved, update the view to show the part of the image that contains the cross hair crossing point. When in the "view" option "Synchronize position of other views" is also set, all views will move their position to show the cross hair crossing point. Note that when the reference and running crosshair are swapped, all positions will be changed to show the running cross hair crossing point.
Diagonal	Only the diagonal distance between crossing points is reported.
Show Results in View	Check this option to open another window to report the linear distance between points for each dimension. Make the window which is displaying the linear distance for the dimension shown active, and Use the Page Up or Page Down keys or the up or down (\uparrow , \downarrow) cursor keys to change. Note that the relative linear distance for each dimension is displayed when "Differential" is checked.
[Colors Setup]	Press this button to display the dialog box for setting the colors and line format. This dialog box can also be displayed by double clicking on part of the crosshair with the mouse.

4.3.1.2 Histogram

The “Analyze” – “Histogram” command on the “Data” menu creates a live histogram of the active image. The command is also available with the Histogram button  on the Data bar. The histogram is calculated by mapping the image pixel intensities to a bin index. When the source image or the histogram window is activated, on the View Settings dialog box (see 3.6), the Histogram tab (Figure 4.3-2) with the options for the histogram operation is added.

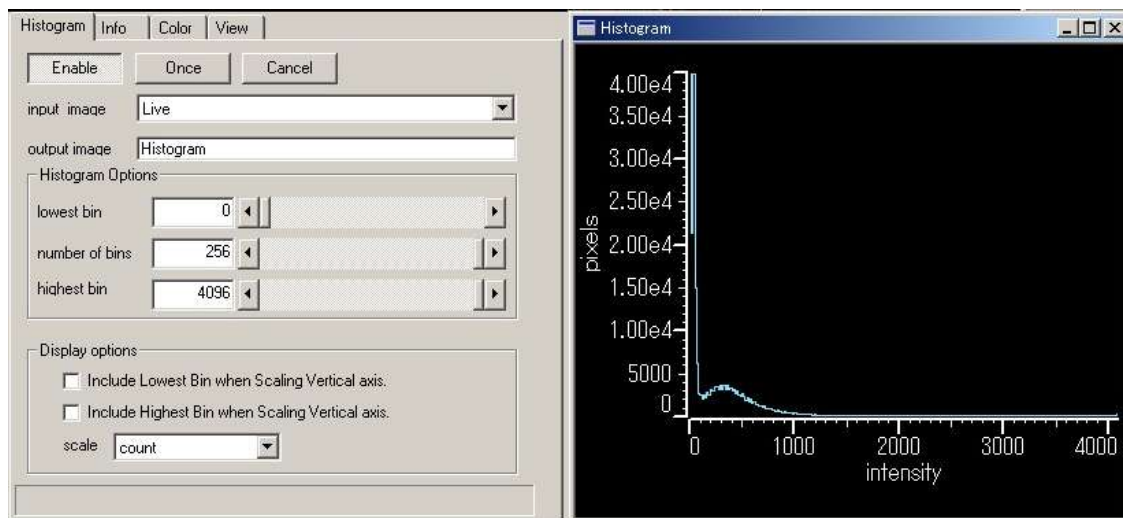



Figure 4.3-2 Histogram tab and a Histogram window

The histogram options on this tab are shown below.

Name	Function Overview
[Enable]	Press this button to start or stop the live calculation of the histogram.
[Once]	Press this button to calculate the histogram once.
[Cancel]	Press this button to stop the calculation and remove the Histogram tab. The window with the histogram graph will remain on the screen but the histogram will not be recalculated again. To close the window with the histogram graph, press the close button  on the caption bar or select the “Close” command on the “File” menu when the window is active.
input image	The name of the source image
output image	The name of the output image
lowest bin	The pixel intensity that is mapped to the lowest bin. The number of pixels with a pixel value lower than lowest bin is counted in the first bin. This bin count is shown as the first point of the histogram.
number of bins	The number of bins. This number determines the number of points in the graph. Reduce this number to segment the image into a smaller number of bins.
highest bin	The pixel intensity that is mapped to the highest bin. The number of pixels with a pixel value higher than highest bin is counted in the last bin. This bin count is shown as the last point of the graph.

Include Lowest Bin when Scaling Vertical axis	The vertical axis scaling is optimized after each calculation to show all points of the histogram. If this option is unchecked, the first point of the histogram is ignored, and may extend beyond the top of the graph. Uncheck this option if the image contains a large number of pixels with an intensity lower than lowest bin and you want to see the histogram of the intermediate pixels value at a smaller vertical scaling.
Include Highest Bin when Scaling Vertical axis	The vertical axis scaling is optimized after each calculation to show all points of the histogram. If this option is unchecked, the last point of the histogram is ignored, and may extend beyond the top of the graph. Uncheck this option if the image contains a large number of pixels with an intensity higher than highest bin and you want to see the histogram of the intermediate pixels value at a smaller vertical scaling.
scale	The scale of the vertical axis can be selected.
count	The number of pixels in a bin.
pro mille	The relative number of pixels in a bin with respect to the total number of pixels in 1/1000 units.
units	The calibration factors are used to calculate the physical area of volume that is covered by the pixels in the bin. In 2-dimensional images, the vertical axis shows the area covered by the pixels, for 3-dimensional images, the vertical axis shows the volume taken in by the pixels in each bin.

4.3.1.3 Spectra

Use the Analyze | Spectra command from the Data menu to open the Data Series graph window for active windows. This command can also be accessed using the Data Series button  on the Annotate bar. The graph window shows wavelength graphs for spots set in active images.

A detailed description is given in Section 4.7, "Data Series."

4.3.2 Annotate/ Annotate bar

The commands on the “Data” menu and buttons on the Annotate bar enable the following features.

CAUTION

- If the “Steps” in the scan settings (see 3.4.4) is changed, the drawing and text are not displayed on the specified position. Please set the position again.

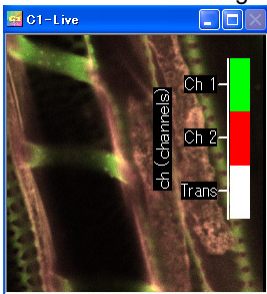
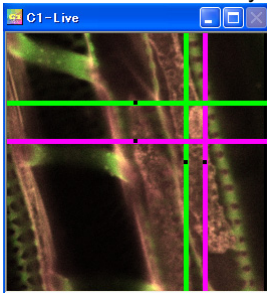
Name	Function Overview
Color Legend	<p>Creates a color scale in the image. This scale shows the relationship between display color and pixel values.</p> <p>When displayed in the Single Channel Pseudo Color mode, it uses colors from the lookup table to render Intensity display colors.</p> <p>The Multi Channel Pseudo Color and the Multi Channel True Color mode use the display colors of each channel to show images.</p> 
Cross Hair	<p>Creates a distance measuring cross hair (see 4.3.1.1) in the image. Double click on the cross hair, or click the Color Setup button, to display a dialog box to set the color and line format. Press the <Delete> key to remove the cross hairs.</p> 

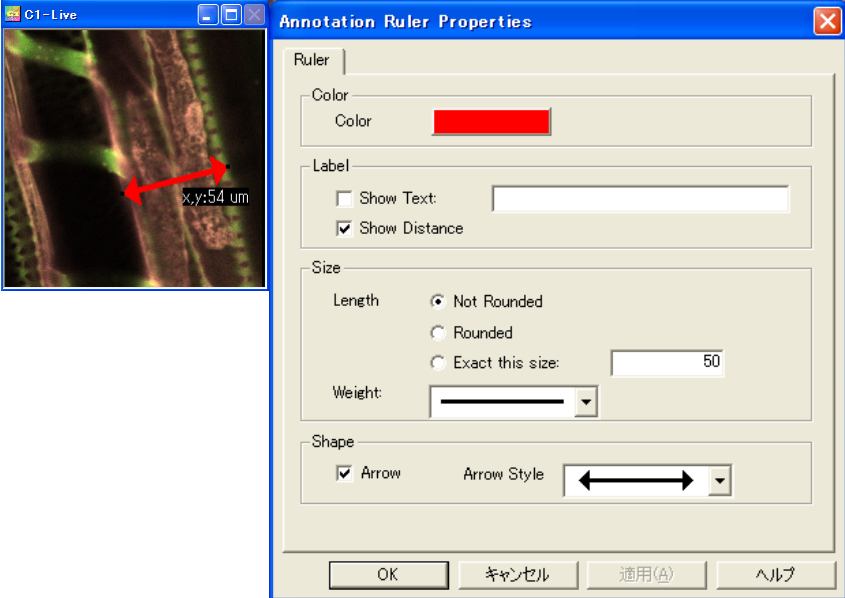
<p>Ruler</p>	<p>Click the left mouse button on an image while dragging, to create a ruler object. The ruler is a white rectangular bar to which a length-indicating label is attached. To delete any ruler, select the ruler, and then press the Delete key. Double-clicking a ruler you've created brings up the Annotation Ruler Properties dialog box (Figure 4.3-3).</p>  <p>Figure 4.3-3 Annotation Ruler Properties dialog box</p> <p>Color Color: Specify a color of a ruler.</p> <p>Label show Text: A text comment is displayed on a ruler. Show Distance: A length of a ruler is displayed.</p> <p>Size Not Rounded: Ruler length is displayed with a value not rounded. Rounded: Ruler length is not rounded off. Set values are expressed in multiples and rounded to the nearest representable multiple. (Enter only representable values such as 5 um, 10 um, 20 um, etc. for rounded values.) Exact this size: Enter ruler length values in the edit box. Weight: Specify a thickness of a ruler.</p> <p>Shape Arrow: An arrow for a ruler is displayed. Arrow Style: Specify a type of a ruler.</p> <p>! To obtain an exact scale, make sure that settings of Configure Objectives (see 4.2.3) are made correctly, and that Calibration on the Mirrors tab of the Configure Confocal C1 dialog box (see 5.2.4) are set correctly.</p>
<p>Select</p>	<p>Selects an annotated object displayed on the image to permit movement or size adjustments.</p>

Text	Left-click on an image to display the Annotation Text Properties dialog box and enter text for annotation. To modify an existing text annotation, double-click on the text object in the image and revise the content in the ensuing Annotation Text Properties dialog box. Press the Delete key to discard the text annotation.
-------------	--







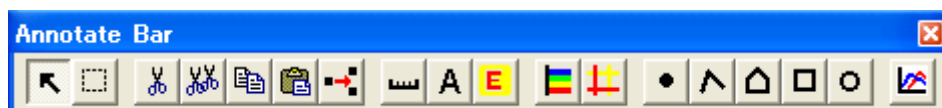

4.3.2.1 Annotate Bar









Shortcut buttons for the Annotate function are provided on the Annotate Bar.

This bar is a part of the tool dialog box and can be displayed with the Annotate Bar command on the Tool menu.

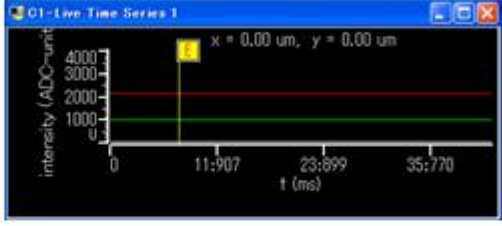
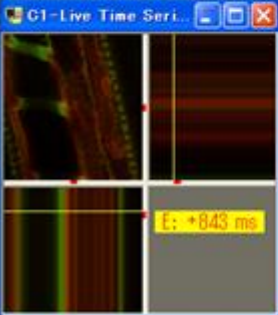
Following functions are available with this bar.



Name	Function Overview
 Select	Press this button to select an annotation object on the image to move it or to resize it. (Same as Select on Annotate of Data menu)
 Lasso	Selects multiple spots. Selects all spots within the specified area.
 Cut	Deletes the selected figure or character.
 CutAll	Deletes all figures or characters.
 Copy	Copies the selected figure or character (excluding CrossHair).
 Paste	Pastes the copied annotation onto the active window. When pasting to a different window, the XY coordinate will be inherited.
 Duplicate	Duplicates the selected annotation within the same window.
 Ruler	Press this button to display a ruler. (Same as Ruler on Annotate of Data menu)
 Text	Press this button to enter an annotation text on the image. (Same as Text on Annotate of Data menu)

<p> Event marker (ATE)</p>	<p>Specify the ATE marker  (acquisition time event marker), which is one of time event markers.</p> <p>This marker targets only the Time Series data after the observation and is used to set an event in the acquired data.</p> <p>Clicking this button displays a difference from the time at which frame data acquisition starts” for each frame based on “the time, for which a marker is set, at which frame data acquisition starts.</p> <p>(See 3.5.6 Time Series.)</p> <p>Display in 2D image Acquisition start time for each frame is displayed. It is based on a frame for which an event is set.</p>  <p>Display in 1D Graph Data acquisition start time for a frame for which an event is set is displayed. (Figure below shows the case when Axis = t.)</p>  <p>Display in 3D orthogonal Data acquisition start time for a frame for which an event is set is displayed.</p>  <p>Display in 3D tiled A frame for which an event is set is displayed.</p> 
<p> Color Legend</p>	<p>Press this button to display a color scale. (Same as Color Legend on Annotate of Data menu)</p>
<p> Cross Hair</p>	<p>Press this button to display a cross hair for measurement of an image. (Same as Cross Hair on Annotate of Data menu)</p>
<p></p>	<p>Information on these buttons is provided in Section 4.3.6, “Spot” on the Spot command.</p>
<p></p>	<p>Information on this button is provided in the description on Data Series (see 4.7).</p>

4.3.3 Calculate (Ratio)

The “Ratio” command on the “Data” menu makes it possible to calculate the ratio of 2 channels in a currently active image in real time. The ratio is found by dividing one channel (numerator) by another channel (denominator). Enter settings in the Ratio tab (Figure 4.3-4) in the View Settings dialog box.

You can also run the “Ratio” command by pressing the Ratio button  on the Data bar.

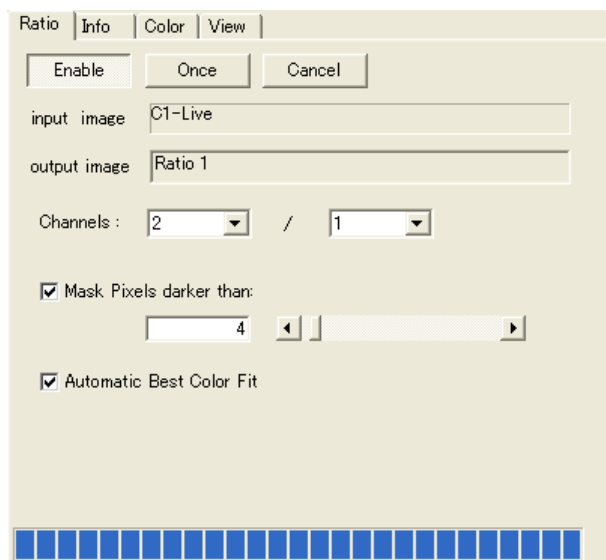



Figure 4.3-4 Ratio tab

The filter options on this tab are shown below.

Name	Function Overview
[Enable]	Press this button to start calculation of image ratios. A second press cancels the operation.
[Once]	Press this button to calculate the image ratio once and create a Ratio image.
[Cancel]	Press this button to stop calculation and close the Ratio tab. The Ratio window will still be on the screen, but the Ratio image is not recalculated. To close the Ratio window press the Close button  or select the “Close” command from the “File” menu.
input image	Show the window name of the image to be calculated.
output image	Show the name of the window displaying the calculation result.
Channels	Specify the channels to be used as numerator and denominator in the calculation of image data.
Mask Pixels darker than	Low pixel values in the divider channel result in very high ratio values. Check the “Mask Pixels darker than” to set ratios to zero when the divider channel pixel value is lower than the specified threshold.
Automatic Best Color Fit	Check this option to perform the “Best Intensity Fit” operation after each calculation (same operation is obtained when  button on the Color tab of the View Settings dialog box (see 3.6.2).

4.3.4 Filter

The “Filter” commands on the “Data” menu, Median, Low Pass, Kirsch and Laplace, start live filtering of the active window. The commands are also available with the Median **M** and the Low Pass **LP** buttons on the Data bar. When the filtered or source image is activated, the View Settings dialog box shows the Filter tab (Figure 4.3-5) with the options for the filter operation.

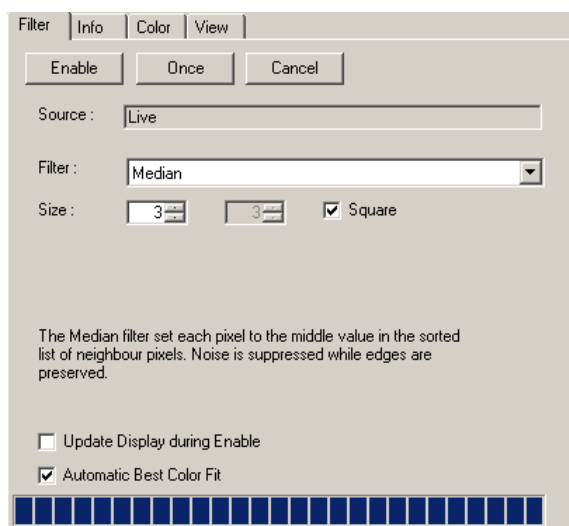



Figure 4.3-5 Filter tab

The filter options on this tab are shown below.

Name	Function Overview
[Enable]	Press this button to start or stop live filtering of the image.
[Once]	Press this button to filter the image once.
[Cancel]	Press this button to stop the calculation and remove the Filter tab. The window with the filtered image will remain on the screen but is not recalculated again. To close the window with the filtered image, press the close button ✕ on the caption bar or select the “Close” command on the “File” menu when the window is active.
Source	Shows the name of the source image.
Filter	Specifies the filter to be used. Filters which can currently be used are: the Kirsch filter, Laplace filter, Low Pass filter, and Median filter.
Kirsch filter	Enhances the gradient. Check the “Gradients Only” option to display only gradients.
Laplace filter	Enhances edges. Check the “Edges Only” option to display only edges
Low Pass filter	The average value for adjacent pixels is set one-by-one for each pixel. Although this eliminates noise, it also lowers brightness.
Median filter	The median value for a sorted list of pixels that touch is set one-by-one for each pixel. Although this eliminates noise, edges are saved.

Size	Set the size of the Filter window in the horizontal and vertical direction. A larger filter window has more impact but increases the calculation time.
Square	Check this option to force the Filter window to be square.
Power	It is possible to increase or decrease the brightness of the processed edge image or gradient image. (This item can only be checked when the Kirsch or Laplace filter is selected.)
Brightness	It is possible to increase or decrease the brightness of the original image with which a gradient or edge image is to be merged. (This item can only be checked when the Kirsch or Laplace filter is selected.)
Gradient Only	Check this option to display only the processed gradient image. If unchecked, the gradient image is merged with the original image. (This item can only be checked when the Kirsch filter is selected.)
Edges Only	Check this option to display only the processed edge image. If unchecked, the edge image is merged with the original image. (This item can only be checked when the Laplace filter is selected.)
Circular Filter	Check this option to change the shape of the filter kernel from a square shape to a circular shape. Doing this alleviates the noise produced due to processing regularly associated with the grid pattern. (This item can only be checked when the Low filter is selected.)
Update Display during Enable	Check this option to refresh the image during the calculation of the image. This will slow down the calculation time but gives you visual feedback about the progress.
Automatic Best Color Fit	Check this option to perform the “Best Intensity Fit” operation after each calculation (same operation is obtained when  button on the Color tab of the View Settings dialog box (see 3.6.2).

4.3.5 Reduce

4.3.5.1 Bin

Selecting the “Bin” from the Reduce command in the Data menu adds a Binning tab (Figure 4.3-6) to the View Settings dialog box (see 3.6). This tab lets you alter the resolution by adding the brightness values of several pixels (or pixels between two frames) and representing the sum by one pixel (or pixels between two frames). Use this function to reduce image size or increase brightness. (This increases the intensity of all pixels, thereby increasing the value of any particular pixel.)

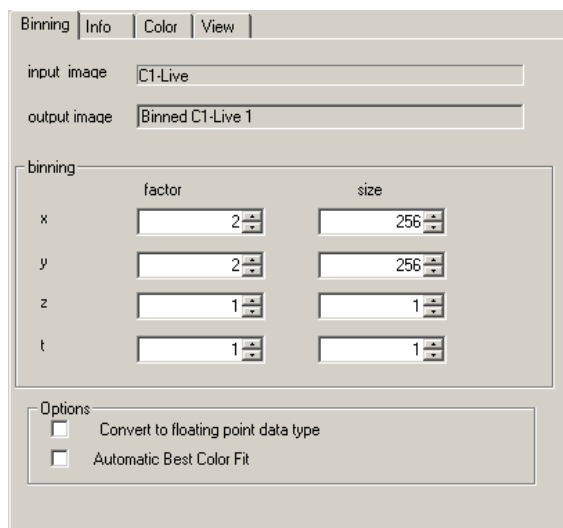



Figure 4.3-6 Binning tab

Name	Function Overview
input image	Shows the window name in which the original image whose resolution you are going to alter is displayed.
output image	Shows the window name in which the image with adjusted resolution is displayed.
binning	
factor	Specify (or show) the number of pixels (or frames) you want to be calculated as one set.
size	Specify (or show) the pixel size (or number of frames) that you want after the size is altered.

Options	
Convert to floating point data type	When this option is selected, the data type in which the calculated total brightness value will be stored is changed to four-byte floating-point values. Unless this option is selected, the data type of the original data is used. - In cases in which the original data is an 8-bit quantity, if brightness values 150 and 200, for example, are added together, the sum will exceed the maximum value representable by 8 bits (= 255). Unless four-byte float option is selected, the summed value cannot be stored in the original data type and is simply replaced by the greater of the two pixel values. Selecting this option enables storage of the entire calculated value.
Automatic Best Color Fit	When this option is selected, each time calculation is completed, the same operation is performed as would be performed when you pressed the optimum brightness set button  on the Color tab of the View Settings dialog box (see 3.6.2).

4.3.5.2 Crop

The “Crop” command on the “Data” menu can be used to create a sub-image of the current image. The command is also available with the Crop button  on the Data tool bar. The sub-image contains a part of the active image. Create a cropping area if you want to use only a part of the active image. The sub-image can be used as a normal image. However, changes in the sub-image will also show up in the original image.

Create a cropping area if you want to:
View a part of the original at a larger detail.
Save only a part of the original image.
Use only a part of the original image for data analysis.

When a cropping area is created, the source image window, a cropping area tracking box appears in the source image window to specify the cropped area. Press the mouse left button in the cropping area tracking box and move the box to set the position. Press the mouse left button on one of the black handles to resize the cropping area.

The Cropping Area tab (Figure 4.3-7) is added to the View Settings dialog box (see 3.6) to enter the cropping area position and size.

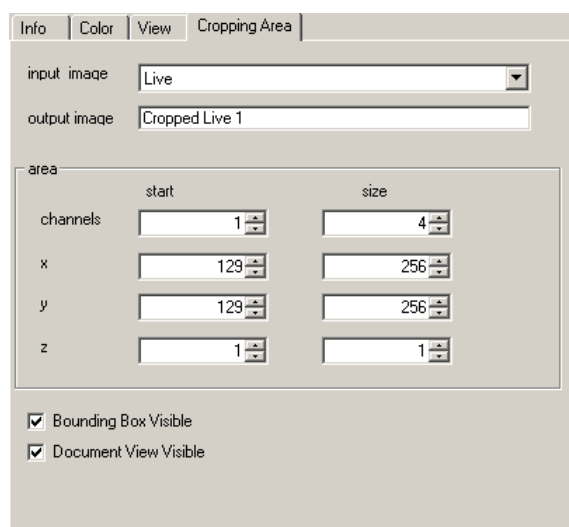

Figure 4.3-7 The Cropping Area tab

The Cropping Area tab contains the following items.

Name	Function Overview
input image	The name of the input image.
output image	The name of the cropping area.
area	
start	Sets the coordinate of the first pixel of the cropping area as well as the number of channel.
size	Sets the number of x, y, and z pixels in the cropping area as well as the number of channel.
channels	The index of the first color band (start) and the number of color bands in the cropping area (size). To refer only to the first color band, set the "start" of the "channel" to 1 and the "size" to 1. To refer only to the second color band, set the channels offset to 2 and the size to 1. For each dimension in the input image, the above two fields (starts, size) are provided.
Bounding Box Visible	Check this option to show the area to be cropped in the currently active image window.
Document View Visible	Uncheck this box to hide the window that shows the cropping image.



4.3.6 Spot



4.3.6.1 Spot

Using a command in Spot on the Data menu or icon button on the Annotate bar, draw a spot in the two or more dimensional image. Then information inside the spot can be obtained. Spots can also be used as a border for Bleach operations (See 3.7).

The Spots Of Interest tab in the View Settings dialog box allows you to obtain Intensity information and show Intensity graphs whose horizontal axis is t and z.

The "Spot" command and the icon buttons on the Annotate bar can draw the following type of spots.

Name	Function Overview
Ellipse (Annotate Bar: )	Creates an elliptical spot. When dragging a mouse from the clicked point, a diameter becomes larger. Create a spot while holding down the Shift key to draw a circular spot.
Point (Annotate Bar: )	Click a point spot. A spot is created at the point clicked. Information can be acquired from a single pixel or bleach setting can be performed by this button.
Polygon (Annotate Bar: )	Creates a polygonal spot. Click to create vertexes. Double-click at the end point to draw a line between the starting point and the end point, which automatically makes a polygon.

<p>PolyLine (Annotate Bar: )</p>	<p>Creates a free polygonal line. Click to create vertexes. Double-click at the end point. (See 4.3.6.2.)</p> <p>! This spot can be used for spectral graph display and the Bleach function like other spots. The spot also has length measurement and Intensity Profile functions.</p>
<p>Rectangle (Annotate Bar: )</p>	<p>Left-click to form the starting point and hold down the button while moving the mouse to the end point where you let go of it. The starting point and end point form the diagonally opposite corners of the rectangle that is drawn.</p>

Note

- The above spots can be displayed only in 2D display mode (when View = 2D image and Axis = xy, yx are set in the View Settings dialog box).
- The square handles at the boundaries of a spot can be dragged to resize it. To change the location of a spot, click a point inside the spot or on the boundary and drag. To delete a selected spot, press the Delete key.

The Spots Of Interest tab (Figure 4.3-8) in the View Settings dialog box appears when a spot is drawn. This tab provides the following information and the following settings.

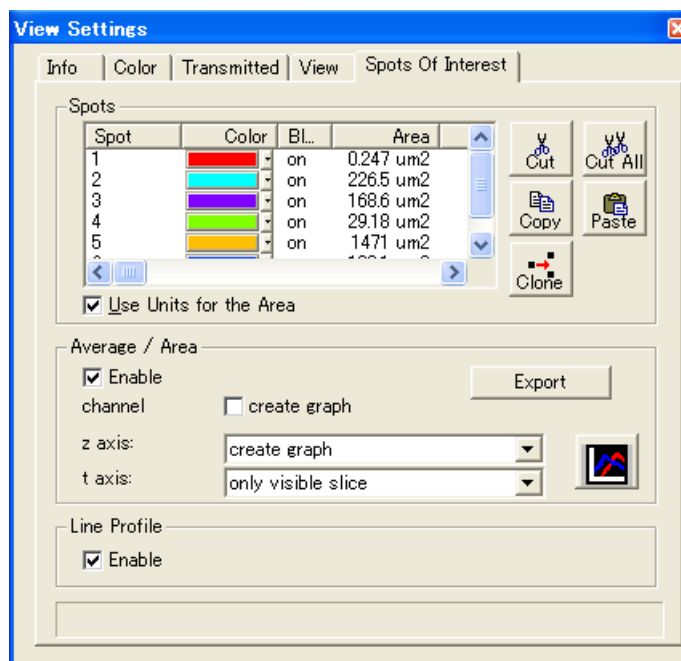





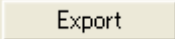



Figure 4.3-8 Spots Of Interest tab

Name	Function Overview
<p>Spots Display the Spot data.</p>	
<p>Spot</p>	<p>Display the spot name. Serial numbers are assigned by default.</p> <p>! Right-click Spot in the target window to open the Property page to change the name of a spot.</p>

Color	Select colors for spots. ! The color selected for a spot is also used in the Data Series graph window.
Bleach	Specify on when the spot is bleached. ! Bleach is only available if the PC is equipped with an analog output board (a board installed in a PC for controlling laser output).
Area	Show the area occupied by a spot.
< >:n	Indicate the average brightness of each channel.
 [Cut]	Delete the selected spot in a window.
 [Cut All]	Delete all spots in a window.
 [Copy]	Copy the selected spot.
 [Paste]	Pastes the copied spot.
 [Duplicate]	Duplicates the selected spot within the same window.
Use Units for the Area	Switch area indicator units. When this checkbox is selected, areas are indicated in $\mu\text{m} \times \mu\text{m}$; when deselected, areas are indicated in pixels \times pixels.
Average/Area Specify the brightness data of the spot.	
<input checked="" type="checkbox"/> Enable [Enable]	Area, < >:n and output graph values are recalculated during scanning and spot movement (and resizing) while this checkbox is checked.
channel <input checked="" type="checkbox"/> create graph	When this checkbox is checked, the spectral graph for the spot data of the spectrum image is displayed. (The horizontal axis is wavelength.)

* axis	<p>Appears only for a window with 3D data or data with more dimensions (Z-stack or TimeSeries data). This item is not available for 2D data.</p> <p>! This axis is referred to as the z-axis for Z-stack data and as the t-axis for TimeSeries data.</p> <p>only visible slice: An area and average brightness value of each spot on the displayed 2D slice are calculated.</p> <p>create graph: For each spot an average intensity value graph whose horizontal axis is t or z is created. (The [z/t-axis graph] button provides the same function.)</p> <p>integrate over full range: Volumes of each spot and the brightness values of all slices of each spot are integrated. And an average value of them is displayed.</p>
 [Export]	<p>Spot information (areas (pixel,um2) and a brightness value of each channel) is output in the txt file with the csv format. A pass and filename of the output file can be specified.</p> <p>When target data is 3D or 4D, contents of the output file depend on settings of "z-axis and t-axis."</p> <p>Example: when "z = create graph" and "t = only visible slice":</p> <pre>Z1, Spot 1, Area[pixel], Area[um2], Intensity(Ch1), Intensity(Ch2) .. Z1, Spot 2, Area[pixel], Area[um2], Intensity(Ch1), Intensity(Ch2) .. Z1, Spot 3, Area[pixel], Area[um2], Intensity(Ch1), Intensity(Ch2) .. Z2, Spot 1, Area[pixel], Area[um2], Intensity(Ch1), Intensity(Ch2) .. Z2, Spot 2, Area[pixel], Area[um2], Intensity(Ch1), Intensity(Ch2)</pre>
 [t/z axis graph]	<p>Press this button to display a time series graph or Z-stack graph of the spot data in 3D images (an average intensity value graph whose horizontal axis is t or z).</p> <p>! This button is active when "create graph" is selected in *axis.</p>
<p>Line Profile Specify the Intensity Profile function when the Spot is made of PolyLines.</p>	
<input checked="" type="checkbox"/> Enable [Enable]	<p>Check this checkbox to display an Intensity Profile graph for a spot made of PolyLnes.</p>

Note

- Spots are drawn according to the following rules.
 - (1) A spot drawn on an image created using the New command on the Window menu also appears in existing windows in different modes, but does not appear on original images in the same mode, in other new windows in the same mode and in new windows belonging to other groups.
 - (2) A spot drawn in an existing window created using the New command on the Window menu also appears in existing windows in different modes, but not in new windows of the same mode and new windows belonging to a different group.
- Example: Open a Live window and a TimeSeries window and create a new window in each.
- (1) Drawing a spot in a live window
 - The same spot is also drawn in the TimeSeries window, but not in the new windows of either mode.
 - (2) Drawing a spot in new window in Live mode
 - The same spot is also drawn in the TimeSeries mode, but not in the Live window and other new windows.

4.3.6.2 PolyLine

Select the PolyLine command from “Spot” on the “Data” menu or icon button on the Annotate bar to draw a PolyLine on a 2D or 3D image to obtain information of the line.

Like other type spots, this spot has Intensity data (graph display), the Bleach function as well as length measurement and Intensity Profile functions.

Length measurement function: When a PolyLine is drawn, length measurement data is also displayed with a solid line. The unit of the measurement data can be changed by using “UseUnits” on the View tab in the View Settings dialog box. Right-click PolyLine to display the Spot Properties dialog box, where a width and color of a line can be changed. (See Figure 4.3-10 Spot Properties dialog box.)

Intensity Profile function: When “Line Profile” is enabled on the Spots Of Interest tab in the View Settings dialog box, Intensity Profile graphs are displayed (see Figure 4.3-9 Intensity Profile graph). Display setting can be changed on the View tab in the View Settings dialog box. (See 3.6.3.6.)

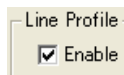
**Spot functions**

Bleach function: PolyLine can be specified as “Bleach border” by setting the Bleach function like other type spots. The setting is made on the Spots Of Interest tab in the View Settings dialog box or in the Spot Properties dialog box displayed by right-clicking PolyLine.

Intensity data (graph display): Like other type spots, intensity data is displayed on the Spots Of Interest tab in the View Settings dialog box. When image data is 3D or spectral data, “an Intensity graph of PolyLine whose horizontal axis is t or z” or a “spectral graph” can be displayed.

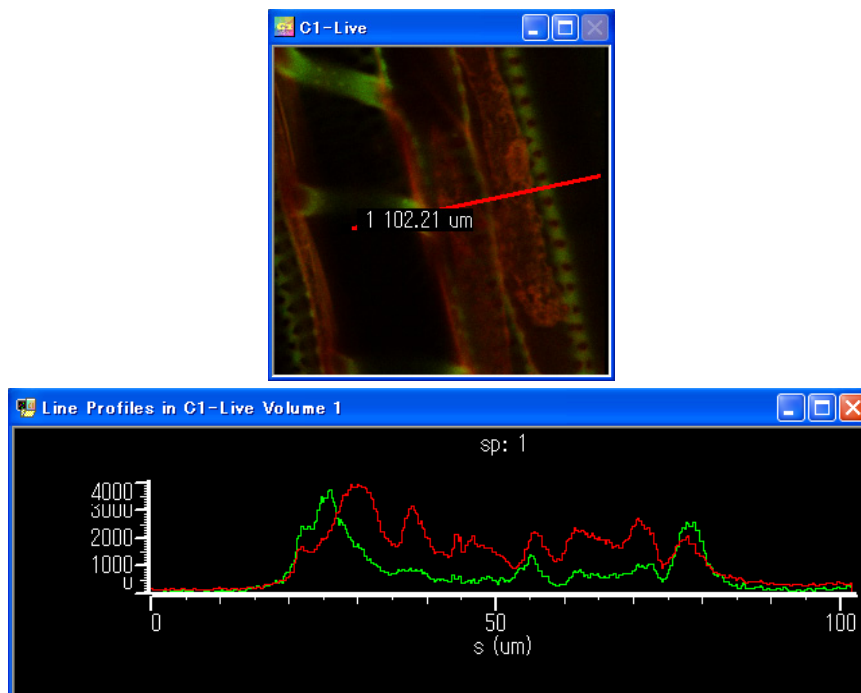

Figure 4.3-9 Intensity Profile graph

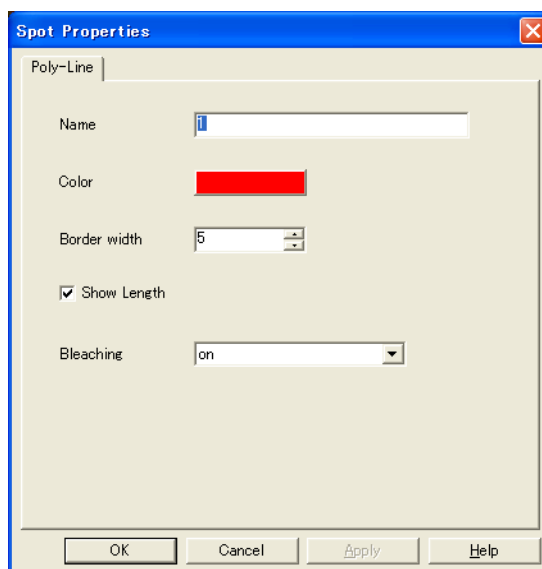

Figure 4.3-10 Spot Properties dialog box

Name	Function Overview
Name	Specify the Spot number. The default value is named after other spots.
Color	Specify the display color of spots.
Border width	Specify the thickness of lines. Between 1 to 2,048 pixels can be set.
Show Length	Check this checkbox to show the measured data.
Bleaching	Specify "on" to bleach the spot.

4.3.7 Volume

4.3.7.1 Volume Height

The “Volume” - “Volume Height” command on the “Data” menu creates a live height map of a 3D image. Each pixel in the height map represents the height position of the pixel in the stack with the highest intensity. When the source image or the height tab window is activated, the Volume Height tab (Figure 4.3-11) is added on the View Settings dialog box with the options for the volume height operation.

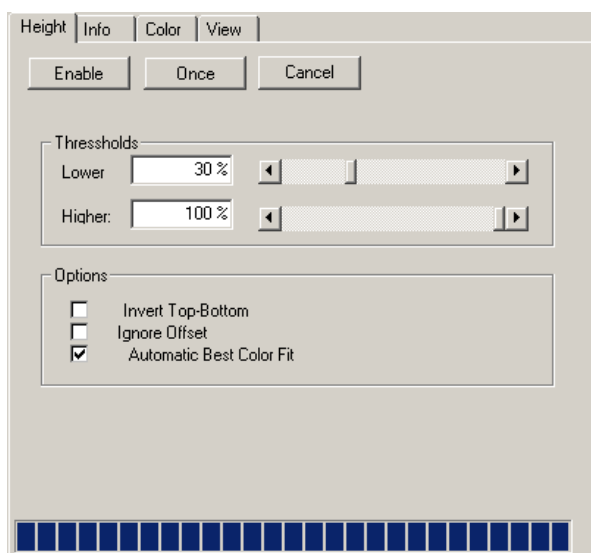



Figure 4.3-11 Volume Height tab

The volume height options on this tab are shown below.

Name	Function Overview
[Enable]	Press this button to start or stop the live calculation of the height map.
[Once]	Press this button to recalculate the height map once.
[Cancel]	Press this button to stop the calculation and remove the Volume Height tab. The window with the height map image will remain on the screen but the height map will not be recalculated again. To close the window with the height map window, press the close button  on caption bar or select the “Close” command on the “File” menu when the window is active.
Thresholds	Select the intensities thresholds used to calculate the height map. These fields specify a threshold value relative to the highest intensity found in the source image. Set the “Lower” to ignore lower intensities. Increasing the “Lower” threshold will suppress noise in areas were no maximum is found. Set the “Higher” threshold to ignore higher intensities. Decrease the “Higher” threshold to minimize the effect of noise in the brighter parts of the images.

Options	<p>The “Invert Top-Bottom” option will traverse the image in the opposite direction. Use this option to visualize details that are hidden by structures on topside of the image. The “Ignore Offset” option will ignore the offset info field and assign pixels height value with respect to the top of the image. The “Automatic Best Color Fit” option will perform the same effect as clicking the Best Color Fit button  (see 3.6.2) after each calculation.</p>
----------------	---

4.3.7.2 Volume Render

The “Volume” - “Volume Render” command on the “Data” menu creates a 3-dimensional object based on a given 2D image. To create a new projection, activate a 3D image and select the “Volume” - “Volume Render” command on the “Data.” A new 2D image is created. When the new image is activated, the Render tab (Figure 4.3-12) is added on the View Settings dialog box (see 3.6).

A cube wire-frame is drawn in the new image that represents the boundaries of the input image. The cube can be positioned with the mouse to the desired rotation angles. Press and move the mouse left button. A horizontal movement adjusts the spin angle. A vertical movement adjusts the tumble angle. Resizing the output window will change the number of pixels of the output image. Note that projecting the volume to a large 2D-image will require considerably more calculation time.

When the output image is saturated or too weak, press the  button to optimize the View Color Settings (see 3.6.2). The controls on this tab sheet can be used for manual adjustment of the color display properties of the new image.

The sequence controls are used to create an animated rotation. The output images size will be changed to a series of images that can be animated by pressing the  button on the View tab in the View Settings dialog box (see 3.6.3). In addition the images can be viewed in a tiled fashion by selecting the Tiled display mode.

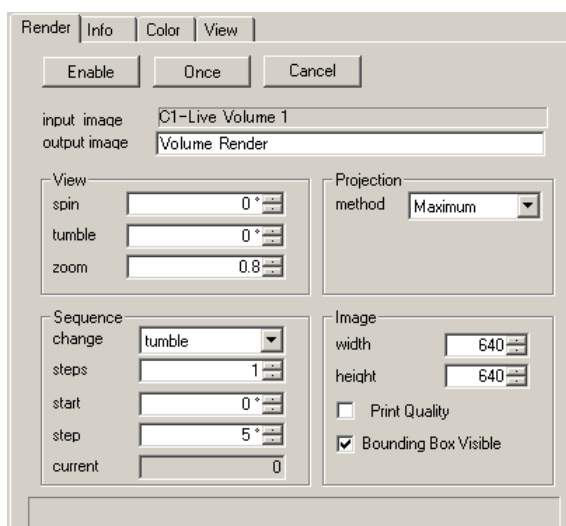

Figure 4.3-12 Render tab

The Render tab contains the following controls.

Name	Function Overview
[Enable]	Press this button to start or stop the render. When rendering is enabled, the arrival of new data in the source image will trigger recalculation.

[Once]	Press this button to perform the rendering once. The arrival of new data in the source image will not trigger recalculation.
[Cancel]	Press this button to remove the render module. The rendered image will stay in memory and can be saved to disk.
input image	The name of the 3D image used as input.
output image	The name of the output image.
View	
spin	The rotation angle around the y-axis. This angle can also be set using the mouse. Press the left button in the output image window and drag horizontally.
tumble	The rotation angle around the x-axis. This angle can also be set using the mouse. Press the left button in the output image window and drag vertically.
zoom	The zoom factor. Increase to zoom in to the center of the 3D image.
Projection	
Maximum	Maximum Intensity Projection processing is carried out. In this method, a intensity value is extracted only at the brightest point. The dynamic range in this method becomes the same as the range of one sheet of the images. For example, in the case of the image acquired by C1, the dynamic range of Volume Render is set to 4096.
Accumulate	Accumulate Intensity Projection processing carried out. In this method, calculation of addition etc. is performed about the intensity value in all points. In this case, the more it is far, the more an intensity value is calculated by a value decreasing. In this method, since addition processing is carried out, a dynamic range changes with the height of the acquired image data, width, and depth. For example, in the case of the data acquired by C1, if image size is 256x256 and Z step is 64, the dynamic range of Volume Render will be set to 4096x256. - Since there is the above-mentioned feature, in Volume Render image, both the setting value of "Coarse Saturation Level" and "Coarse Dark Level" does not have restriction.
Sequence	
steps	The number of images in the sequence.
change	The angle that is changed in the animation: spin or tumble.
start	The start value of the angle that is changed in degrees.
step	The increment step of the angle that is changed in degrees.
current	This number indicates which number in a sequence of images the current image corresponds to.
Image	

channels	The number of image channels of the output image.
width	The width of the output image in pixels. Resizing the output window changes the width.
height	The height of the output image in lines. Resizing the output window changes the height.
Print Quality	Check this option to perform Render calculations based on the same resolution as the original image. If this is unchecked, the Render calculation uses the image resolution needed to fit the image in the window (Volume Render window) in which the result will be displayed. - Use this function for high-resolution results: e.g., for printing.
Bounding Box Visible	Check this option to show the wire-frame of the input image boundaries in the output image.

4.3.8 Data bar

The Data bar contains shortcut buttons to access the Data menu commands. The Data bar is one of the tool dialog box (see 4.8) that can be displayed with the EZ-C1 "Data" on the "Tools" menu. The Data bar contains the following buttons.

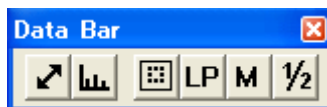

Name	Function Overview
	Measures a distance in the active image (see 4.3.1.1).
	Creates a live histogram of the active image (see 4.3.1.2).
	Creates a Cropping area of the active image (see 4.3.5.2).
	Creates a live image that is filtered with median filters from the active image (see 4.3.4).
	Creates a live image that is filtered with low pass filters from the active image (see 4.3.4).
	Creates a live ratio between two channels of the active image (see 4.3.3).

4.4 Launcher

The Launcher function lets you launch any other application from within EZ-C1. Select Settings from the Launcher to display the Launcher Settings dialog box (Figure 4.4-1). In this dialog box, you can register, edit, or delete information about the application you want to launch.

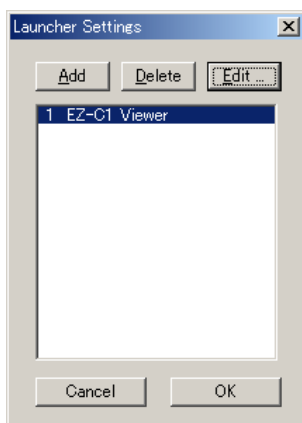

Figure 4.4-1 Launcher Settings dialog box

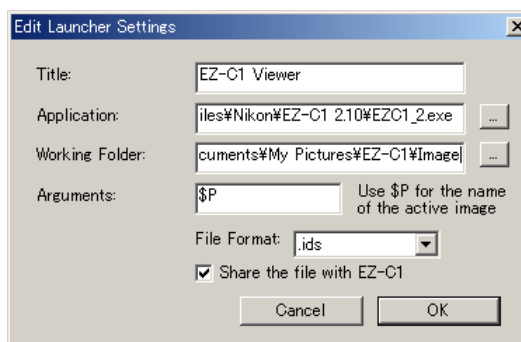

Figure 4.4-2 Edit Launcher Settings dialog box

The Launcher Settings and Edit Launcher Settings dialog box provides the following buttons.

Name	Function Overview
[Add]	Displays the Edit Launcher Settings dialog box (Figure 4.4-2). Use this button when you register a new application you want to launch.
[Delete]	Deletes a selected registration.
[Edit]	Displays the Edit Launcher Settings dialog box (Figure 4.4-2). The content of a selected registration can be edited. In the Edit Launcher Settings dialog box, you can set the following content.
Title	Enter the name of a registration. The registration name is displayed in the list of the Launcher Settings dialog box and below Settings on the Launcher menu. (The registration names are displayed in the order in which they were registered.)
Application	Set the directory in which the executable file for the application you want to launch is stored.
Working Folder	Specify the folder normally used by the application you want to launch.
Arguments	Specify the arguments that will be used in the application you want to launch. When you enter "\$P" here, the image in the image window selected in EZ-C1 is passed to the application at startup.
File Format	Specify the image format in which you want the image in the image window selected in EZ-C1 to be passed to the application as it starts. (This format can be specified only when "\$P" is set for Arguments.)

<p>Share the file with EZ-C1</p>	<p>The default file attribute setting does not allow the file to be simultaneously read from different applications.</p> <p>If this option is checked, EZ-C1 disables the attribute for the image file currently displayed in the selected EZ-C1 window, permits access to this file, and launches the registered applications.</p> <p>If this option is unchecked, EZ-C1 copies the image file currently displayed in the selected EZ-C1 window, permits access to the copy, and launches the registered application.</p>
---	--

Note

- "Share the file with EZ-C1" option can be changed only when IDS file format is selected. The option is automatically selected and cannot be unselected if any other file format is selected.

The application names registered in the Launcher Settings dialog box are added below Settings command in the Launcher menu. Click an application name to launch.

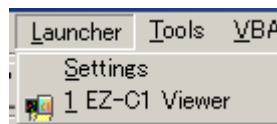

Figure 4.4-3

4.5 Macro

4.5.1 Channel Tiled / Untiled

Channel Tiled shows channel images in Tiled view. The channels for the target image is shown in Tiled view. Channel Untiled returns channel images shown in Tiled view to single frame images.

4.5.2 Ids Tiff Convert (Ids Tiff Convert Macro)

IdsTiffConvert converts an ids file into a tiff file continuously.

4.5.2.1 Starting Ids Tiff Convert

IdsTiffConvert is located in the default project (Default.ezm).

To start IdsTiffConvert, follow the procedure given below:

1. Click [VBA] - [Macro] - [Macros...] to display the [EZ-C1 Project] dialog box.
2. Select < All Standard Projects > in the [Macros in:] combo box to show all procedures.
3. Select "IdsTiffConvert" from the list.
4. Click the [Run] button.

4.5.2.2 IdsTiff Convert dialog box

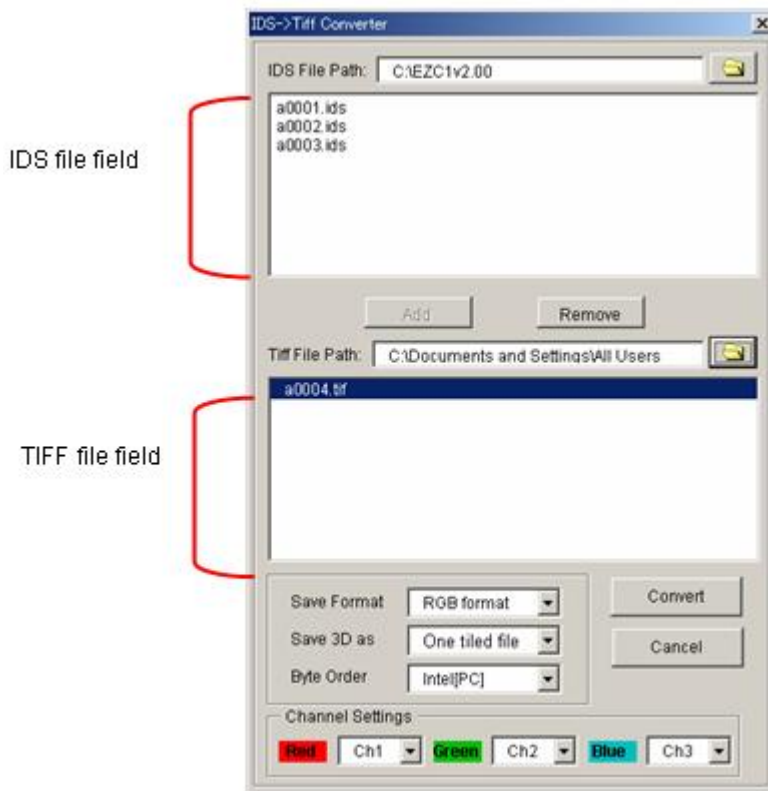

Figure 4.5-1 IdsTiff Convert dialog box

Executing “IdsTiffConvert” displays the IdsTiff Convert dialog box (Figure 4.5-1). Use this dialog box to select an IDS file from a desired folder, to convert it to a TIFF file, and to save it. Individual control functions are described below.

Name	Function Overview
IDS File Path	Sets the path to a folder containing an ids file. By clicking the Browse button at the right, a path can be set using the folder selection screen.
IDS file field	Displays the list of ids files in a specified folder.
TIFF File Path	Sets the path to a folder in which to save a TIFF file. By clicking the Browse button at the right, a path can be set using the folder selection screen.
TIFF file field	Displays the list of candidate files for conversion to the TIFF.
[Add]	Clicking this button after selecting a file in the IDS file field adds the selected file to the TIFF file field.
[Remove]	Clicking this button after selecting a file in the TIFF file field deletes the selected file from the candidates of files for TIFF conversion.
Save Format The image can be stored as:	

Raw format	The Raw format stores all data without color information or conversion. Use this format to export the image data for analysis purposes. However, there are not many programs that are able to read the raw data format.
RGB format	The RGB format stores up to 3 channels (red, green, blue). The image data is converted to 8-bits by matching the brightness to the 8-bits range. In this format, you may allocate color of channels. See the following Channels item. Re-opening this format image, channels are assigned in order of RGB. Most applications support 24-bits RGB images. Use this format to export data to applications that do not support the Raw format.
Bitmap format	The image data is saved as a 24-bit RGB tiff image that appears to the eye just like the image displayed in the window. Select this format when you wish to save figures and text along with an image using the annotation function. Use this format for presentation purposes.
Save 3D as When 3D files are saved, the image slices can be saved in one file or in separate files.	
one tiled file	Check this option to store all slices in one file.
series of files	Check this option to save each slice in a separate file with an incremented index (**_001.tiff, **_002.tiff, ...). In addition to the slice files, a text file is written with the extension .tsr (tiff series) that contains the names of the slice files. When this file is opened with the "Open" command on the "File" menu, all slice files are read and the 3D image is reconstructed. When copying or moving series of files, be sure to keep the slice files and the .tsr file together.
Byte Order The following byte orders are supported.	
Intel (PC)	Use this byte order when writing images using Intel-based computers.
Motorola (Mac)	Use this byte order when writing images using Motorola-based computers (Macintosh).
Channels	The selection which image channel is saved on each color. This item is only shown in RGB format.
[Convert]	Conversion is executed and all files in the TIFF file field are converted into tiff files.
[Cancel]	Close the dialog box without executing conversion.

4.5.3 Switch Scanning Area procedure

The default EZ-C1 project contains a Switch Scanning Area procedure. Switch Scanning Area performs global scanning setting. Two types of settings are available.

Note

- This default project cannot be used by Viewer.

4.5.3.1 Starting Switch Scanning Area

Switch Scanning Area procedure is located in the default project (Default.ezm). Selecting the Switch in the VBA menu activates Switch Scanning Area procedure.

4.5.3.2 Switch Scanning Area dialog box

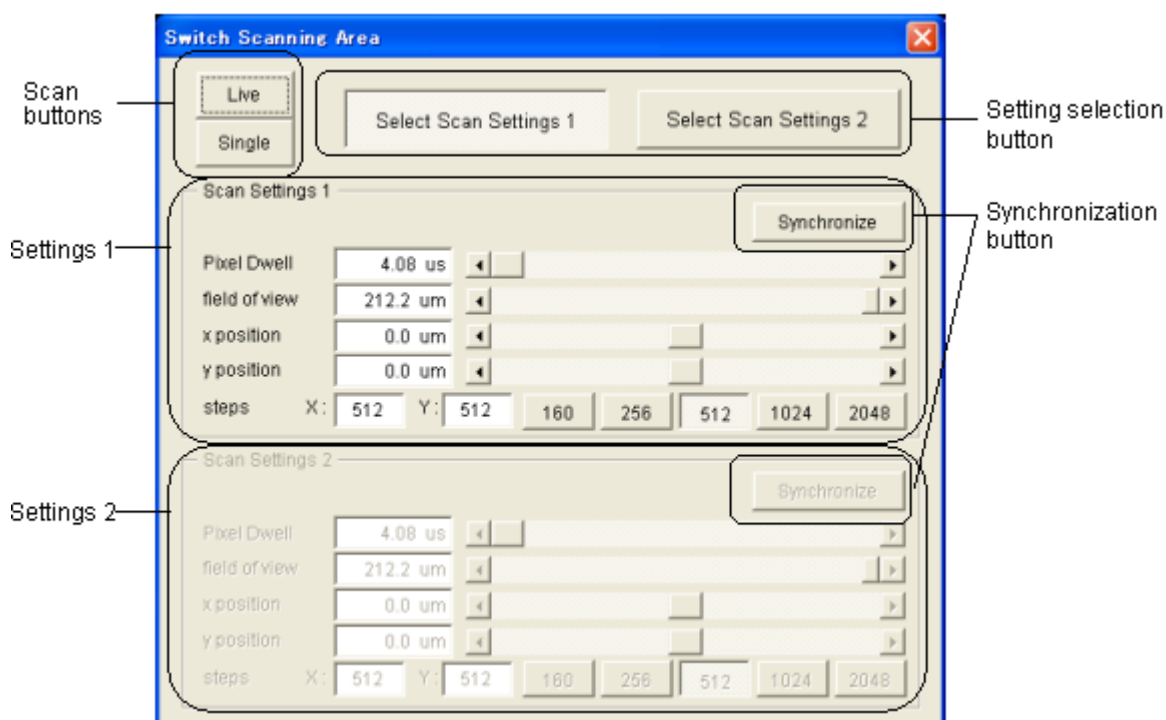

Figure 4.5-2 Switch Scanning Area dialog box

Executing "mdlSwitchSA.Switch" displays the above Switch Scanning Area dialog box (Figure 4.5-2).

The values in effect at the end of the previous session are recovered.

Switch Scanning Area can store two sets of scan area settings. The **[Select Scan Settings]** button lets the user select the desired scan settings.

Click the **[Synchronize]** button to synchronize operations with EZ-C1.

To exit Switch Scanning Area, click the **X** button in the upper right corner of the window. This saves the current settings and closes Switch Scanning Area.

Individual control functions are described below.

Name	Function Overview
Scan button	Starts a scan. Select [Live] or [Single], depending on the application. When not in synchronization mode, EZ-C1 will reflect the current settings before a scan starts.
Select Settings button	Used to select the settings to be activated. Inactive settings are grayed-out, indicating that they cannot be modified. When not in synchronization mode, EZ-C1 will reflect the active settings.
Settings 1, Settings 2	Used to enter settings to be reflected in EZ-C1. Specifications such as the range of input values and the unit of input are the same as those for EZ-C1. If the Switch Scanning Area setting values cannot be reflected in EZ-C1 for some reason (e.g., when setting values exceed EZ-C1 upper/lower limit values), the settings are invalid. The setting values are automatically saved when Switch Scanning Area closes, then automatically loaded on subsequent startup.
Synchronize button	<p>This button has two functions:</p> <p>Clicking the button reflects the current EZ-C1 settings in Switch Scanning Area. These settings include the numerical input range and the unit of input. Click the button before entering new settings.</p> <p>Pressing and holding down this button invokes synchronization mode. In synchronization mode, monitoring occurs in real-time to ensure the consistency of Switch Scanning Area and EZ-C1 settings. (There may be a slight lag in synchronization of settings during a Live scan.) This function is used to adjust settings while checking scan results. To exit synchronization mode, click the [Synchronize] button once again.</p> <p>Switch Scanning Area settings cannot be made independently in synchronization mode. Before saving, click the [Synchronize] button once again to cancel synchronization mode. Saving settings while synchronization mode is active automatically activates synchronization with EZ-C1 on subsequent startup.</p>

CAUTION

- Switch Scanning Area settings do not contain objectives. The Switch Scanning Area setting may not be properly reflected when [field of view] and other upper and lower limit values are changed due to an objective change. To switch settings, adjust EZ-C1 objectives, or click the [Synchronize] button to reflect the upper and lower values.

4.6 Spectral

4.6.1 Unmixing

The spectral data of each reagent in the spectral data of a multistained specimen is used in the unmixing calculation to show the spatial distribution of each reagent data.

Unmixing: This process calculates one multispectral data item containing multiple spectra to separate it into individual data. This makes it possible to produce separate images for each multispectral image data element.

This calculation can also be used for Time Series data and Z stack data.

The spectral data for each reagent used in the Unmix calculation can be selected from “saved spectral data” and “spot data for the target image.”

The separated data is handled as 1-channel data. The data remaining after the calculation result is shown as a remainder image.

(See Note for details.)

Important

- **Spectral data for a reagent used in an unmixing process should as far as possible be acquired at the same wavelength range and resolution as the target image data.**
- **Even if the same stain reagent is used, acquire new stain data for the specific cell when an experiment is performed on a different cell. The spectral data may vary slightly between different tissue and cell types.**
- The data may not be processed correctly unless a suitable transmission setting is made in the Configure | Confocal C1 | Spectral Detector tab.

4.6.1.1 Simple Unmix

In this process, a single click makes it possible to perform the unmixing process using the spectral data for all selected spots in the target image.

This unmix process performs the same operation as pressing the [All Spot] button as described in “(1)Spot Data Selection for the Target Image” in Section 4.6.1.2, “Unmix.”

CAUTION

- The color setting for the image in the calculation result corresponds to the spot color.
- The calculation result includes the remainder image.

4.6.1.2 Unmix

Make the settings to prepare for the unmix process before performing the unmix process. The spectral data for each reagent used in the unmix process can be selected from “saved spectral data” or “spot data for the target image.”

The remainder data can be displayed after unmixing.

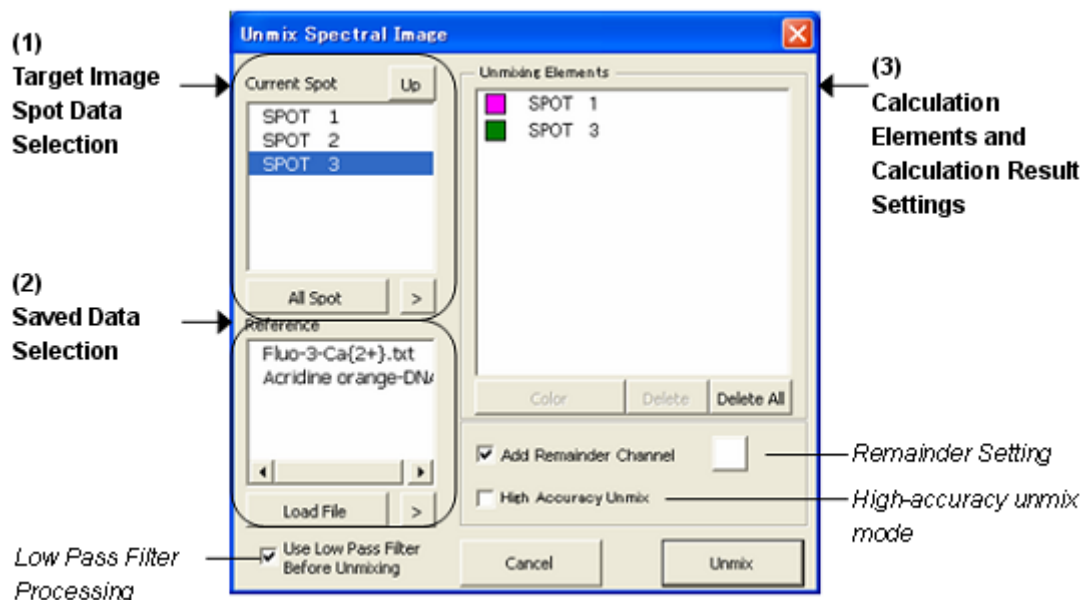
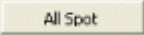



Figure 4.6-1 Unmix Spectral Image dialog box



(1) Target Image Spot Data Selection

Select spectral data for the reagent to be used in the unmix calculation from “Target Spot Data.”

Name	Function Overview
Current Spot List	Show a list of spots drawn on the target image. [UP] : Press this button to update the Current Spot list when a new spot has been added to an image.
 [All Spot]	Press to include “All spot data” in the Current Spot list in the calculation. The names of all spots appear in the Unmixing Elements list.
 [>]	Press to select spot data from the Current Spot list to be included in the calculation elements. The selected spot name appears in the Unmixing Elements list.



(2) Saved Data Selection

Select spectral data for the reagent to be used in the unmix process from “Target image spot data.”

Name	Function Overview
Reference List	Displays saved spectral data in most recently used order.
 [Load File]	Load saved spectral data as calculation elements. Select saved spectral data (.txt file data) from the “File Open” dialog box. The selected spectral data name appears in the Unmixing Elements list.
 [>]	Press to include saved spectral data selected in the Reference list in the calculation elements. The selected spectral data name appears in the Unmixing Elements list.

(3) Calculation Elements and Calculation Result Settings

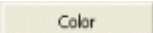
Use these settings to open the list of spectral data for each reagent to be used as calculation elements in the unmix process. Color settings for data separated in the calculation result can also be set here.

Name	Function Overview
Unmixing Elements	Shows a list of reagent spectral data used as calculation elements in the unmixing process. Set as described in (1) and (2) above.
 [Color]	Set the display color of the result image that appears after the unmix calculation. Set a display color in the reagent data. Spatial distribution of separated data is displayed using the selected colors. ! To change colors after the unmixing calculation, change the color settings in the Multi Channel Pseudo Color mode in the View Settings Color tab.
 [Delete]	Delete currently selected reagent data in the Unmixing Elements list.
 [Delete All]	Delete all reagent data in the Unmixing Elements list.
Reminder Add the remainder data to the unmixing calculation and select a color for the remainder data.	
<input checked="" type="checkbox"/> Add Remainder Channel Checkbox	This function enables calculation of remainder data in the unmixing calculation. When selected, the remainder data is shown as an image in the unmixing calculation result. When deselected, the remainder data is not shown.
Color button	Select a color to display the remainder data after the unmixing calculation result. - See the Note below for more information on remainder data.

<p>High Accuracy Unmix</p> <p>Press to perform the calculation in high-accuracy unmix mode. Here, when the unmix calculations are performed, if separate reagent data has low validity, the parameters are adjusted (deleting undesirable calculation elements) and unmix is recalculated. This Calculation therefore takes longer. This is effective if there are three or more unmix calculation elements. It is not very effective if the number of calculation elements numbers one or two.</p>	
<p><input type="checkbox"/> High Accuracy Unmix</p> <p>Checkbox</p>	<p>Select to perform the calculation in high-accuracy unmix mode. Clear to perform regular unmix calculation.</p>
<p>Low Pass Filter</p> <p>Select Low Pass Filter processing of the target image before the unmixing calculation.</p>	
<p><input checked="" type="checkbox"/> Use Low Pass Filter Before Unmixing</p> <p>Checkbox</p>	<p>Select this function to process the target image using a Low Pass Filter before unmixing. This process reduces noise present in the image before making the Unmixing calculation.</p> <p>When selected, the unmixing process is performed after low pass filter processing.</p> <p>When deselected, the unmixing process is performed without the low pass filter process.</p>
<p>Cancel</p> <p>[Cancel]</p>	<p>Press to close the dialog box without performing the unmixing calculation.</p>
<p>Unmix</p> <p>[Unmix]</p>	<p>Press to perform the unmixing calculation for the target image using the selected reagent data.</p> <p>! Separated reagent data is displayed as one channel data in the calculation result. The remainder data is also displayed as one channel data.</p>

Examples:

Multistained specimen data (GFP, YFP, RFP)

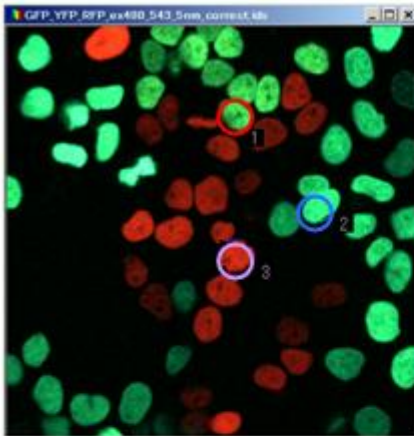

Unmixing calculated using target image spot data

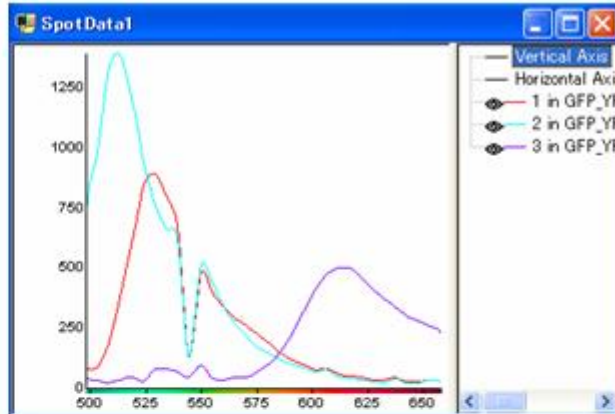

Data separated from GFP, YFP, RFG and Remainder data

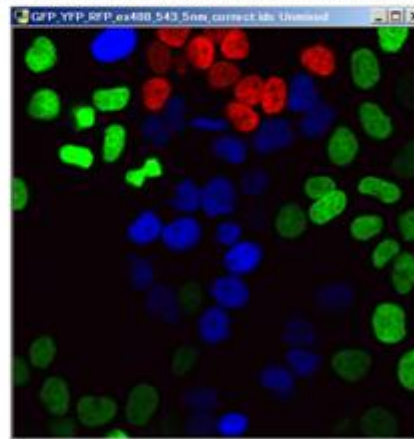

Note

<Remainder data>

- The remainder data is used as a quality standard for the data produced by the unmix calculation. The remainder data is represented as an absolute value for the total of differences between measurement data (b) and the total of unmixed data (a).

(a) Total of unmixed data:



$$S(\lambda) = \sum_n I_n \bullet R(\lambda)_n$$

$S(\lambda)$ = total unmixed data
 I_n = unmixed data

(b) Spectrum for measurement data: Remainder = | (b)-(a) |



$$\text{Remainder} = \sum_{\lambda} |S(\lambda) - E(\lambda)|$$

$E(\lambda)$ = measurement data
 $R(\lambda)$ = data used as calculation elements

This data is added as one channel data to unmixed data.

4.6.2 Segmentation

Specify a wavelength range in a spectrum data of a multiple-stained specimen to display a spatial distribution of data in the range. This function is available for time series data and Z-stack data of 3D or 4D.

The specified wavelength data is processed in the binning processing and becomes one channel data.

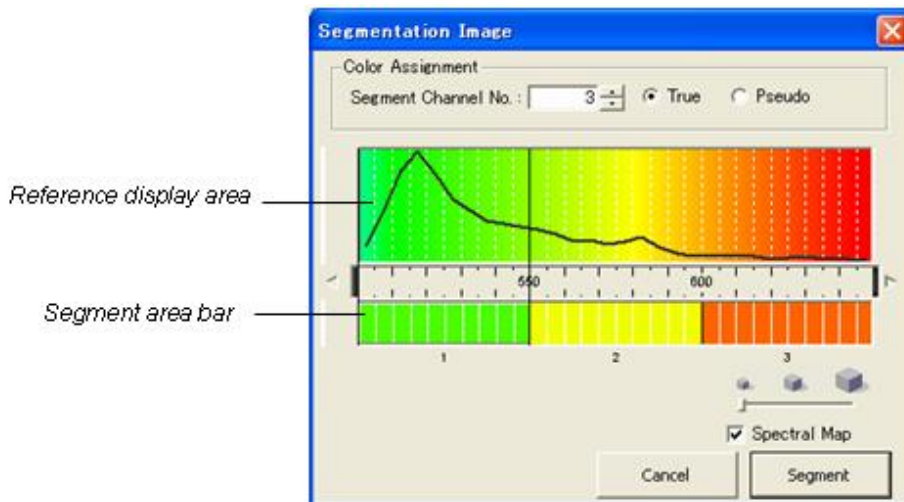
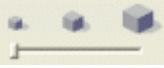

Figure 4.6-2 Segmentation Image dialog box

Name	Function Overview
Color Assignment	
Segment Channel No	Wavelength range will be divided into areas of this number. Segment area bars of this number are also displayed.
True	The spatial distribution is displayed in the color of each area. The color of the center wavelength of each area is used for it.
Pseudo	The spatial distribution is displayed in the user-defined color of each area.
Reference display area	The spectral graph of the target spot is displayed here. The vertical-axis is intensity of light and the horizontal-axis is the wavelength. When the Spectral Map checkbox is checked, the color for each wavelength will be displayed.
Wavelength scale	The wavelength range is displayed here. - When the graph is enlarged with the zoom function, triangle marks on both sides are enabled. The displayed area can be moved horizontally by dragging the scale area.
Segment area bar	The divided wavelength areas are displayed here. They are used to show the spatial distribution. To change the wavelength range, expand, compress, or slide these bars.
 Zoom	The wavelength display can be zoomed in three steps.

<input checked="" type="checkbox"/> Spectral Map Spectral Map checkbox	Check this checkbox to show the colors of wavelengths in the reference display area.
[Cancel]	Press this button to cancel the Segmentation function and close the Segmentation dialog box.
[Segment]	Apply the Segmentation function to all areas. A Segmented window appears. Binning processing (averaging) is applied for each divided areas to show images. ! - The images in the Segmented window are treated as data of channels specified in the Segment Channel No field. (It is the same number as the Segment area bars.) - Colors used for images in the Segment window can be changed on the Color tab of the View Settings window.

Example:

Multiple-stained specimen (GFP, YFP, or RFP)

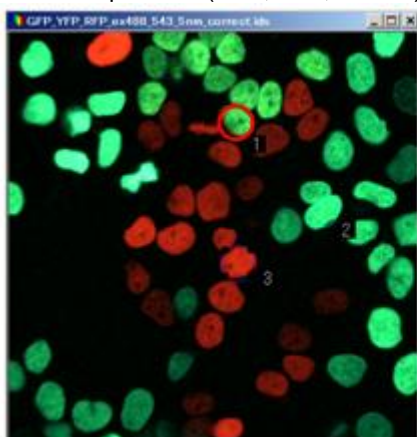

Refer to the spectral graph of the Spot and divide the area.

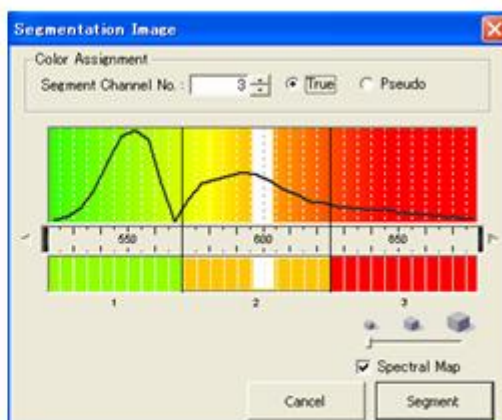

Spacial distribution is displayed for each divided area.

Segmentation

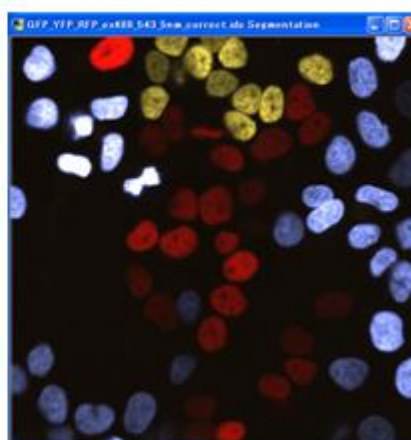

4.7 Data Series

Use the commands in the Data Series menu and the buttons on the Data Series Bar to perform view or save operations in the Data Series graph window.

CAUTION

<Calibration>

The graphs displayed here have been calibrated along the wavelength axis and brightness axis at the factory before shipment. Thus the spectral data shown here is the fluorescent spectral curve actually generated by the specimen.

- Brightness calibration of the brightness axis must be set. Check the Configure | Confocal C1 | Spectral Detector tab. (See Section 5.2.9, "Spectral Detector Tab".)

Note

- The "Data Series" appears only when the Data Series graph window is active.

4.7.1 Data Series graph

Use this graph to display, compare, verify and analyze multiple spectral data.

The following graphs can be displayed:

- Spot spectral data for target image data,
- Reference data spectral graph (data of Molecular probe and CLONTECH),
- Saved data files,
- Spot spectral graphs of open image windows other than target image.

Standardization (peak and relative value), cursor indication of graph peak values and spectral data on the Intensity axis can be saved.

Display method: Click the  on the Annotate bar or the channel checkbox on the Spot of Interest tab.

These buttons open the Data Series graph window and the Data Series menu. Data Series graph windows appear next to an active window only the first time.

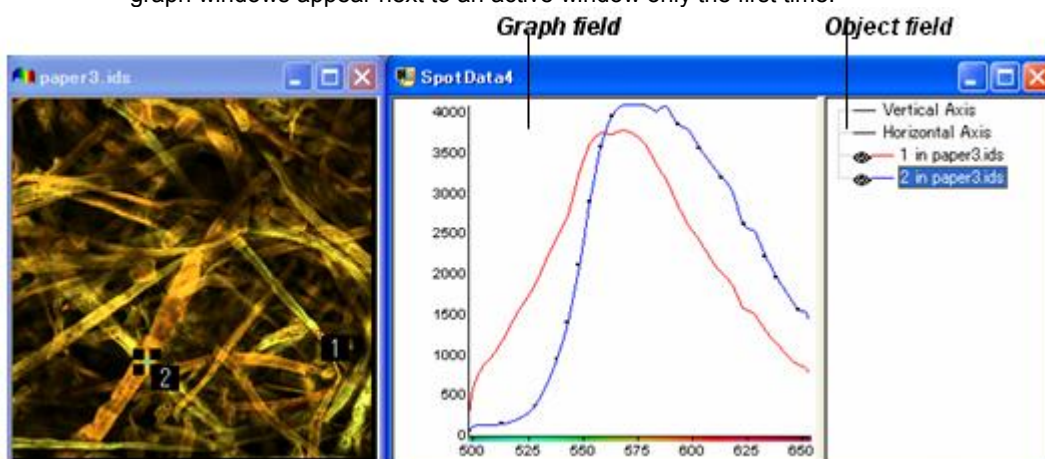

Figure 4.7-1 Spot Data dialog box

Name	Function Overview
Graph field	<p>The following graphs can be displayed.</p> <ul style="list-style-type: none"> - Spot spectral graphs of “target image data” and “open image windows other than target image.” - Spectral graph of reference data - Spectral graph of saved data
Object field	<p>Indicates object names. Right-click to make settings. (See 4.7.2.)</p>

Note

- Graph names in the object field appear as shown below. Right click to make changes in the Property dialog box that appears.
 - Spot data graph: spot name + in + image name
 - File data graph: file name
 - Reference data graph: (ex)/(em) + data name
- The horizontal axis of a graph for data acquired by the spectral detector indicates wavelength range.
- The horizontal axis of a graph for data acquired by the standard detector indicates the channel.

4.7.2 Various Settings

Use the Property dialog box for each object in the object field in the Data Series graph window to make settings.

4.7.2.1 Graph Properties

Adjust graph display settings as desired. Right-click a graph or graph object name to display three menus: "Properties," "Delete," and "Export to File."

Properties: Use to set graph data display color, smoothing, dot display for measurement points and other settings in the Property Dialog box. (See Figure 4.7-2.)

Delete: Delete graphs and spots.

Export to File: Saves graph data to a text file.

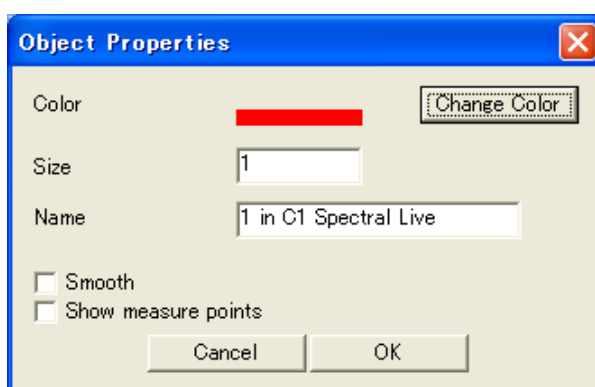

Figure 4.7-2 Property dialog box of a graph

Name	Function Overview
Color	Set the display color of the graph. Related spots become the same color. [Change Color]: shows the color palette.
Size	Set the width of the graph.
Name	Enter the name of the graph.
Smooth	Set graph smoothing.
Show measure points	Set the dot display of measure points.
[Cancel]	The settings are not incorporated in the graph and the dialog box is closed.
[OK]	The settings are incorporated in the graph and the dialog box is closed.

4.7.2.2 Vertical axis display settings

Adjust the display settings of the vertical axis (Intensity axis) as desired. Right-click the vertical axis or a vertical axis object name to display the Properties menu.

Properties: Use to set the vertical scale and make other settings in the Property dialog box.

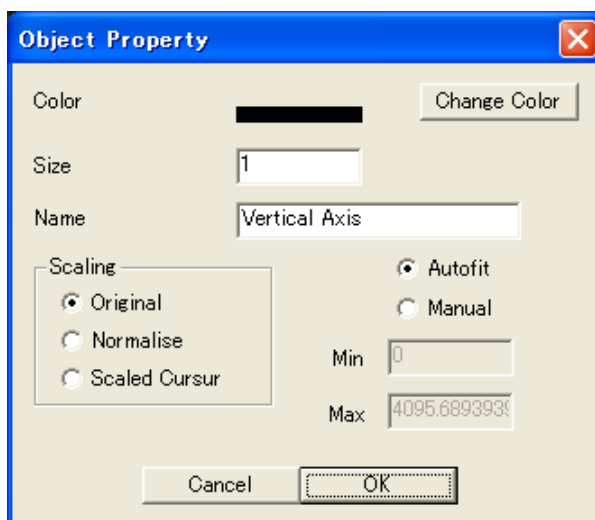

Figure 4.7-3 Property dialog box for Vertical Axis

Name	Function Overview
Color	Set the color for displaying the vertical axis. [Change Color]: Open the color palette.
Size	Set the size for displaying the vertical axis.
Name	Set the name of the vertical axis.
Scaling	Set the scale of the vertical axis. Original: Peak data becomes the highest value on the scale. Normalize: Peak data is indicated as "1" on the scale. Scaled Cursor: The scaling cursor appears and the intersection of the scaling cursor and a graph is indicated as "1."
Autofit	Set the vertical axis automatically. Automatically adjusts the axis according to the maximum scale value.
Manual	Set the vertical axis manually. Min: Enter the minimum value. Max: Enter the maximum value.
[Cancel]	Close the dialog box without applying the settings to the vertical axis.
[OK]	Apply the settings to the vertical axis and close the dialog box.

4.7.2.3 Horizontal axis display settings

Adjust the display settings of the horizontal axis (wavelength axis) as desired. Right-click the horizontal axis or a horizontal axis object name to display the Properties menu.

Properties: Use to set horizontal scale and make other settings in the Property dialog box.

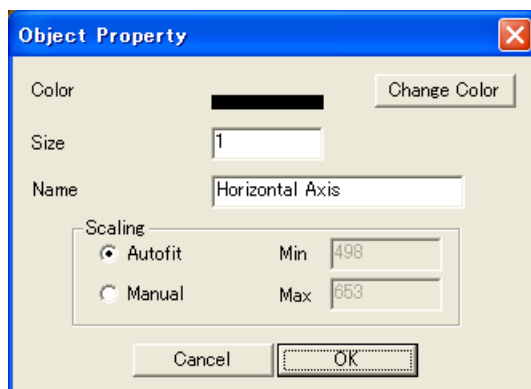

Figure 4.7-4 Property dialog box for Horizontal Axis

Name	Function Overview
Color	Set the color for displaying the horizontal axis. [Change Color]: Open the color palette.
Size	Set the width for displaying the horizontal axis.
Name	Set the name of the horizontal axis.
Scaling	Set the scale of the horizontal axis. Autofit: Scales the horizontal axis automatically using the minimum wavelength as the minimum value and maximum wavelength as the maximum value in multiple graphs. Manual: Enter the minimum and maximum values.
[Cancel]	Close the dialog box without applying the settings to the horizontal axis.
[OK]	Apply the settings to the horizontal axis and close the dialog box.

4.7.2.4 Cursor Properties

Adjust the cursor display settings as desired.

Right-click the cursor or cursor object name to display two menus: "Properties" and "Delete."

- Properties:** Use to set the display color, width and other settings in the Object Property dialog box. (See the dialog box below.)
- Delete:** Delete the cursor.

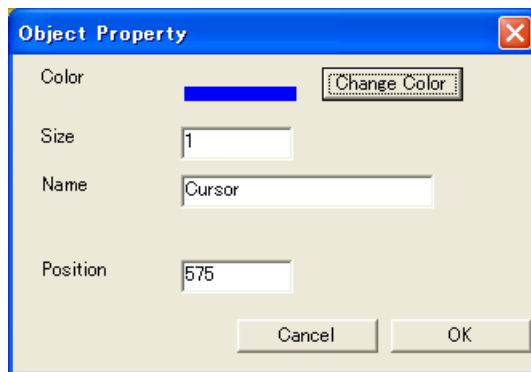



Figure 4.7-5 Cursor Property dialog box

Name	Function Overview
Color	Set the display color of the cursor. [Change Color]: Open the color palette.
Size	Set the width of the cursor.
Name	Set the name of the cursor.
Position	Indicate and change the current wavelength position of the cursor.
[Cancel]	Close the dialog box without applying the settings to the cursor.
[OK]	Apply the settings to the cursor and close the dialog box.

4.7.3 Cursor

Use the “Cursor” command in the “Data Series” menu or the  button on the Data Series bar to display a cursor in a Data Series graph.

The following cursors can be displayed.

- Normal cursor
- Top cursor
- Scaling cursor

4.7.3.1 Normal Cursor

This is the normal cursor that can be freely moved around with the mouse.

Display method: Select the “Insert Normal Cursor” command from the “Data Series” menu or click the  button on the Data Series bar.

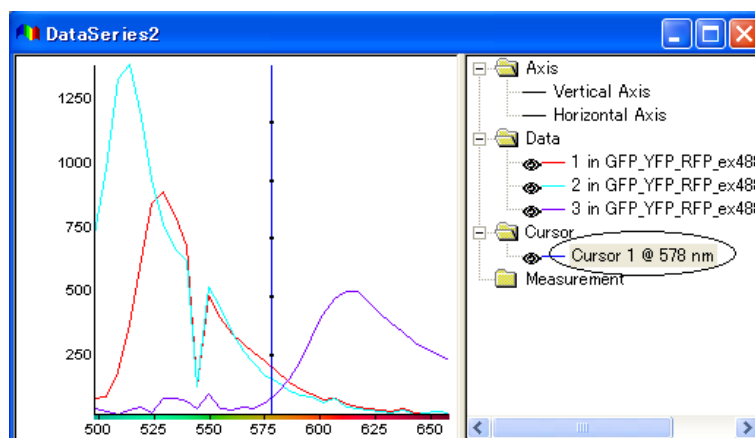

4.7.3.2 Top Cursor

The Top cursor appears at the peak position of an active graph. In the objective field, the top cursor indicates wavelength position.

Display method: Use the “Insert Top Cursor” command in the “Data Series” menu or click the  button on the Data Series bar.

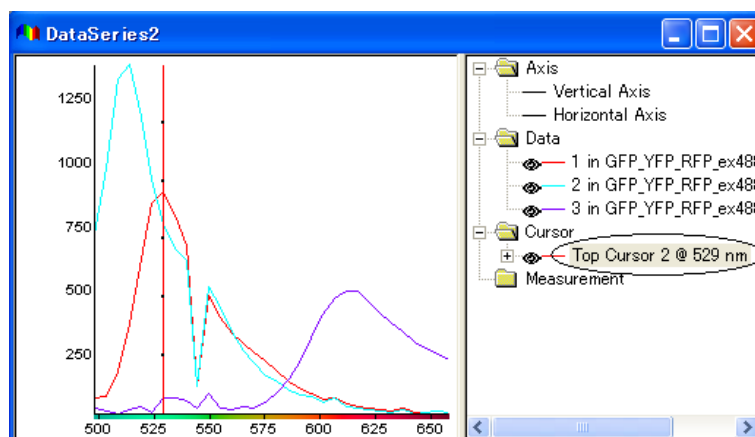

4.7.3.3 Scaling Cursor

Use this function to display the scaling cursor in an active graph. The intersection between the graph and cursor is always "1." The wavelength location of the scaling cursor is shown in the object field.

Display method: Use the Insert Scaling Cursor command in the Data Series menu or click the  button on the Data Series bar.

→ The Scaling cursor is displayed and the Vertical Axis scale settings are automatically updated with the Scaling Cursor.

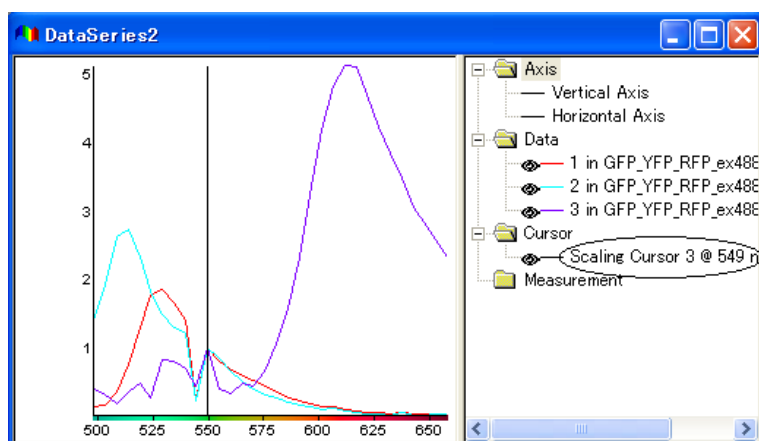

4.7.4 Basic arithmetic operations on graph items

You can perform basic arithmetic operations on two graph items using the Calculate command in the Data Series menu.

In the Calculate tab, you can choose the target graph and calculation method. You can also apply a coefficient to each graph item.

The calculation methods are as follows.

- $(a * A) + (b * B)$: Addition
- $(a * A) - (b * B)$: Subtraction
- $(a * A) \times (b * B)$: Multiplication
- $(a * A) / (b * B)$: Division

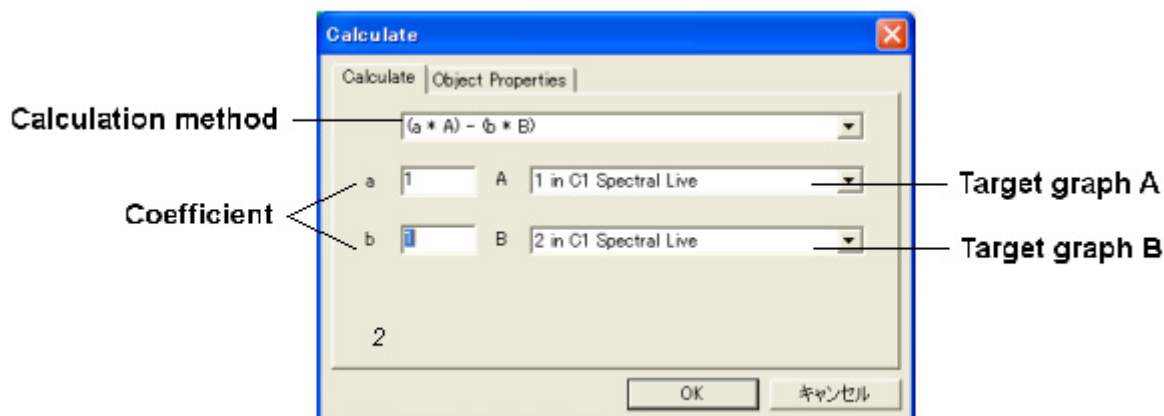

Adjust the display settings as desired in the Object Properties tab. These settings are the same as the graph display settings. (See 4.7.2.1.)

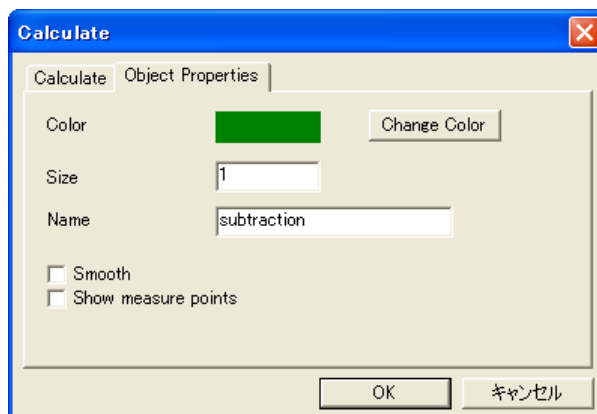

Calculation results are displayed as data in the graph field and object field.

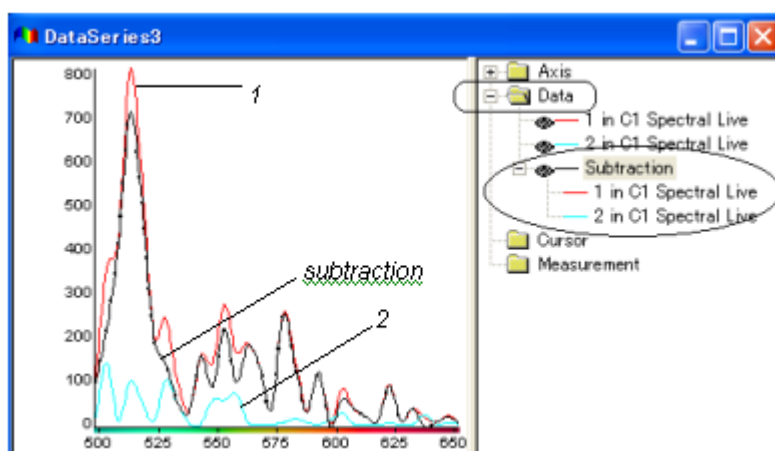

4.7.5 Measurement functions

The following measurement functions are available from the Measure command of the Data Series menu.

- Cursor Distance function: Measures the distance of the wavelength between two cursors.
- Height function: Measures the intensity of graph items at the cursor position.
- Integrated Intensity function: Calculates the integrated value of the intensities of two cursors on a graph.
- Peak Width function: Measures the distance of the wavelength for the half-height (intensity) of the peak position in the graph.
- Ratio function: Calculates the ratio of two cursors (P1/P2).

4.7.5.1 Cursor Distance function

Measures the distance of the wavelength between two cursors. Cursors can be freely repositioned in the graph field for measurement.

In the Cursor Distance Measurement tab, specify both cursors.

- Cursor 1 and 2: Select the two cursors from cursors that are already displayed.
To display a new cursor, select New.

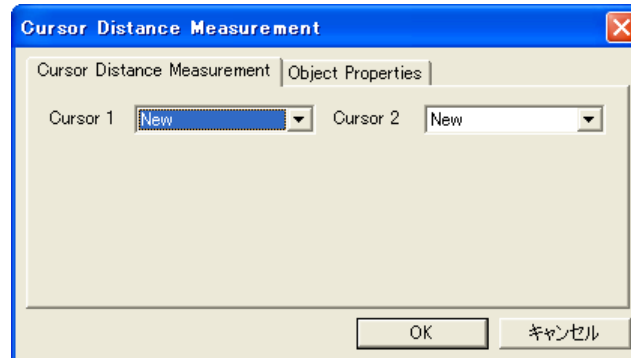

Adjust the display settings as desired in the Object Properties tab. These settings are the same as the cursor display settings. (See 4.7.2.4.)

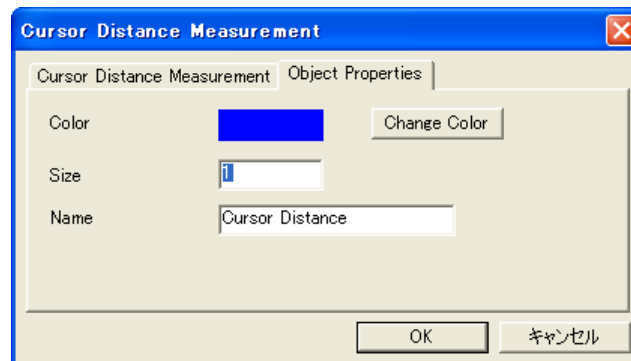

The graph field indicates the settings status, and the object field indicates measurement results.

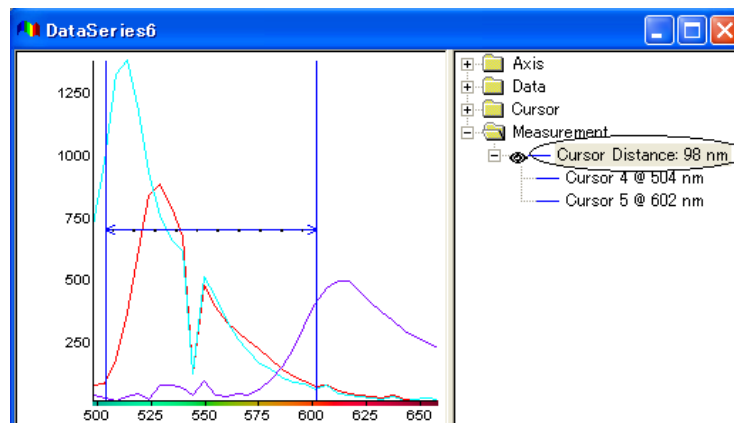

4.7.5.2 Height function

Measures the intensity of graph items at the cursor position. The cursor can be freely repositioned in the graph field for measurement.

In the Height Measurement tab, specify the cursor.

- Cursor: Select the cursor from cursors that are already displayed.
To display a new cursor, select New.

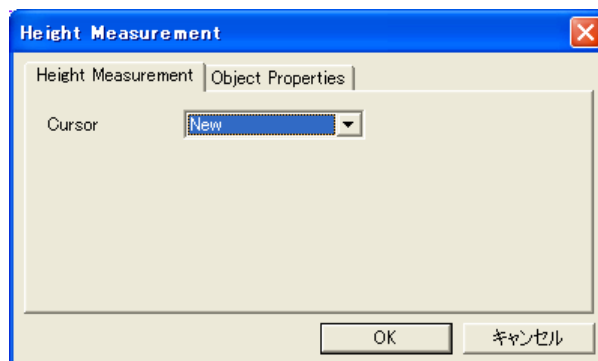

Adjust the display settings as desired in the Object Properties tab. These settings are the same as the cursor display settings. (See 4.7.2.4.)

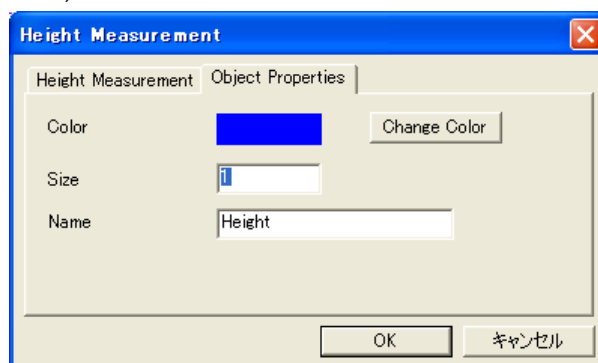

The graph field indicates the settings status, and the object field indicates measurement results.

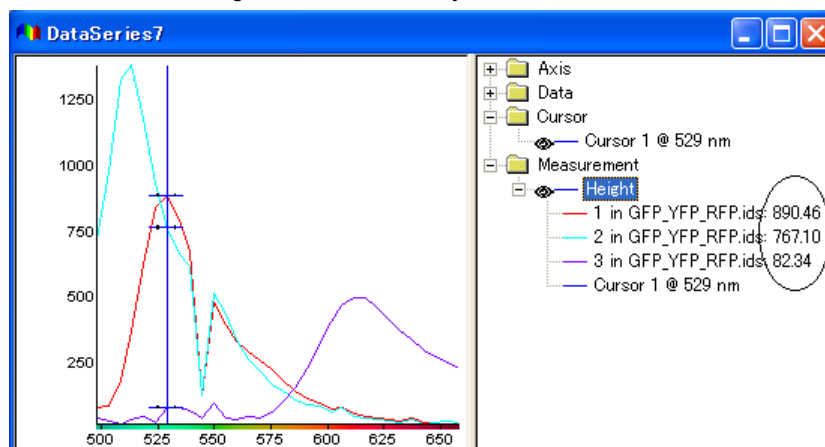

4.7.5.3 Integrated Intensity function

Calculates the integrated value of the intensities of two cursors on a graph. The cursors can be freely repositioned in the graph field for measurement.

In the Integrated Intensity Measurement tab, specify the target graph and both cursors.

- DataSeries: Select the target graph from graphs that are already displayed.
- Cursor 1 and 2: Select the two cursors from cursors that are already displayed.

To display a new cursor, select New.

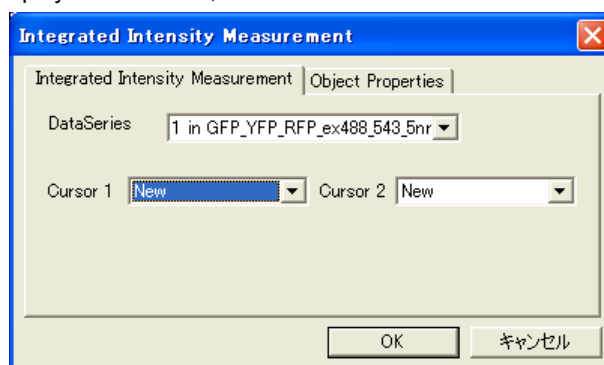

Adjust the display settings as desired in the Object Properties tab. These settings are the same as the cursor display settings. (See 4.7.2.4.)

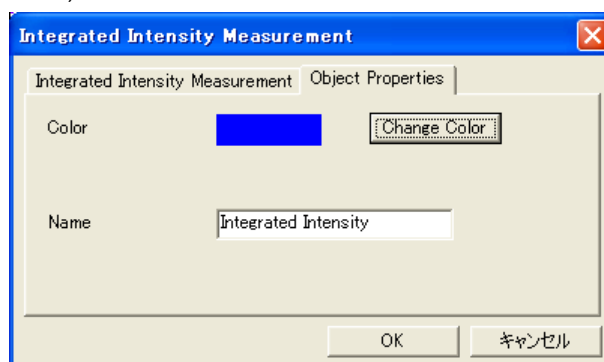

The graph field indicates the settings status, and the object field indicates calculation results.

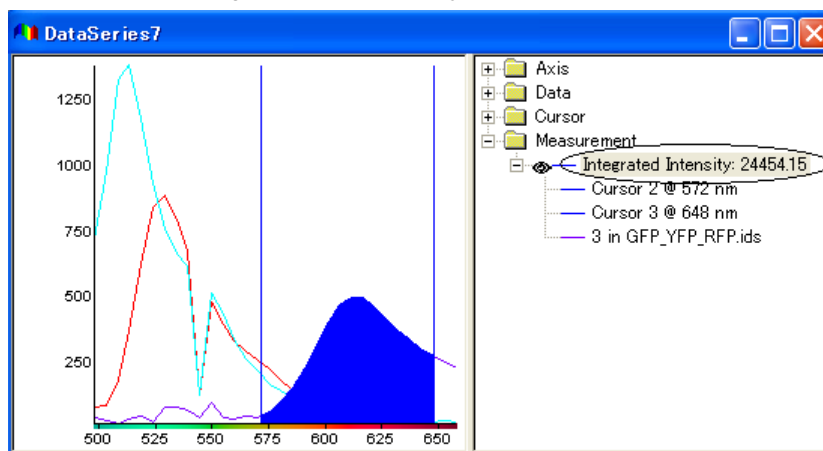

4.7.5.4 Peak Width function

Measures the distance of the wavelength for the half-height (intensity) of the peak position in the graph. The cursor can be freely repositioned in the graph field for measurement. Move the top cursor until it is fixed at the peak position.

In the Peak Width tab, specify the target graph and the cursor.

- DataSeries: Select the target graph from graphs that are already displayed.
- Cursor: Select the cursor from cursors that are already displayed.
To display a new cursor, select New.

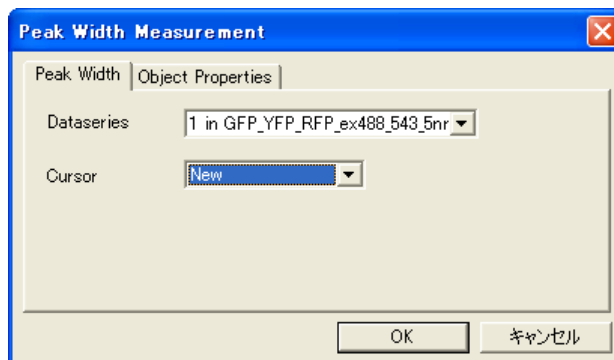

Adjust the display settings as desired in the Object Properties tab. These settings are the same as the cursor display settings. (See 4.7.2.4.)

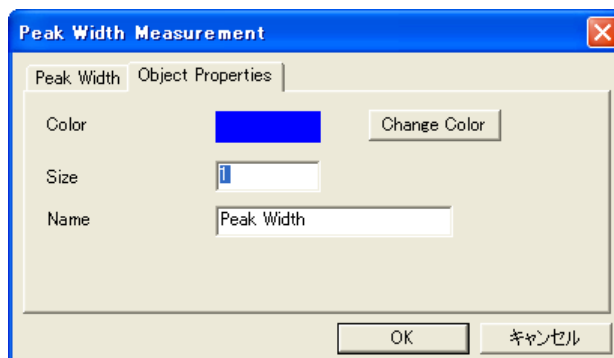

The graph field indicates the settings status, and the object field indicates measurement results.

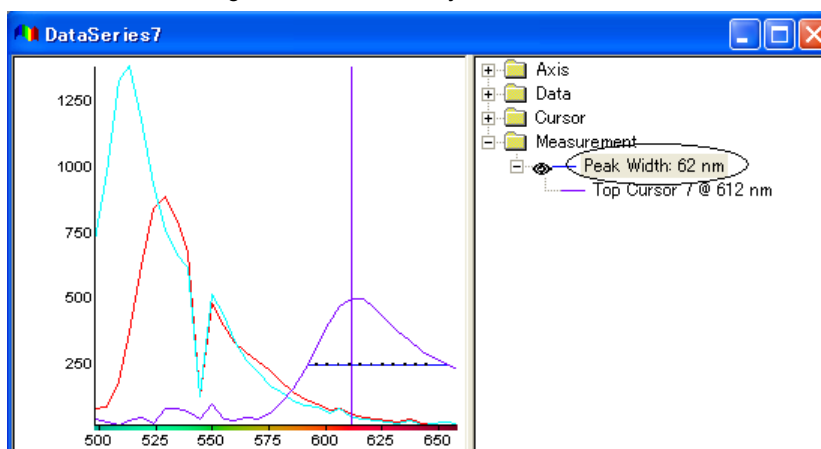

4.7.5.5 Ratio function

Calculates the ratio of two cursors (P1/P2). The cursor can be freely repositioned in the graph field for measurement.

In the Ratio Measurement tab, specify both cursors for wavelength selection.

- Cursor 1 and 2: Select the two cursors from cursors that are already displayed.
To display a new cursor, select New.



Adjust the display settings as desired in the Object Properties tab. These settings are the same as the cursor display settings. (See 4.7.2.4.)

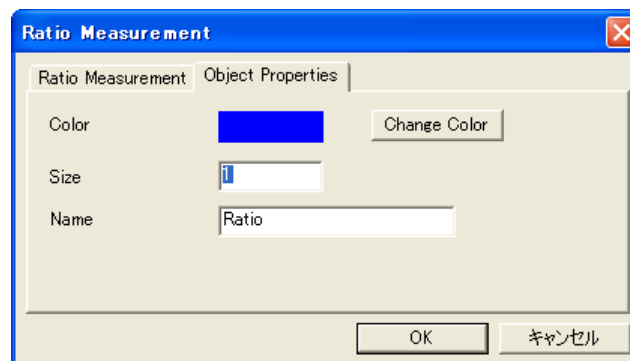

The graph field indicates the settings status, and the object field indicates calculation results.

The ratio of intensities (P1/P2) is calculated for the two cursor positions (wavelengths) in the graphs.

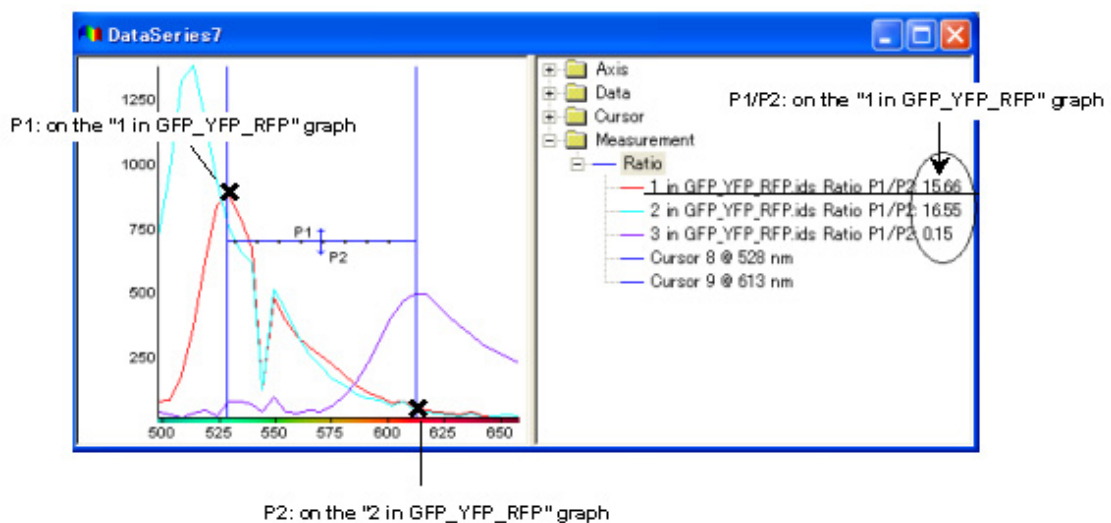

4.7.6 Inserting Graphs

Use the “Data Series Insert” command in the “Data Series” menu or click the  button on the Data Series bar to open the Insert Data Series window to insert a graph in a Data Series graph window.

The following graphs can be inserted.

- Reference spectral graph (Molecular probe and Clontech data (abstract) are provided).
- Saved data files
- Spot spectral graphs of other open image windows.

4.7.6.1 EZ-C1 Tab

Select a currently open image window in EZ-C1 from the EZ-C1 tab in the Insert Data Series dialog box to insert spot spectral data in the image window.

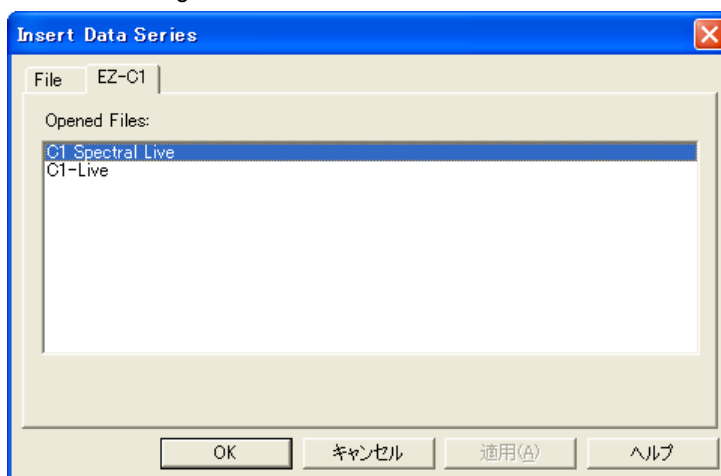

Figure 4.7-6 Insert Data Series dialog box

4.7.6.2 File Tab

Use the File tab in the Insert Data Series dialog box to insert saved spectral data (data saved by the user or reference spectral data). The Recent Files list shows recently selected spectral data listed in most recent order. Use the [Browse...] button to select other data.

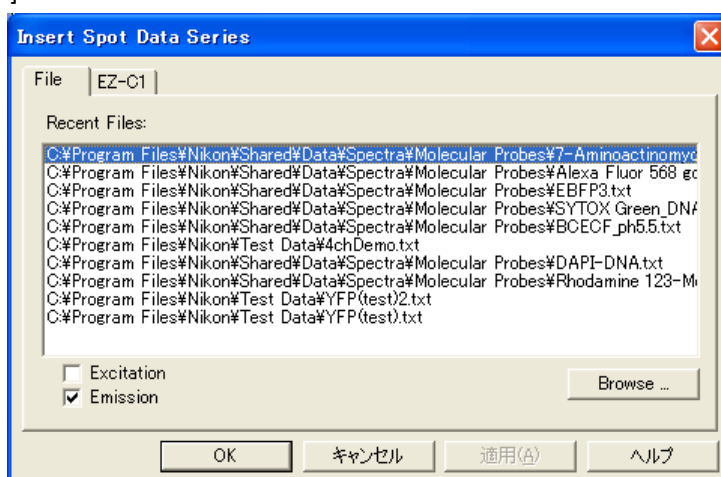
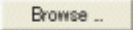

Figure 4.7-7 Insert Data Series dialog box

Name	Function Overview
Recent Files	Recently selected spectral data files listed in most recent order.
Excitation Emission	Selecting reference spectral data (data of Molecular probe manufactured by CLONTECH (abstract)) enables you to also select excitation wavelength data and emission wavelength data. Select Excitation to open excitation (absorption) wavelength data. Select Emission to open emission wavelength data. Select both to show both.
 [Browse..]	Press this button to open the File Open dialog box to select saved data. Use this function to open a file other than those listed in the Recent Files list.

Note

- **The reference spectral data** (an excerpt of Clontech molecular probe data) is stored in the following folder.

C:\Program Files\Nikon\Shared\Data\Spectra\Molecular Probes

When data is selected from this folder, the Excitation and Emission check boxes appear in the lower left corner of the dialog box. Use these checkboxes to select Excitation or Emission data.

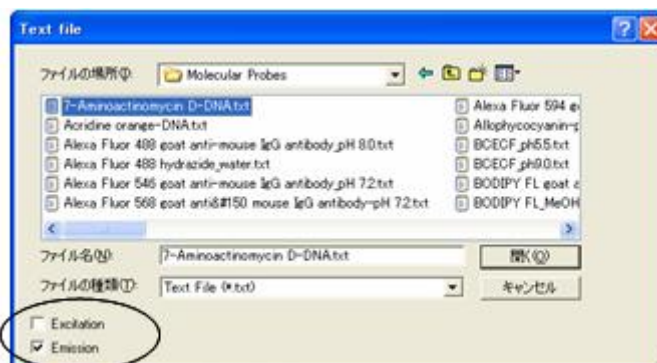

4.7.7 Saving Graphs

Use the Export to File command in Data Series of the Data Series menu, the  button in the Data Series bar or the object field in the Data Series graph window to save spectral graph data to a text file.

Save method: Select the name of spectral data to be saved in the object field of the Data Series graph window and run the Export command or press the  button. Or right-click the spectral data name and select Export to File.

→The Save File dialog box opens. Enter a name and save as a text (.txt) file.

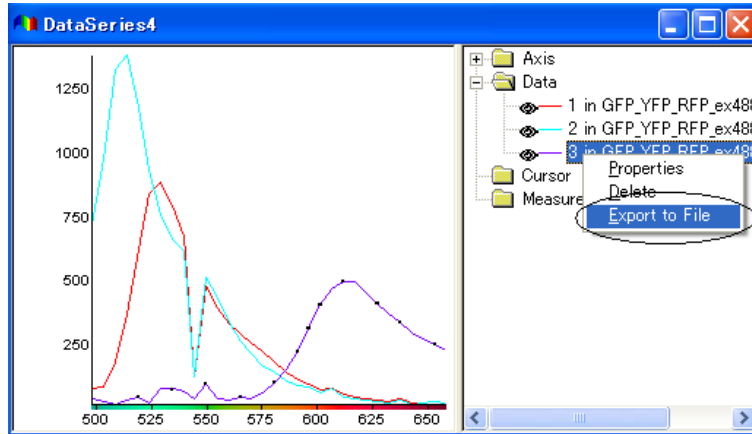





4.7.8 Data Series/ Data Series Bar



The commands in the “Data Series” menu and the buttons on the Data Series bar provide the following functions.

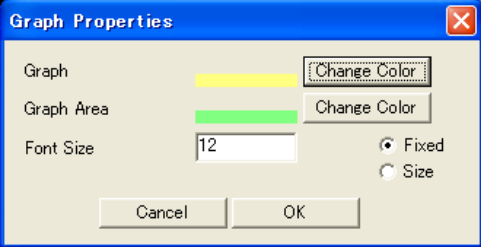

CAUTION

- The “Data Series” menu and the Data Series bar are available only when a Data Series graph window is active.

Name		Function Overview
Calculate		Basic arithmetic operations for two items of graph data. A coefficient can be applied to each graph item.
Cursor	Insert Normal Cursor 	Displays the normal cursor.
	Insert Scaling Cursor 	Displays the Scaling cursor. ! The vertical axis setting automatically becomes the Scaling Cursor setting.
	Insert Top Cursor 	The Top cursor appears at the peak position of selected wavelength.
Data Series	Export 	Save graph data in text file format.
	Insert 	Insert graph data. Inserts “spot data for other images,” “Reference data” and save data” from the Insert Data Series dialog box.
Graph	Properties	Sets the view settings for the Data Series graph window.  <p>Graph: Set the outer background color of the graph axis. Graph Area: Set the inner background color of the graph axis.</p>

Measure	Cursor Distance	Measures the distance of the wavelength between two cursors.
	Height	Measures the intensity of graph items at the cursor position.
	Integrated Intensity	Calculates the integrated value of the intensities of two cursors on a graph.
	Peak Width	Measures the distance of the wavelength for the half-height (intensity) of the peak position in the graph.
	Ratio	Calculates the ratio of two cursors (P1/P2).
Object	Delete	Delete the selected object.
	Properties	Display the properties dialog box for the selected object.
	Visible	Show or hide the selected object.
Vertical Axis	Absolute 	Place on the axis of a scale containing intensity values.
	Normalize 	Place on the axis of a normalized scale.
	Scaling Cursor 	Place on the axis of a scaled scale. (The intersection between the scaling cursor and the graph is indicated as "1".) The Scaling Cursor is also displayed.

4.8 Tools

The Tools menu lets you show or hide the tool dialog boxes and toolbars. This menu provides access to all EZ-C1 dialog boxes and toolbars.

The dialog boxes and toolbars displayed on the Tools menu are listed below.

- Acquire Bar (see 3.4.10) (*)
- Acquire Mode Bar (see 3.4.12)
- Acquire Position Bar (see 3.4.11) (*)
- Acquire Settings (see 3.4 and 3.5) (*)
- Annotate Bar (see 4.3.2)
- Bi-Directional Scan (see 3.4.9) (*)
- CLEM Bar (see 3.10) (*)
- Data Bar (see 4.3.8)
- Data Series Bar (see 4.7.8)
- File Bar (see 4.1.12)
- Function Keys (see 6.1.1.1)
- Gain Bar (see 3.3) (*)
- Laser and Detector (see 3.1) (*)
- Laser Control Bar (see 3.7) (*)
- Laser Power Monitor (see 3.8) (*)
- Objective Bar (see 3.9) (*)
- Perfect Focus System Bar (see 5.4.4) (*)
- Projects Bar (see 6.1.5)
- Stage (see 5.6.3) (*)
- Status Bar (see 4.8.2)
- Time Series Progress (see 3.5.6)
- View Bar (see 3.6.4)
- View Settings (see 3.6)

The dialog boxes and toolbars marked with (*) are used for C1 hardware operations.

4.8.1 Layout of the Tools dialog box

4.8.1.1 Showing and hiding the dialog box

Selecting an item on the Tool menu lets you choose to show or hide the corresponding Tool dialog box or Tool bar. If the check box for an item on the Tool menu is selected, the dialog box for that item is displayed. If the check box is unselected, the dialog box is not displayed. A list of Tools menu items can also be displayed by right-clicking the dialog box. (See Note.)

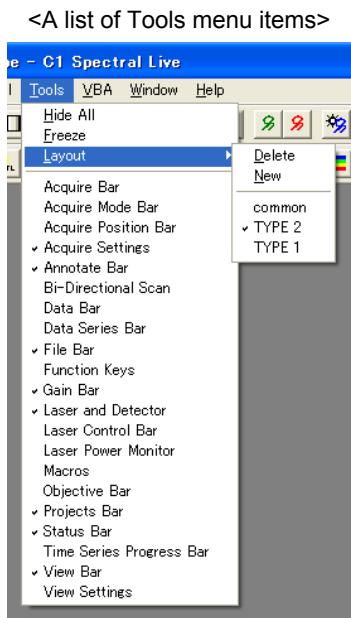

Name	Function Overview
Hide All	Hide all Tools dialog boxes and toolbars. To restore the previous display status, select this item again.
Freeze	Freezes Tools dialog boxes and toolbars in the position of the current display. To cancel this setting, select Freeze again.
Layout	<p>Configures the display of the Tools dialog boxes and toolbars as desired.</p> <p>Delete: Deletes the selected layout name.</p> <p>! The Common layout cannot be deleted.</p> <p>New: Saves the current display state of the Tools dialog box (that is, its layout settings) with a name you enter. The layout name you create will be added to the bottom of the Layout menu.</p> <div style="display: flex; justify-content: space-around; align-items: flex-start;"> <div data-bbox="571 1626 1011 1861" style="border: 1px solid black; padding: 5px;"> </div> <div data-bbox="1075 1680 1385 1861" style="border: 1px solid black; padding: 5px;"> </div> </div> <p>Layout Names (including Common): The names of layouts created by using the New command are listed here. Select a layout name to display it. (Common is a preset layout. It includes the layout elements common to various dialog boxes and toolbars.)</p>

Note

- Hide All is also available by pressing the F12 shortcut key. Pressing the F12 key switches between showing and hiding all Tools dialog boxes and toolbars.
- You can display a list of Tools menu items by right-clicking the dialog box. At this time, the additional items "Hide," "Float," and "Dock" are displayed above the list. These functions work as follows.

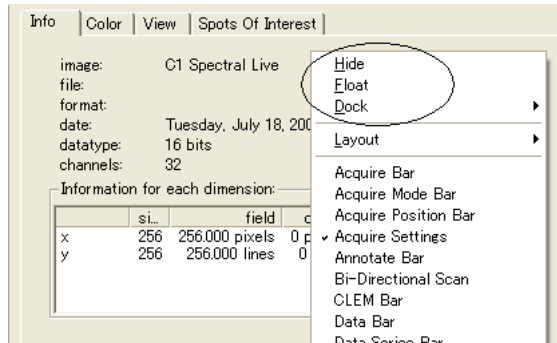

Hide: Hides a dialog box.

Float: Sets a tool bar to a floating position.

Dock: Sets a tool bar to a docking position. (Left, Right, Top, Bottom)

4.8.1.2 Floating and docking

Each toolbar can be set to a floating or docked position. Docked toolbars can also be moved.

Float: The toolbar is made an independent dialog box that is not associated with any other window.



To make a docked dialog box a floating one, double-click on the vertical gray line at the left edge of the toolbar (marked above with a circle). Or grab this part and move the toolbar from the docked position.

Right-click on the title bar to display a Tools menu list, and then select "Float."

Docking: A Tool dialog box is "docked" to (or joined together with) the EZ-C1 proper or to another Tool dialog box.



To dock a floating dialog box, double-click the vertical gray line at the left edge of the toolbar (marked above with a circle). Or grab this part and move the toolbar into a docking position.

Right-click on the title bar to display a Tools menu list, and then select "Dock."

4.8.2 Status bar

The Status bar (Figure 4.8-1) is a tool window at the bottom of the main window that displays information on the cursor position on the image. The Status bar can be displayed by checking “Status bar” on the “Tools” menu.

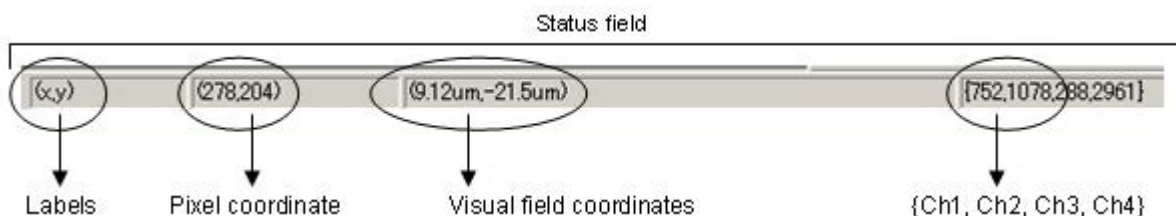

Figure 4.8-1 Status toolbar

Name	Function Overview
Status field	This field shows information on mouse position, etc. when the mouse pointer is moved over an image.
Label	Shows the coordinates for the point within the image indicated by the mouse pointer.
Pixel coordinate	Shows the coordinates of the pixel for the position indicated by the mouse pointer. For 2-dimensional images, the upper left corner coordinates are (0, 0).
Visual field coordinate	Shows the coordinates of the visual field indicated by the mouse pointer. The center coordinates are (0 μ m, 0 μ m).
{Ch1, Ch2, Ch3, Ch4}	Shows the brightness values for Ch1, Ch2, Ch3, and Ch4 of the pixel indicated by the mouse pointer. The brightness values for undisplayed channels are left blank.

4.9 VBA

See “6 Visual Basic for Applications Support Functions.”

4.10 Window

Use the Window menu to adjust the monitor brightness (for use in a dark room), as well as to reselect, copy, or merge windows.

4.10.1 Dark Room mode

When working in a dark room, you can dim the monitor while maintaining the brightness of the image window.

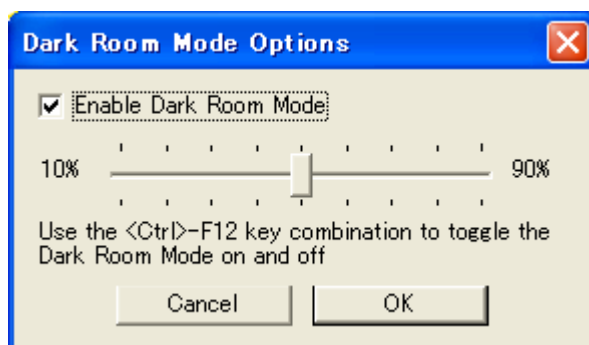

Name	Function Overview
Enable Dark Room Mode	Select this check box to apply the brightness setting. All parts of the monitor, with the exception of the image window, will be dimmed to the specified brightness.
Scroll Bar	Adjusts the brightness of the monitor. You can dim the monitor by 10 to 90%.
[Cancel]	Closes the dialog without applying the settings.
[OK]	Closes the dialog and applies the settings.

Note

- You can toggle the Dark Room Mode on and off with the key combination of <Ctrl>+F12.

4.10.2 Freeze Window Layout, Next, New, Previous, Tile, Opened Window

Name	Function Overview
Freeze Window Layout	Select this command to disable moving the image windows.
Next	Select this item to set the window created after the currently active window as the active one. If this item is selected while the most recently created window is active, then the first window created becomes active.
New	Create a new window for the currently active image. The new window will show the same image as the image that is active when the new window is created. However, all display settings can be changed individually.

Previous	Select this item to set the window created before the currently active window as the active one. If this item is selected while the first window created is active, then the most recently created window becomes active.
Tile	Arrange all windows in a tiled fashion, changing windows size to see all of them at once.
Opened Window	The windows currently being displayed are entered in a list, and a mark is applied to the active window. Also, selecting a window from this list makes it active window.

4.10.3 Merge

This function merges multiple images into one window as you display or save them. The brightness in the overlapping image areas in the merged window is obtained by adding the brightness values of the original two images. (Figure 4.9-1)

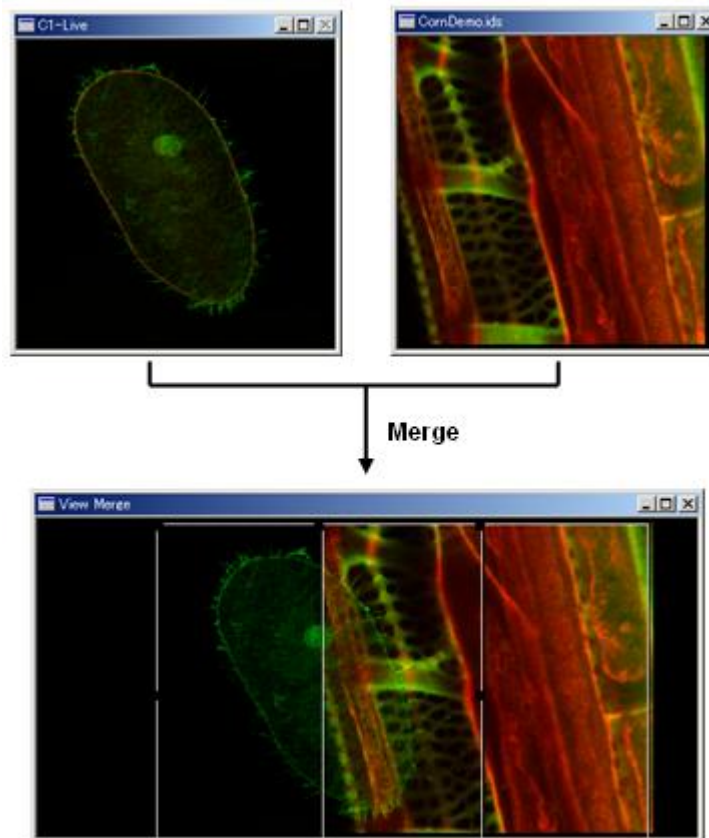

Figure 4.9-1 Merge

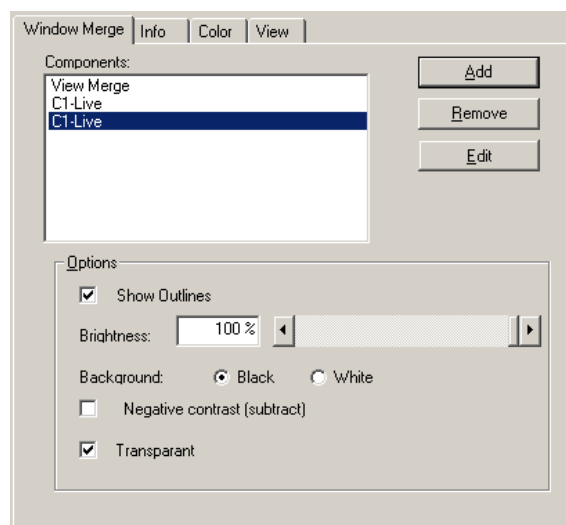



Figure 4.9-2 Window Merge tab

The following settings are available on the Window Merge tab.

Name	Function Overview
[Add]	Press this button to place a new image on top of another. The procedure for stacking images is described below.
[Remove]	Deletes the selected image in the list from those displayed in the ViewMerge window.
[Edit]	Press this button to write information to the images in the ViewMerge window during Annotate, etc. Unless this button is depressed, dragging an image only lets you move it.
Show Outlines	Hides the white border on each image in the ViewMerge window.
Brightness	Lets you change the brightness of the image selected in the ViewMerge window. The brightness can be adjusted down to 0% with respect to a brightness scale in which brightness immediately after merge is 100%. If the brightness in the overlapping image areas is saturated, use this function to adjust.
Background	Specify the background color other than the images in the ViewMerge window. Select White when a white background is required when, for example, printing images. - If the Transparent check box is selected when Background = White, the whole of the window will become white because the background color is transparent.
Negative contrast	Reverses the displayed color.
Transparent	Renders transparent the image selected in the ViewMerge window.

Note

- Follow the procedure described below to Merge.
 - (1) Display the image on which another image is to be stacked (let it be "image A") and the image to be stacked (let it be "image B").
 - (2) Select the window in which image A is displayed.
 - (3) Select Merge from the Window menu.
The View Merge window will be displayed along with image A, with the Window Merge tab (Figure 4.9-2) displayed in View Settings.
 - (4) Press the [Add] button on the Window Merge tab in View Settings.
The mouse icon will change shape to .
 - (5) Select the window in which image B is displayed.
Image B will be displayed on top of image A in the View Merge window.
 - (6) Drag the image in View Merge to alter the size or position of each image.

4.11 Help

Start up EZ-C1 Help and EZ-C1 Macro Reference. Display the application and firmware versions.



Note

- EZ-C1 Help is also available by pressing the F1 shortcut key.

5

Hardware-related Settings

5.1 Nikon RFA Z-drive

Select “Z-drive RFA” command on the “Configure” menu. The RFA Z-drive Configuration dialog box (Figure 5.1-1) is opened. This dialog box contains RFA and Scan tabs.

5.1.1 Installing the RFA Z-drive

Follow the instructions in the RFA Z-drive manual and “Hardware Manual” for installation.

5.1.2 The RFA tab

The RFA tab (Figure 5.1-1) is used to set RFA information.

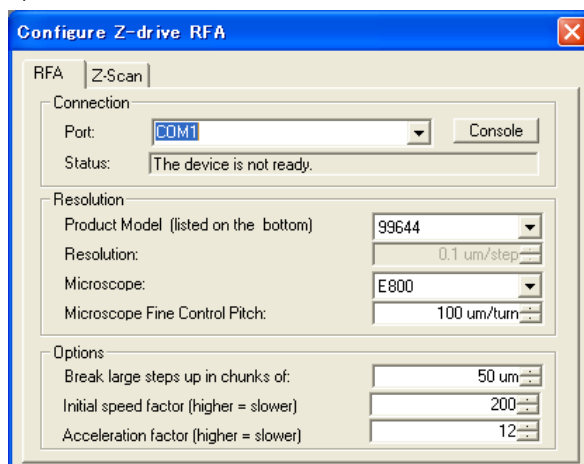

Figure 5.1-1 RFA tab

Each of the parameters has the following meaning:

Name	Function Overview
Connection	
Port	The serial port to which the RFA port is connected. COM1 or COM2 can be selected from the list.
Status	“OK” is displayed while the system is running normally.
[Console]	Pressing this button to open a console window which displays ongoing communications between the RFA unit and the computer.

Resolution	
Product Model	The RFA model number (labeled on the bottom of the device).
Resolution	The unit for reading the Z-step is automatically set according to the RFA model specified in "Product Model." Selecting "Others" in "Product Model" permits the entry of any numeric value.
Microscope	Select the microscope model to which the Z-drive is mounted. Selecting a new microscope model will automatically set the Microscope Fine Control Pitch.
Microscope Fine Control Pitch	Enter the travel of the table for one full turn of the microscope fine control pitch. When the Nikon E600FN is selected, it is set to 300 $\mu\text{m}/\text{turn}$ by default. When the model AZ100 is selected, it is set to 270 $\mu\text{m}/\text{turn}$. Other selections will set it to 100 $\mu\text{m}/\text{turn}$. This field can be fine tuned to correct for deviations in the calibration of the table movement.
Large Step Option	
Break large steps up in chunks of	Sets the maximum distance for a single motion when making a major change in position using the slider bar or direct entry in the edit box. Although motion is faster when this value is large, if the load to drive the motor is large, the motor may not rotate normally, making it impossible to move the specified amount. Conversely, the speed of motion is lower if a small value is used, but the error in distance of motion can be decreased.
Initial speed factor	Set the initial speed of RFA. The higher the value, the slower the speed. <ul style="list-style-type: none"> - Use this option for unusual stage loads. - For details, refer to the instruction manual of your RFA.
Acceleration factor	Set the acceleration speed of RFA. The higher the value, the slower the speed.

5.1.3 Z-scan tab

The Z-scan tab (Figure 5.1-2) is used to set the conditions of the Z-drive scanning. This tab contains the following controls:

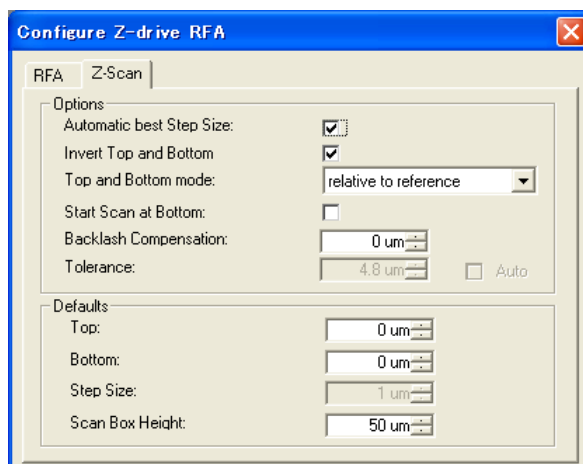

Figure 5.1-2 Z-Scan tab

Name	Function Overview
Options	
Automatic best Step Size	If this box is checked, the best step size is automatically calculated based on the resolution of the objective as specified under "Objective" on the "Configure" menu.
Invert Top and Bottom	Check this option if the direction of the movement of the microscope table and the position shown in the scan window are not the same. This may be necessary when the Z-drive is attached of the microscope in reverse.
Top and Bottom mode	This option is used to specify the format used when displaying the value for "Top" and "Bottom." A relative distance from the reference is used if "relative to reference" is selected for the "Top" and "Bottom" values, whereas if "absolute" is selected, just as with the "reference," an absolute distance from the position where the Z-drive started is used. There is no difference in operation.
Start Scan at Bottom	Check this option to start a 3D scan at the bottom instead of the top.
Backlash Compensation	<p>Use this function with automatic focusing control enabled to correct positioning errors resulting from backlashes caused by gear mechanisms. Enter a compensation value in the edit box in μm. The compensation value must be larger than any potential backlash value.</p> <ul style="list-style-type: none"> - The compensation value setting is available only with external units like the RFA drive unit or the E1000, whose mechanisms may result in backlash errors. No compensation feature is provided for the TE2000E autofocusing unit, which has a control function that prevents backlash. - For inverted microscopes, perform the 3D image acquisition by first using the lowest objective lens, and then upper ones. For upright microscopes, perform 3D image acquisition by moving the stage from the bottom to the top. In both cases, always move from lower to upper positions before setting the bottom position as scanning reference.
Tolerance	Specify the permissible deviation from the Z-position indicated on screen and the actual position observed by the microscope during 3D-image acquisition. Enter a value in the edit box in μm . (If RFA unit is connected to a manual microscope, this setting is disabled.)
Auto	Check this box to set automatically the tolerance to 1/7 of the optical resolution along the Z direction. (If RFA unit is connected to a manual microscope, this setting is disabled.)
Defaults	
Top	Specifies the default value for "Top." This option specifies a relative distance from the "Reference." Press the reset button to reset "Top" based on this value.
Bottom	Specifies the default value for "Bottom." This option specifies a relative distance from the "Reference." Press the reset button to reset "Bottom" based on this value.

Step Size	Specifies the default step size value. The step size is set to this value when the EZ-C1 begins operation. - If "Automatic best Step Size:" is checked, you can't change default step size because application set this parameter automatically.
Scan Box Height	This value specifies the maximum value allowable in the z-axis direction for the region displaying the scan range (the black square on the "Acquire Settings" window.) This is the maximum value which can be set for "Range."

5.2 Confocal C1 Settings

Nikon's C1 confocal microscope system (hereafter called the "C1") can obtain 3D images with a greater resolution than conventional microscopes. The C1 consists of a laser box, controller, detector, and scanhead attached to the photo port of the microscope.

For setup and installation of the entire C1 system, follow instructions given in the "Hardware Manual." This section describes the functions for setting up C1 hardware available on the "Configure Confocal C1" menu.

The "Configure Confocal C1" dialog box (Figure 5.2-1 - Figure 5.2-12) can be opened using the "Confocal C1" command on the "Configure" menu of the EZ-C1. This dialog box contains following pages.

5.2.1 Lasers tab

Set the laser parameters on this tab.

Lasers tabs for three-laser unit system and four-laser unit system are shown below.

For the three-laser unit system

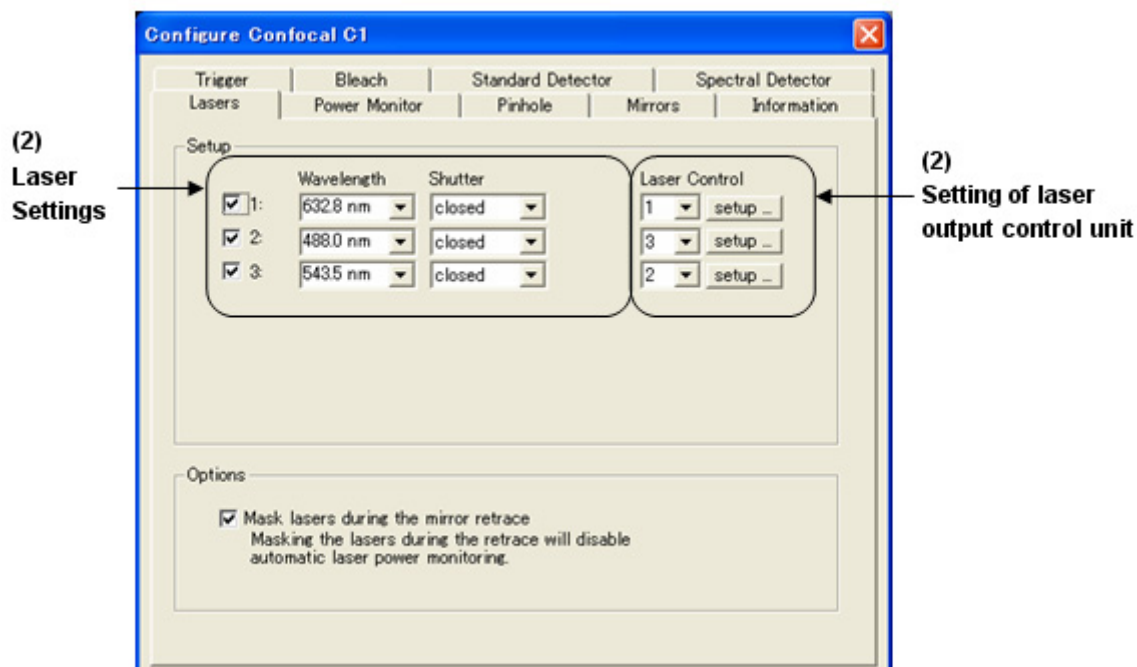

For the four-laser unit system

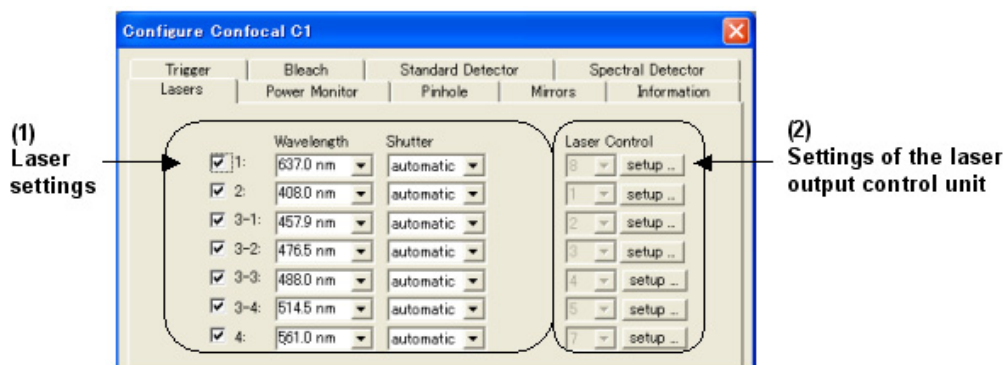

Figure 5.2-1 Lasers tab

Use these tabs (Figure 5.2-1) to make the following settings:

(1) Laser Settings

Use these settings to set the wavelength and other dialog settings of the laser.

Name	Function Overview
Check box	Select the check box for the laser you want to use. - In the Laser and Detector dialog box or the Laser Control Bar dialog box, you can only perform operation on the lasers selected here. Lasers not selected here cannot be used.
Wavelength	Set the wavelength of each selected laser.
Shutter	Set the opening and closing of the laser shutter. The Shutter settings are linked to those in the Laser and Detector dialog box. - automatic The shutter is automatically opened and closed. The shutter is opened when you start scanning and closed when you finish scanning. - open The shutter is opened. - close The shutter is closed. ! The shutter setting is disabled in the spectral mode. When the laser shutter settings described here have been made, go to the Laser and Detector dialog (see Section 3.2.1, "Detector Tab") and make the required settings there.
Mask lasers during the mirror retrace	Activates or deactivates shielding from the laser light during one-way scanning when the three-laser unit and AOM are connected, when moving the laser scanning point from the end point of a scan to the next start point (in the return path). ! When the four-laser unit is connected, this function is automatically deactivated.

(2) Laser output control unit (AOM/AOTF) settings

Set up the laser output control unit to be used with the laser.

Name	Function Overview
Laser Control	Set the laser output control unit number for each selected laser.

CAUTION
 - Under normal circumstances, the settings under [setup] should not be changed.

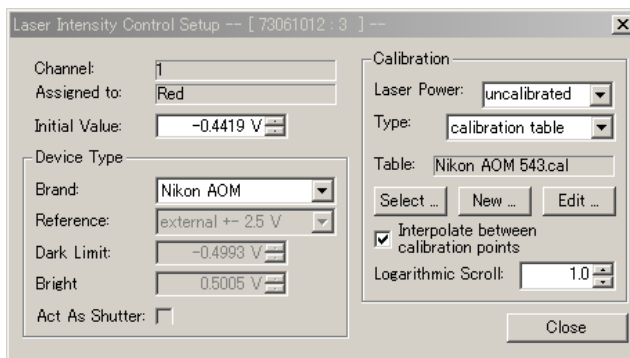

Figure 5.2-2 Laser Intensity Control Setup dialog box

Name	Function Overview
[setup]	Use this button to set details about each AOM. A dialog box titled “Laser Intensity Control Setup” (Figure 5.2-2) will be displayed.
Channel	Displays the laser output control unit number to be set.
Assigned to	Displays the name you entered in Name on the Laser tab.
Initial Value	Set the default laser power to be assumed when EZ-C1 starts.
Device Type Make settings for the laser output control unit.	
Brand	Set the type of laser or the type of laser output power control device.
Reference	Set the range of DAC reference input voltages.
Dark Limit	Set the lower-limit value of the DAC output voltage.
Bright	Set the upper-limit value of the DAC output voltage.
Act As Shutter	Specify this option when shutters are nonexistent and the laser is turned on and off in place of a shutter. When this option is selected, the laser output power is dropped to the lower-limit value as if a shutter were closed when the Shutter button (see 3.1) is closed from EZ-C1. (Applies only to lasers supporting this function)

Calibration	
For devices designed to adjust light intensity, since light intensity cannot be controlled in proportion to the set voltage, and since adjustment characteristics vary with each device, you can use this function to correct so that the light intensity will be controlled linearly when correction is set as a percent value.	
Laser Power	Set the unit of adjustment performed by the slider bar in the Laser Control Bar dialog box. The unit is displayed in the text box to the left of the slider bar. Uncalibrated: The set voltage is displayed. 100%: The light intensity value in the range that can be set by a device is displayed as a percent value. 10, 15, 20, 25 mv: The set value of light intensity in the 10, 15, 20, 25 mv range is displayed.
Type	Set the correction data. not calibrated: No correction data is used. calibration table: Correction data is used.
Table	Displays the currently set calibration table name when "calibration table" is selected for Type.
[Select]	Displays a list of calibration data tables that the currently set Brand has. Select one from this list.
[New]	Creates a new calibration data table.
[Edit]	Displays the currently selected calibration data table.
Interpolate between calibration points	When this check box is selected, the light intensity is adjusted by linear interpolation between the data points present in the calibration table. When this check box is unselected, the light intensity is adjusted solely on the basis of the data present in the calibration table.
Logarithmic Scroll	Set the Log scale.

5.2.2 Power Monitor tab

Set parameters relating to the Laser Power Monitor bar (see 3.8).

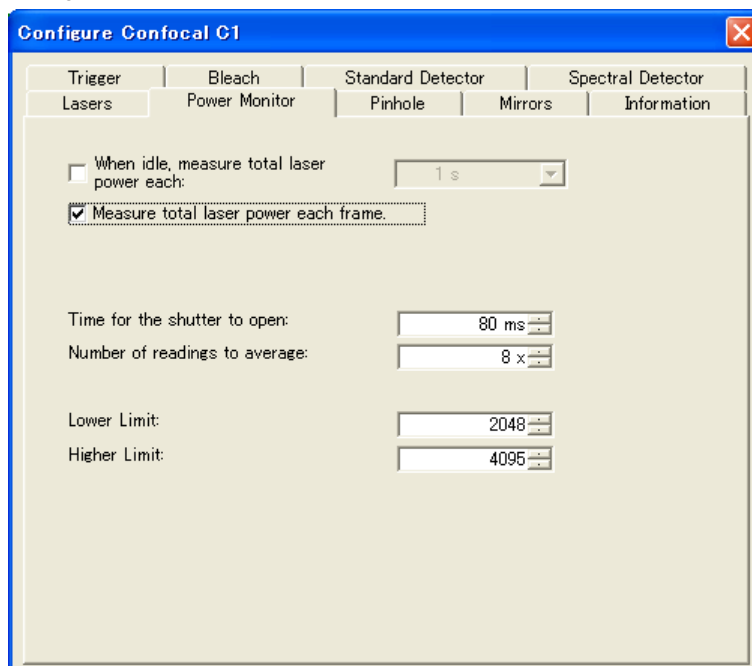

Figure 5.2-3 Power Monitor tab

Use the Power Monitor tab to make the following settings:

Name	Function Overview
When idle, measure total laser power each	Specify whether you want the laser output power to be periodically measured (by selecting the check box) and set measurement intervals (by entering in the list). ! When the four-laser unit system is used, this function is disabled.
Measure total laser power each frame	If this option is checked, the laser power monitoring value and the image at the start of scanning is shown in Description (see 4.1.9). ! When the four-laser unit system is used, this function is disabled.
Time for the shutter to open	Specify a time from when measurement started to when the shutter opens. More specifically, this is the wait time before measurement actually starts after a measurement operation command is first issued (i.e., the Measure button in the Laser Power Monitor bar (see 3.8) is pressed or the interval time specified in "Measure Tools Power each" has elapsed).
Number of readings to average	Specify the number of measurements to be performed whose values you want to average. The value displayed in the Laser Power Monitor bar (see 3.8) is averaged from multiple measurements performed as specified here.

Lower Limit	Specify the lower-limit value to be measured in the Laser Power Monitor bar (see 3.8). Signals whose measured laser power is below this value are marked by “Under.” Normally, specify 2048, which is the lower-limit value of the laser power monitor.
Higher Limit	Specify the upper-limit value to be measured in the Laser Power Monitor bar (see 3.8). Signals whose measured laser power is above this value are marked by “Over.” Normally, specify 4095, which is the lower-limit value of the laser power monitor.

5.2.3 Pinhole tab

Use this function to make pinhole settings.

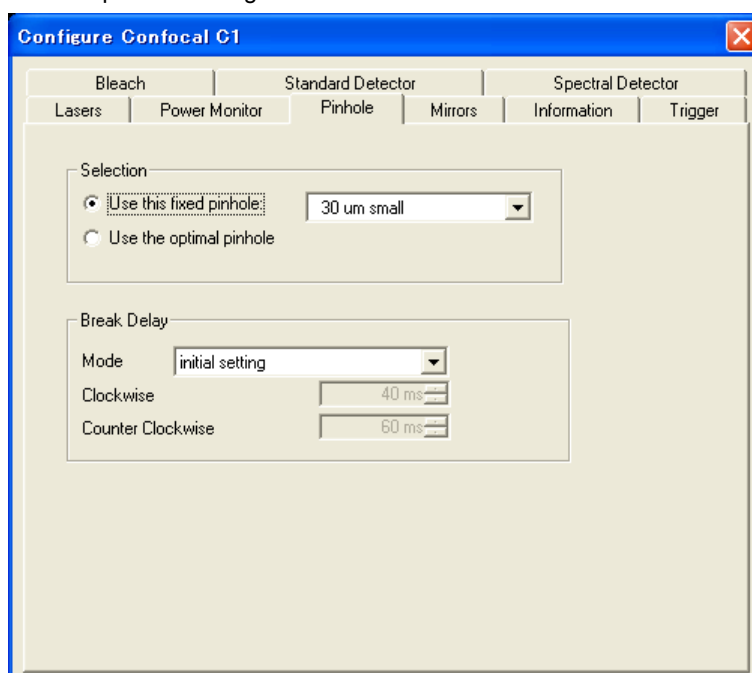

Figure 5.2-4 Pinhole tab

Name	Function Overview
Selection	Selects whether automatic or manual control should be used to control the size of the pinhole.
Use this fixed pinhole	Manually controls the size of the pinhole.
Use the optimal pinhole	The application automatically controls the size of the pinhole. This is coordinated with the objective.
Break Delay	Selects the timing for applying the break when the pinhole is rotating.

Mode	Select whether you want to use the initial factory setting for the “Break Delay” value or if you want freely specify a value instead. When using the initial setting, adjustment values already input to the controller are used. If a manual setting is used, it is possible to set a “Delay” value in the field below. Use the manual setting if the pinhole does not stop at the correct position when using the initial setting value. It is necessary to restart the controller in order to return from using a manual setting to using the initial setting.
Clockwise	Gives the timing when the pinhole is rotating clockwise. Specifies the time to apply the break after the pinhole starts rotating.
Counter Clockwise	Gives the timing when the pinhole is rotating counterclockwise. Specifies the time to apply the break after the pinhole starts rotating.

5.2.4 Mirrors tab

Use this tab to set details about the mirror in the C1 scan head.

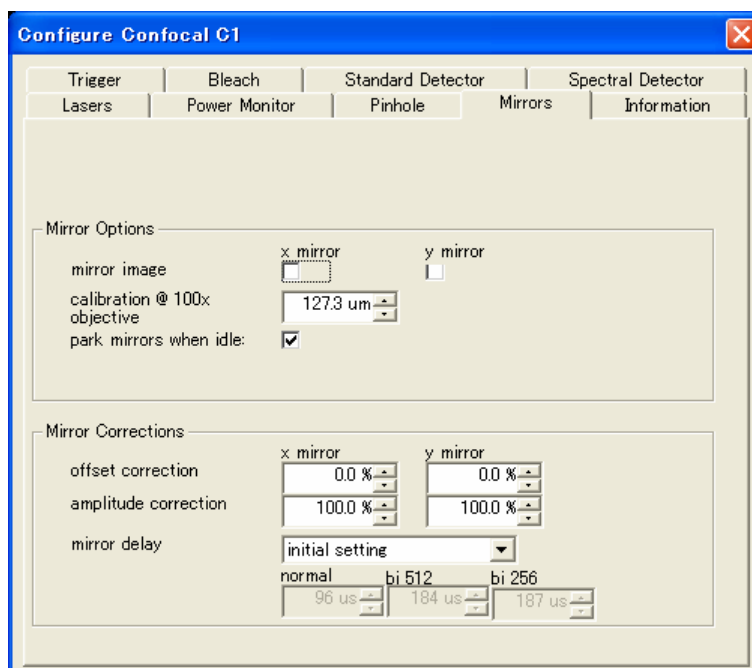

Figure 5.2-5 Mirrors tab

Name	Function Overview
Mirror Options	
mirror image	Setting this option lets you perform reversed scanning. Use this option when images are reversed while (for example) using an inverted microscope.
x mirror	The start and end points of scan and the direction of scan in the x direction are reversed.

y mirror	The start and end points of scan and the direction of scan in the y direction are reversed.
calibration@100xobjective	This is the field of view observed using a 100x objective and a maximum zoom range. The scale for the field of view is determined based on the calibration value and objective information (Object list in Acquire Settings dialog box, described in 4.2.3).
park mirror when idle	Use this option to move the mirror to its escape position after scanning has stopped. The sample will not be exposed to laser light. If this option is unselected, the mirror does not move after scanning has stopped. The sample will be exposed to laser light while opening the shutter.
Mirror Corrections - Do not alter the Mirror Corrections value.	
offset correction	Corrects the scanning position. The scanning position cannot be moved when amplitude correction = 100%.
amplitude correction	Alters the size of the scanning area.
mirror delay	Sets a wait time per line before scanning starts in regular, bi-directional, and fast scanning. Select "initial setting" from the combo box to set the default value that C1 controller has in text box for a wait time before each scanning. Select "manual setting" from the combo box to enter a value in text box for a wait time before each scanning. The entered wait time settings are stored in EZ-C1 and set in the next and subsequent operations.

5.2.5 Information tab

Use this tab to view firmware version, the IP address of connected hardware and other information.

Controller IP address = 192.168.255.254

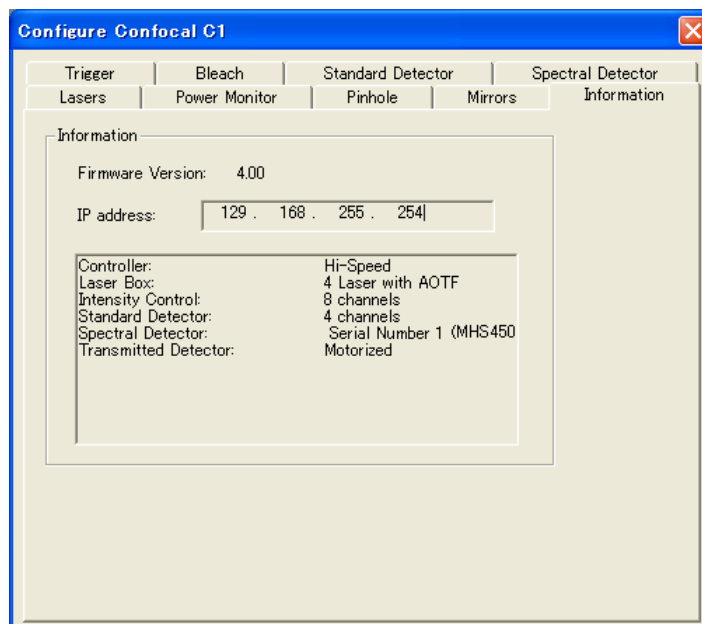

Figure 5.2-6 Information tab

This tab contains following items.

Name	Function Overview
Firmware Version	Shows the C1 firmware version.
IP address	Shows the IP address of the C1 controller used for communications with the C1 controller.
List	Shows a list of the following hardware. <ul style="list-style-type: none"> - Controller: Information of the scanner Hi-Speed (High speed scanner is installed.) / Standard (Standard scanner is installed.) - Laser Box: Information of the laser unit and brightness control device 4Laser with AOTF (Four-laser unit is installed.) / 3Laser with AOM (Three-laser unit and AOM are installed.) / 3Laser (Three-laser unit is installed.) - Intensity Control: Information of the NI Card 8channels (NI6713 board is installed.) / 4channels (NI6711 board is installed.) - Standard Detector: Information of the standard detector 4channels (Two grabber boards are installed.) / 3 channels (One grabber board is installed.) - Spectral Detector: Information of the spectral detector unit (order number) - Transmitted Detector: Information of the transmission detector Motorized (Motorized transmission detector is installed.) / Manual (Standard transmission detector is installed.) / None (No transmission detector is installed.)

5.2.6 Trigger tab

Use this function to make trigger settings.

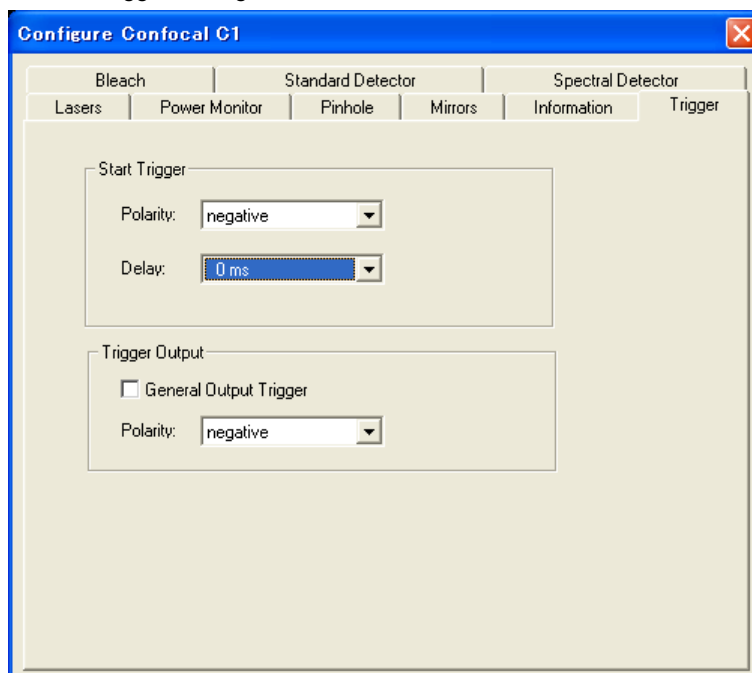

Figure 5.2-7 Trigger tab

The following items are found on the “Trigger” tab.

Name	Function Overview
Start Trigger This option sets the timing for taking a photo image based on the input of a trigger signal.	
Polarity	Specifies which level of the input signal should be used as the trigger signal. When “positive” is set, the maximum value is used as the signal. When “negative” is set, the minimum value is used as the signal.
Delay	Specifies the time delay from the point the trigger signal input is detected until image acquisition begins.
Trigger Output This option sets the trigger signal to be output.	
General Output Trigger	Setting this option outputs the trigger signal. The signal is output when the frame scan starts. (The signal is output in each frame in the Live scan mode. When Start Trigger is set to ON, the signal is output at scan start after the delay time has passed.)
Polarity	Specifies which level should be output as a signal. When “positive” is set, the maximum value for the output level is used as the signal. When “negative” is set, the signal results when the level drops from its maximum to minimum value.

5.2.7 Bleach tab

Set parameters relating to Bleach.

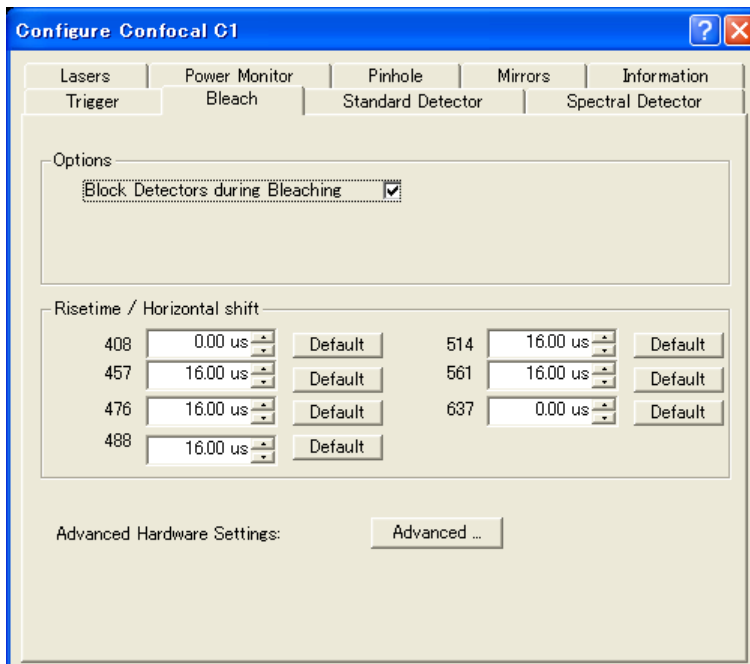

Figure 5.2-8 Bleach tab

Use the Bleach tab to make the following settings:

Name	Function Overview
<p>Block Detectors during Bleaching</p>	<p>If this box is checked, gain is automatically set to “0” when performing only the bleach step as part of a sequence. If this box is unchecked, gain is never changed; The user-specified gain value is used instead. <Image display while performing the Bleach step as a part of a sequence> EZ-C1 actively switches off the gain voltage supply when incidence laser intensity significantly increases. When performing the bleach step as part of a sequence, check “Block Detectors during Bleaching” on the Bleach tab in the Configure dialog box to automatically set the gain to “0” to prevent a loss of the gain voltage. The image is not displayed during bleaching.</p>
<p>Risetime/Horizontal shift</p>	<p>Set the delay time until laser power reaches a set value in response to the NI card output for each laser set in the Lasers tab.</p>
<p>[Default]</p>	<p>Press this button to set the default delay time for the laser.</p>
<p>[Advanced Hardware Settings]</p>	<p>Pressing this button displays the Analog Out Advanced Options dialog box (Figure 5.2-9), which lets you set up the NI-DAQ card (one that is inserted into the PC to control the laser output power).</p> <ul style="list-style-type: none"> - Under normal circumstances, the following settings should not be changed.

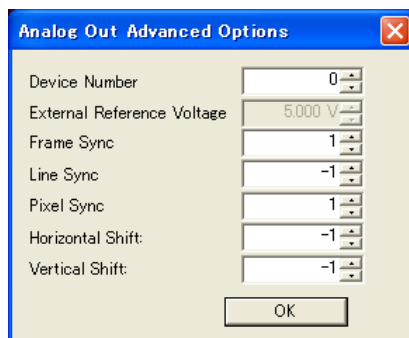

Figure 5.2-9 Analog Out Advanced Options dialog box

Use the Analog Out Advanced Options dialog box to make the following settings:

Name	Function Overview
Device Number	Set the device number used for the card in EZ-C1. Normally, "1" is set for this entry.
External Reference Voltage	Set the input signal voltage to be referenced from outside the card. When using the Nikon AOM, "2.5 V" is set for this entry.
Frame Sync, Line Sync, Pixel Sync	Set the synchronizing signal for each. For "C1", "1", "-1", and "1" are set for these entries, from top to bottom.
Horizontal Shift	Set a variable in the horizontal direction needed for the spots in the Live window and the bleach areas to be synchronized. Normally, "-1" is set for this entry. ("-2" is set for the three-laser unit system.)
Vertical Shift	Set a variable in the vertical direction needed for the spots in the Live window and the bleach areas to be synchronized. Normally, "-1" is set for this entry.

5.2.8 Standard Detector tab

Use these settings to make settings for the standard detector PMT output data.

Association between PMT output data and barrier filter of the standard detector is indicated by lines in wavelength colors.

When transmission detector data is acquired, its association is also indicated by lines.

Note

- When a grabber board is installed, three channels can be set in Number of Channels. Then select a channel to output PMT2 or DIC data in the Laser and Detector dialog box.
- When two grabber boards are installed, four channels can be set in Number of Channels.

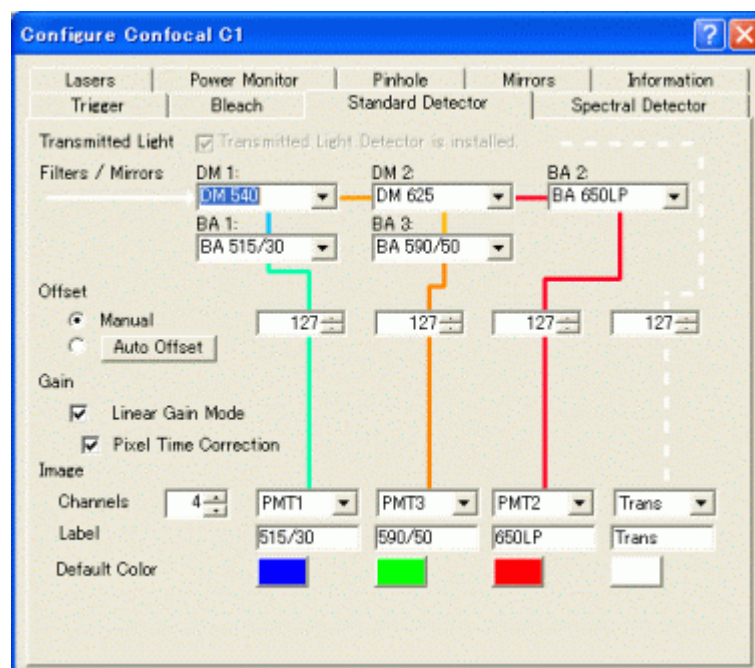

Figure 5.2-10 Standard Detector tab

Name	Function Overview
Transmitted Light:	Indicates whether a transmitted detector is mounted.
Transmitted Detector is installed	<p>Select this checkbox when a transmitted detector is installed. Trans appears in each Order menu and DIC output data can be assigned to EZ-C1 channels.</p> <p>! This checkbox is grayed out and automatically selected when a motorized transmitted light detector is installed.</p> <p>! Please be sure to check that a transmitted illumination lamp is OFF before setting a Transmitted Light Detector to IN.</p>
Filters/Mirrors:	Registers the filter cube wavelength. The settings are written in the ics file.
DM 1, 2	Specify wavelengths of dichroic mirrors.
BA 1, 2, 3	Specify wavelengths of barrier filters.



Offset Specifies for each channel the offset value to use for the voltage output from the photo multiplier.	
Manual	Set this function to maintain a constant gain level regardless of the voltage output by the photo multiplier.
Auto Offset	Sets the offset values for PMT output voltage based on the PMT Calibration data created by the Offset Calibration function. The C1 Offset Calibration dialog box opens if PMT calibration data has not been created yet.
[Auto Offset]	<p>Press the [Auto Offset] button to open the C1 Offset Calibration dialog box. Here, press the [Start] button. For all PMTs excepting one for the transmission detector, the offset values for PMT output voltage are measured by adjusting gain and pixel dwell, until a calibration table is created.</p> <p>! Incident light to the PMT must be blocked when creating this calibration table. Before creating the calibration table (pressing the [Start] button), turn off the light in the room, so that the measurement is performed in the dark.</p> <p>! The offset value for PMT output voltage of the transmission detector can only be adjusted manually. It cannot be adjusted automatically by the Offset Calibration function.</p> 
Gain	
Linear Gain Mode	The relationship between gain level and actual gain is indicated by logarithmic graph. Gain varies by approximately 10x when the level is changed by 1. <u>Note that, when having removed the check mark from the checkbox and restored the normal Gain mode, the value displayed changes to "0," but the original setting remains. This is not an error. You can continue to adjust the Gain.</u> However, this mode cannot be invoked for a channel set to Trans (transmission detector). ! When this mode is on, gain values on the gain bar are indicated as logarithmic values (for example, 0.15B = $10^{0.15}$ and 5.0B = $10^{5.0}$).
Pixel Time Correction	Check this option to adjust the gain so that uniform brightness is achieved for "Period." When the laser scanning speed is changed, a different amount of light than during the integration period is obtained. The observed brightness varies as a result. Check this option to automatically adjust the PMT gain compensates for fluctuations in image brightness.

Figure 5.2-11 C1 ADC Offset Calibration dialog box

Image	
 <p>Channel count</p>  <p>Channel assignment</p>	<p>Channel count: Specify the channel count to be used.</p> <p>Channel assignment: When a grabber board is installed and the standard mode is used, channels of EZ-C1 can be assigned for PMT output data or DIC output data. (PMT 1, 2, 3, or Trans) Channel 1, 2, 3, and 4 of EZ-C1 are placed from left to right. Assign PMT 1, 2, 3, and Trans to these channels.</p> <ul style="list-style-type: none"> - If these settings are changed, the layout of the channel display on the Gain Bar dialog box is changed. (See 3.3.)
<p>Label</p>	<p>Set a label name for each channel data. The band pass filter wavelength of PMT output data are set by default.</p> <ul style="list-style-type: none"> - This label name appears on the Gain bar and on the detector buttons on the Laser and Detector dialog box.
<p>Default Color</p>	<p>Use to set the default PMT data display color.</p> <p>! The colors set here become the “green-red-blue-DIC” default color list settings in the View Settings dialog box Color tab.</p>

5.2.9 Spectral Detector tab

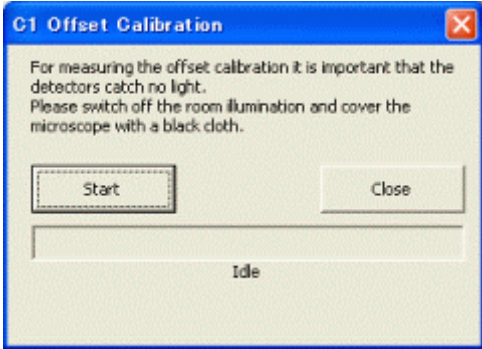

Use this tab to perform brightness calibration for the spectral detector.

CAUTION

<Brightness calibration>

Brightness calibration involves transmission correction (tube, first dichroic mirror, objective lens and scan head) and correction of the spectral responsivity of the spectral detector.

To perform brightness calibration, make the following settings in the Spectral Detector tab.

- Use Confocal BS 20/80 as the Dichroic Mirror (first dichroic mirror).
 - Install a spectral lens (a lens with the  symbol) from [Objectives] (objective lens).
 - : a spectral objective lens (supporting transmission correction and brightness calibration)
- Brightness calibration is not performed with objective lenses other than the above type.

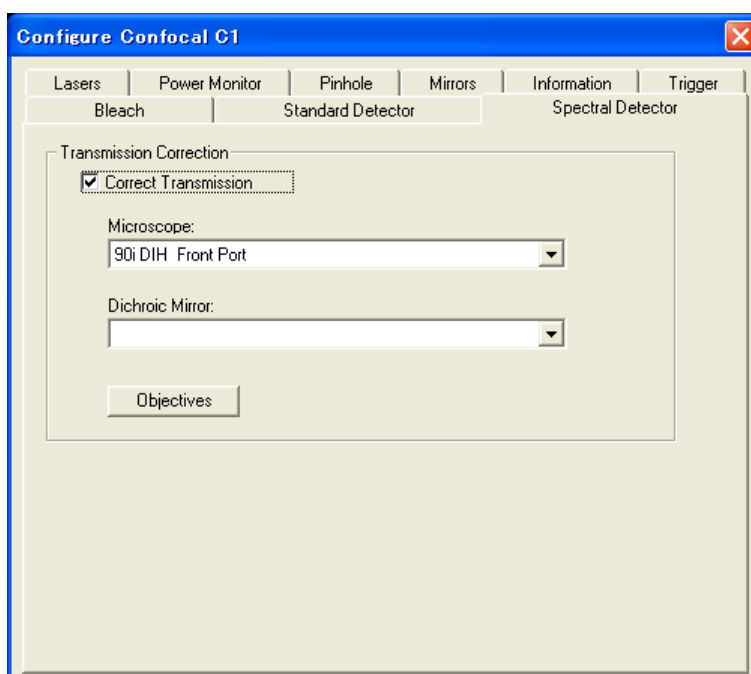

Figure 5.2-12 Spectral Detector tab

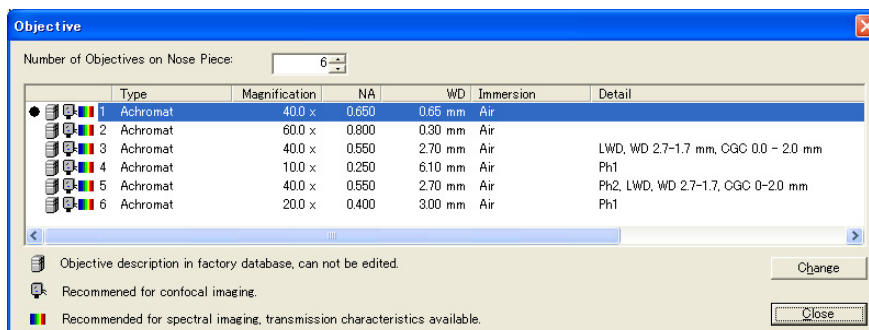

Figure 5.2-13 Objective dialog box

Name	Function Overview
Correct Transmission Checkbox	When checkbox is selected: Brightness calibration is performed. When checkbox is deselected: Brightness calibration is not performed.
Microscope	Select the microscope to be used.
Dichroic Mirror	Set the first dichroic mirror to be used. ! Select Confocal BS 20/80 as brightness calibration will otherwise not be performed.
[Objectives]	Select objective lens. ! Install a spectral objective lens (supporting transmission data and brightness calibration). Brightness calibration is not performed with a non-spectral objective lens.

5.3 Microscope Ti

The EZ-C1 supports Ti microscopes, offering the capabilities of operating the Z-drive and selecting an objective nosepiece.

To operate the Ti microscope from the EZ-C1, the Ti Control Software must be installed (refer to the “Software for Inverted Microscope Ti, Ti Control” for details). Once the Ti Control Software is installed, the Configure Devices dialog box includes an additional item, shown as “Microscope Ti-E.”

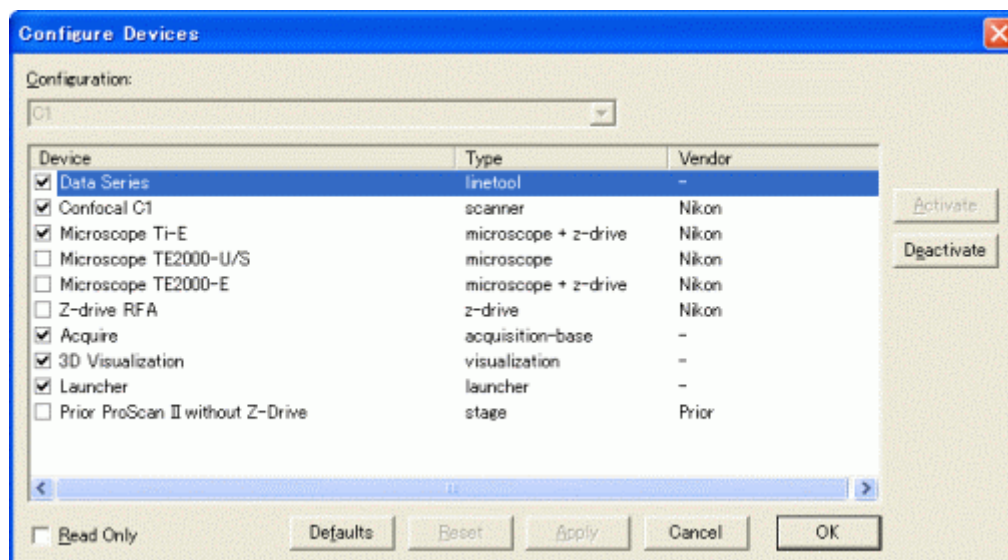

Figure 5.3-1 Configure Device dialog box

Specific control items depend on whether the HUB-A and other optional devices are connected. (For example, if HUB-A is connected, shutters and filters can be controlled with the confocal mode function. They cannot be controlled without HUB-A.)

From the Configure menu of the EZ-C1, select “Microscope Ti-E” to open the Configure Microscope Ti-E dialog box. This dialog box allows you to view the status of communications/connections to the Ti microscope, as well as to configure the XY stage and Z-drive.

Note

- The following considerations should be noted in case of registering new objective information which is not originally provided in the Ti microscope (i.e., not included in the list displayed via Devices | Objective | Change).
 - If new objective lens information is registered from the Ti Control Pad, it is updated only at the time of EZ-C1 startup. Therefore, any information registered from the Ti Control Pad during operation of EZ-C1 is not updated in the EZ-C1. New information should be registered before starting the EZ-C1.
 - If new objective lens information is registered from the Ti Control Software, it will be updated also during operation of EZ-C1.
- Changing the Z position significantly in Ti via the EZ-C1 may make the communications unstable. We recommend operation with the Ti microscope when changing the Z position significantly.

5.3.1 Ti Tab

Use the Ti tab (Figure 5.3-2) configure information specific Ti.

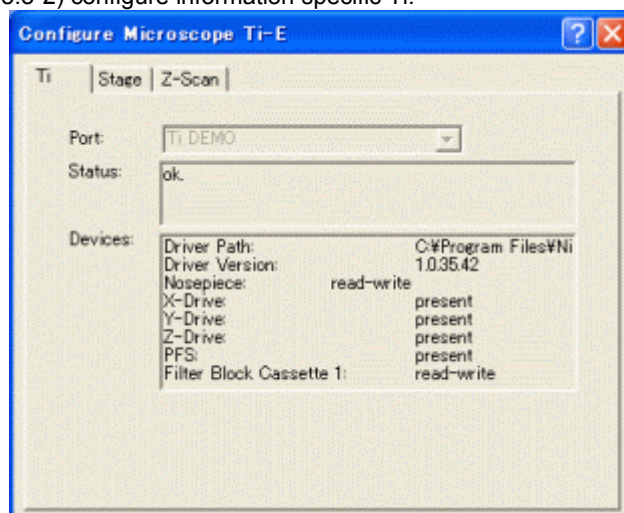

Figure 5.3-2 Ti tab

The parameters are defined as follows:

Name	Function overview
Port	Selects the USB port desired for connection to the Ti.
Status	Normal operation is indicated as "ok."
Devices	Displays the connections to the nosepiece, Z-drive, XY stage, etc.

5.3.2 Z-Scan Tab

Use the Z-Scan tab (Figure 5.3-3) to configure Z-axis scanning. The parameters are defined as follows:

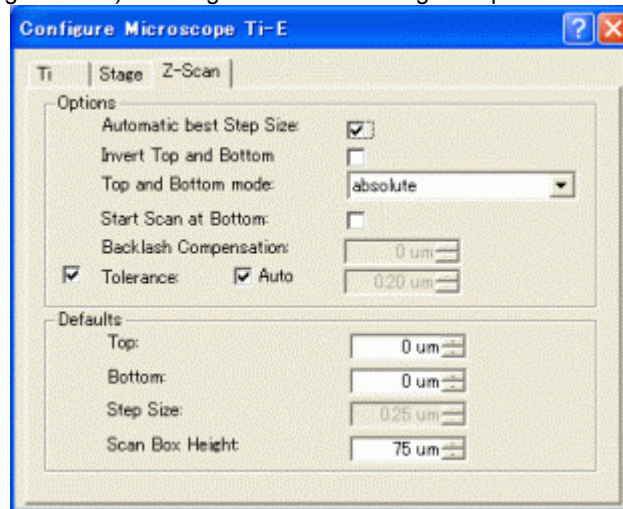

Figure 5.3-3 Z-Scan tab

Name	Function overview
Options	
Automatic best Step Size	If this box is checked, the best step size is automatically calculated based on the resolution of the objective as specified under “Objective” on the “Configure” menu.
Invert Top and Bottom	Check this option if the direction of the movement of the microscope table and the position shown in the scan window are not the same. This may be necessary when the Z-drive is attached to the microscope in reverse.
Top and Bottom mode	This option is used to specify the format used when displaying the value for “Top” and “Bottom.” A relative distance from the “Reference” is used if “relative to reference” is selected for the “Top” and “Bottom” values. If “absolute” is selected, just as with the “Reference,” an absolute distance from the position where the Z-drive started is used. There is no difference in operation.
Start Scan at Bottom	Check this option to start a 3D scan at the bottom instead of the top.
Backlash Compensation	Use this function with automatic focusing control enabled to correct positioning errors resulting from backlashes caused by gear mechanisms. Enter a compensation value in the edit box in μm . The compensation value must be larger than any potential backlash value. <ul style="list-style-type: none"> - The compensation value setting is available only with external units like the RFA drive unit or the E1000, whose mechanisms may result in backlash errors. No compensation feature is provided for the autofocus unit of Ti microscope, which has a control function that prevents backlash.

Tolerance	If this box is checked, specify the permissible deviation between the Z-position indicated on screen and the actual position observed by the microscope during 3D-image acquisition. Enter a value in the edit box in μm . If this box is not checked, the Z-position error check is disabled.
Auto	If this box is checked, the tolerance is automatically set to the best value.
Defaults	
Top	Specifies the default value for "Top." This option specifies a relative distance from the "Reference." Press the reset button to reset the "Top" value based on this value.
Bottom	Specifies the default value for "Bottom." This option specifies a relative distance from the "Reference." Press the reset button to reset the "Bottom" value based on this value.
Step Size	Specifies the default step size value. The step size is set to this value when the EZ-C1 begins operation. - If "Automatic best Step Size:" is checked, you cannot change the default step size because the application sets this parameter automatically.
Scan Box Height	This value specifies the maximum value allowable in the Z-axis direction for the region displaying the scan range (the black square in the "Acquire Settings" window.) This is the maximum value which can be set for "Range."

5.3.3 Stage Tab

Use the Stage tab to configure various settings for XY stages. The parameters are defined as follows:

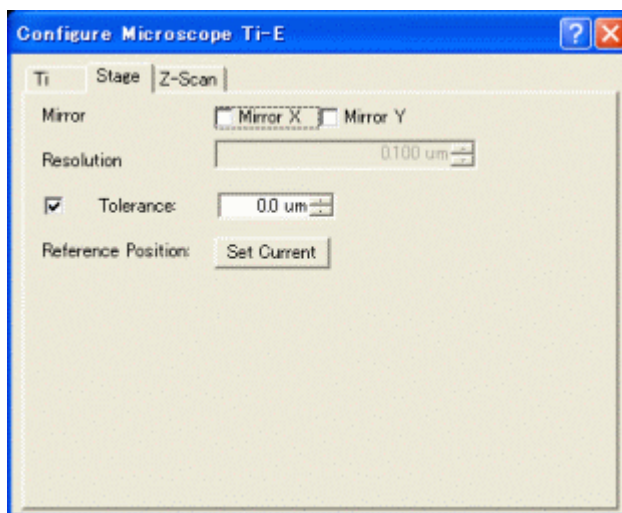

Name	Function overview
Mirror	
Mirror X	Inverts the left and right coordinate information for stage movement.

Mirror Y	Inverts the forward and backward coordinate information for stage movement.
Resolution	Sets the level of resolution for stage movement. It is fixed to 0.1 μm when the Ti-E is connected.
Tolerance	When this box checked, specify the permissible deviation between the XY position indicated on screen and the actual position observed by the microscope. Enter a value in the edit box in μm . If this box is not checked, the Z-position error check is disabled.
Reference Position	Sets the reference position for displaying the stage position. [Set Current]: Uses the current position as the reference position.

5.3.4 Perfect Focus System Bar

If a motorized nosepiece with PFS is connected, the Tools menu has a Perfect Focus System Bar added to it. Select "Perfect Focus System Bar" to display the following dialog box:



Name	Function overview
[PFS]	Select the perfect focus system operation. <input checked="" type="checkbox"/> [PFS] : The perfect focus system is in focusing. <input type="checkbox"/> [PFS] : The perfect focus system is on standby. <input checked="" type="checkbox"/> [PFS] : The offset value has been set.
Status field	The control status for focusing is displayed here. [OK]: The focusing control is enabled. [OFF]: The focusing control is disabled. [Moving]: The focusing position search is in progress. [Objective Error]: The selected objective is not applicable. [Search Error]: An error occurred in searching the focusing position.
Offset value	The offset value is displayed here.
Offset value adjustment bar	Move the scroll bar to adjust the offset value.

Note

1. If one of "Top," "Bottom," or "Index" is selected on the Z-Stack tab in the focusing control, the view of the [PFS] button changes to **[PFS]**.
2. When the [PFS] button is displayed as **[PFS]** and the [PFS] button is pressed or "Ref" is selected, the focusing control starts and the view of the [PFS] button changes to **[PFS]**.

5.3.5 Stage Tools Bar

To display the Stage dialog box, select Stage in the Tools menu. The EZ-C1 can be used to control the XY stage.

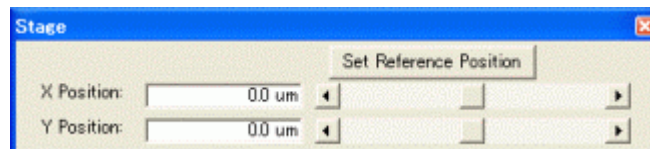

Name	Function overview
[Set Reference Position]	Uses the current position as the reference position. The stage position is expressed relative to the reference position.
X Position	Moves the stage in the X direction. The arrow keys at the ends cause fine movement: 1.0 μm with each click. Clicking in the scroll area causes coarse movement: 40.0 μm each.
Y Position	Moves the stage in the Y direction. The arrow keys at the ends cause fine movement: 1.0 μm with each click. Clicking in the scroll area causes coarse movement: 40.0 μm each.

5.3.6 Ti Bar

The Ti bar is displayed if the Ti Control software is installed.

The Ti bar contains the confocal mode button:



Name	Function overview
 Confocal mode button	This button sets the optical path, filters, diascopic illumination lamp, diascopic illumination shutter, and episcopic illumination shutter to cater for confocal microscopy. (If HUB-A is not connected, however, only the optical path is changed.)

5.4 Microscope TE2000

You can use EZ-C1 to operate the TE2000 Z-drive and to select objective revolvers.

Besides, you can use EZ-C1 to operate the Nikon perfect focus system. (For details, refer to “TE2000 PERFECT FOCUS SYSTEM manual.”) You can use the perfect focus system with the TE2000-E to control the focus automatically.

To operate the TE2000 from the EZ-C1, install the TE2000 Control. (For more information, refer to the manual “TE2000 Control Software for TE2000 Inverted Microscope.”) Installing TE2000 Control adds [Microscope TE2000-U/S] and [Microscope TE2000-E] to the registration list of Configure Devices.

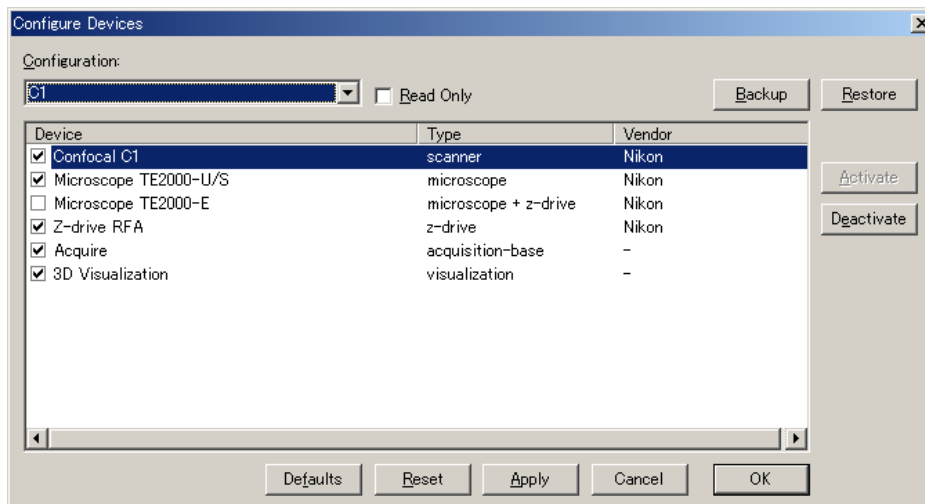

Figure 5.4-1 Configure Device Dialog Box

The TE2000-U/S does not have a Z-drive, which is the only difference from the TE2000E. When TE2000-U/S is selected, therefore, the Z-drive RFA is turned on automatically. (It can be then manually turned off.)

The Configure TE2000-E dialog box and the Configure TE2000-U/S dialog box appear when you select the Microscope TE2000-E and Microscope TE2000-U/S menu, respectively from the EZ-C1’s Configure menu. Each dialog box contains the same items.

In the dialog box, enter settings related to communications with the TE2000 and settings associated with Z-Drive.

CAUTION

- To operate the perfect focus system, the latest version of TE2000 Control software must be installed. Install the TE2000 Control software provided in the EZ-C1 installation CD.

Note

- Changing objective information from the control pad, etc., while EZ-C1 is up and running may destabilize communications between the TE2000 and EZ-C1. Always close EZ-C1 before changing objective information.
- Making significant changes from EZ-C1 in the Z position of the TE2000 may destabilize communications. We recommend making any significant changes in Z position from the TE2000 itself.

5.4.1 TE2000 tab

The TE2000 tab (Figure 5.4-2) is used to specify TE2000-specific information.

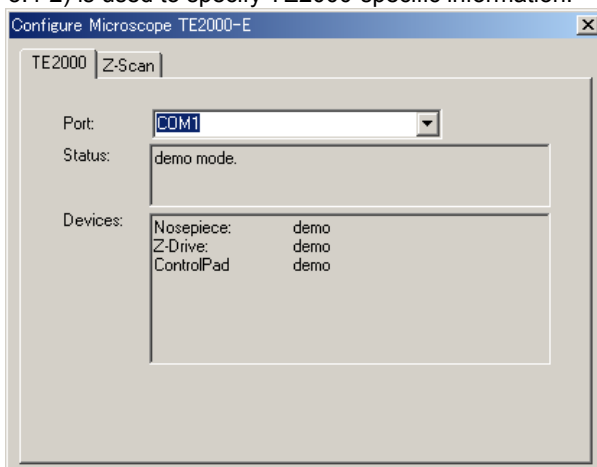

Figure 5.4-2 TE2000 tab

Each of the parameters has the following meaning:

Name	Function Overview
Port	The serial port to which the RFA port is connected. COM1 or COM2 can be selected from the list.
Status	“OK” is displayed while the system is running normally.
Devices	Displays nosepiece, Z-Drive, and ControlPad connection statuses.

Note

- **When “Microscope TE2000-U/S” is selected in the Configure Devices dialog box**
 When the Microscope TE2000-U/S check box is activated in the Configure Devices dialog box (the dialog box displayed by selecting Device from the Configure menu), perform Z-drive settings by selecting the Z-Drive RFA of the Configure menu.

5.4.2 Z-Scan tab

The Z-Scan tab (Figure 5.4-3) is used to set the conditions of the Z-drive scanning. This tab contains the following controls:

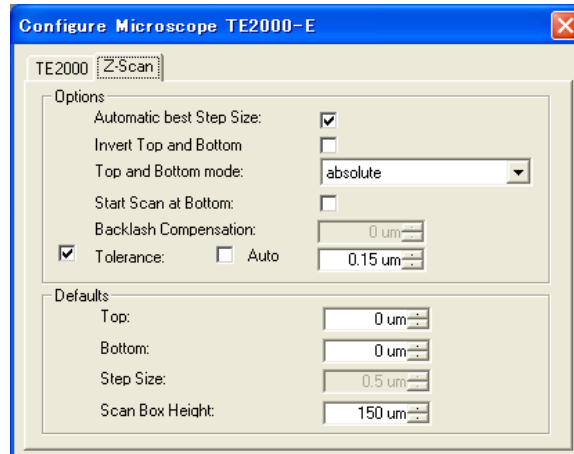

Figure 5.4-3 Z-Scan tab

Name	Function Overview
Options	
Automatic best Step Size	If this box is checked, the best step size is automatically calculated based on the resolution of the objective as specified under “Objective” on the “Configure” menu.
Invert Top and Bottom	Check this option if the direction of the movement of the microscope table and the position shown in the scan window are not the same. This may be necessary when the Z-drive is attached of the microscope in reverse.
Top and Bottom mode	This option is used to specify the format used when displaying the value for “Top” and “Bottom.” A relative distance from the reference is used if “relative to reference” is selected for the “Top” and “Bottom” values, whereas if “absolute” is selected, just as with the “reference”, an absolute distance from the position where the Z-drive started is used. There is no difference in operation.
Start Scan at Bottom	Check this option to start a 3D scan at the bottom instead of the top.
Backlash Compensation	Use this function with automatic focusing control enabled to correct positioning errors resulting from backlashes caused by gear mechanisms. Enter a compensation value in the edit box in μm . The compensation value must be larger than any potential backlash value. <ul style="list-style-type: none"> - The compensation value setting is available only with external units like the RFA drive unit or the E1000, whose mechanisms may result in backlash errors. No compensation feature is provided for the TE2000E autofocusing unit, which has a control function that prevents backlash.

Tolerance	Select this check box to specify the maximum permissible error between the Z position displayed on screen and the position read out from the microscope during 3D-image acquisition. Enter this permissible error margin in the edit box in μm units. Z-position errors are not verified if this box is unselected. - This function is available only with the TE2000 firmware version (both Hub main and Hub sub) of Ver 2.10 or later. (To check the firmware version, refer to the TE2000 instruction manual.) In all earlier versions, Tolerance is always enabled .
Auto	Select this check box to set the optimum Tolerance value automatically.
Defaults	
Top	Specifies the default value for "Top." This option specifies a relative distance from the "Reference." Press the reset button to reset "Top" based on this value.
Bottom	Specifies the default value for "Bottom." This option specifies a relative distance from the "Reference." Press the reset button to reset "Bottom" based on this value.
Step Size	Specifies the default step size value. The step size is set to this value when the EZ-C1 begins operation. - If "Automatic best Step Size." is checked, you can't change default step size because application set this parameter automatically.
Scan Box Height	This value specifies the maximum value allowable in the z-axis direction for the region displaying the scan range (the black square on the "Acquire Settings" window.) This is the maximum value which can be set for "Range."

5.4.3 TE2000 bar

The TE2000 bar is displayed when TE2000 Control is installed in your system. The TE2000 bar is a toolbar. To display it, use the TE2000 command from the EZ-C1 Tools menu. The TE2000 bar contains the button shown below.



TE2000 start button; it is used to start the TE2000 control application.

5.4.4 Perfect Focus System Bar

When the perfect focus system is installed with the system, the Perfect Focus System Bar appears on the Tools menu. Select the Perfect Focus System Bar to show the following dialog box.



Name	Function Overview
[PFS]	Select the perfect focus system operation. : The perfect focus system is in focusing. : The perfect focus system is on standby. : The offset value has been set.
Status field	The control status for focusing is displayed here. [OK]: The focusing control is enabled. [OFF]: The focusing control is disabled. [Moving]: The focusing position search is in progress. [Objective Error]: The selected objective is not applicable. [Search Error]: An error occurred in searching the focusing position.
Offset value	The offset value is displayed here.
Offset value adjustment bar	Move the scroll bar to adjust the offset value.

Note

1. If one of "Top," "Bottom," or "Index" is selected on the Z-Stack tab in the focusing control, the view of the [PFS] button changes to . This is a status that the perfect focus system is not in focusing but only the offset value is set.
2. When the [PFS] button is displayed as and the [PFS] button is pressed or "Ref" is selected, the focusing control starts and the view of the [PFS] button changes to .

5.5 Microscope i-Series (90i, 80i)

EZ-C1 enables Z-drive operation of the i-series of microscope. It also lets the user select an address of the objective nosepiece or switch to any predetermined group of settings for microscope status. Before operating the i-series of microscope from the EZ-C1, the i-Control must be installed in your system. (For more information, refer to the “i Series Support Tools Software Manual” for the ECLIPSE-i series of microscopes.) Installing i-Control adds “Microscope 90i” and “Microscope 80i” to the Configure Devices dialog box.

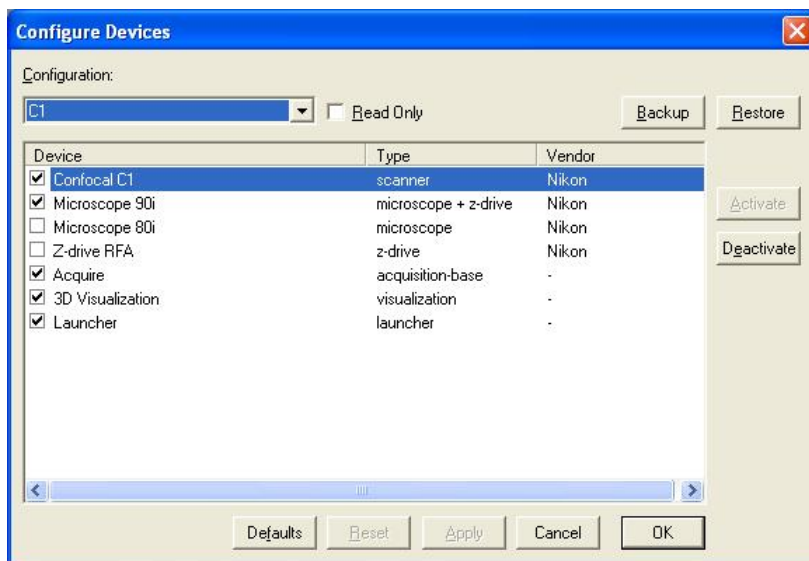

Figure 5.5-1 Configure Devices dialog box

Because 80i Microscope does not have built in Z-Drive, Z-Drive RFA will be selected automatically. Select Microscope 90i from the EZ-C1 Configure menu to display the Configure Microscope 90i dialog. Select Microscope 80i to display the Configure Microscope 80i dialog. Use this dialog to configure the communications with the Ti series microscope, display connection status, and set Z-Drive.

CAUTION

- To operate the i series microscope, the latest i Series Support Tools software must be installed. Install the i Series Support Tools software provided in the EZ-C1 installation CD.
- EZ-C1 does not support the motorized epi illuminator D-FL-E. Therefore, do not use the 80i and D-FL-E with EZ-C1.

5.5.1 90i tab, 80i tab

Use the 90i tab (Figure 5.5-2) to set information specific to the 90i. When it connects with 80i, it is displayed as 80i tab.

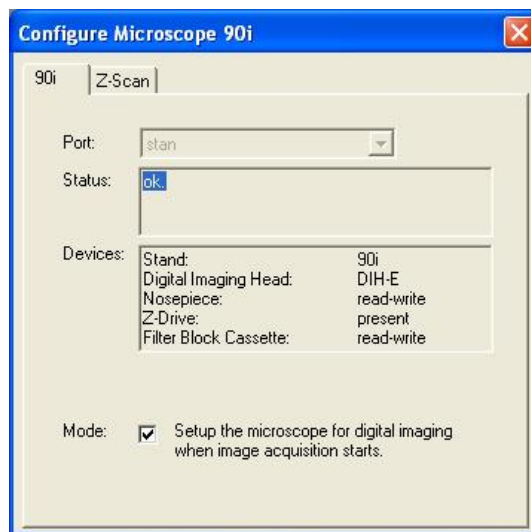
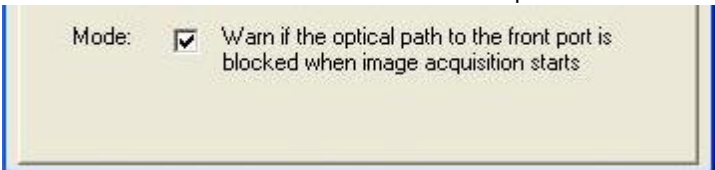

Figure 5.5-2 90i tab

The parameters are explained below:

Name	Function Overview
Port	USB port used to connect the 90i or 80i.
Status	Indicates “ok” when the 90i is operating normally.
Devices	Shows the connection status for the Nosepiece, Z-Drive, and ControlPad.
Mode	<p>Connection with 90i and DIH-E: If this check box is checked, when starting a scan, optical path, filter, diascope illumination lamp, analyzer, and shutter for the diascope illumination are set as the condition for confocal microscopes.</p> <p>Connection with 90i or 80i and DIH-M: If this check box is checked, when starting a scan, the condition of optical path, filter, diascope illumination lamp (only when used with 90i), and shutter for the diascope illumination are checked. And a warning message is displayed when these conditions are not set to Confocal microscopes.</p> 

5.5.2 Z-Scan tab

The Z-scan tab (Figure 5.5-3) is used to set the conditions of the Z-drive scanning. This tab contains the following controls:

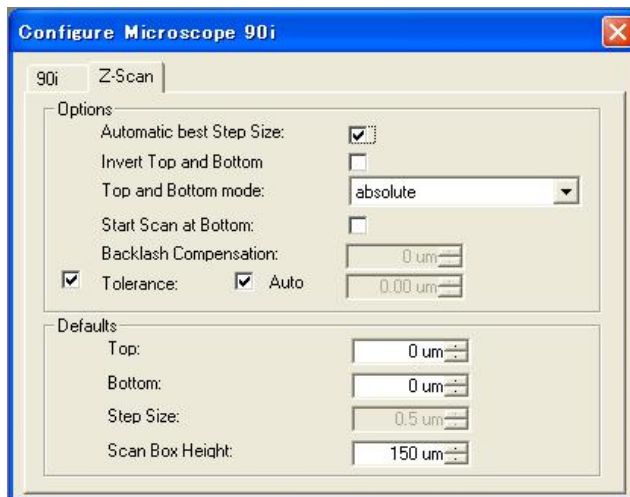

Figure 5.5-3 Z-Scan tab



Name	Function Overview
Options	
Automatic best Step Size	If this box is checked, the best step size is automatically calculated based on the resolution of the objective as specified under “Objective” on the “Configure” menu.
Invert Top and Bottom	Switches the direction of microscope movement relative to the stage from descending to ascending. Check this option if the direction of the movement of the microscope table and the position shown in the scan window are not the same.
Top and Bottom mode	This option is used to specify the format used when displaying the value for “Top” and “Bottom.” A relative distance from the reference is used if “relative to reference” is selected for the “Top” and “Bottom” values, whereas if “absolute” is selected, just as with the “reference,” an absolute distance from the position where the Z-drive started is used. There is no difference in operation.
Start Scan at Bottom	Check this option to start a 3D scan at the bottom instead of the top.

Backlash Compensation	<p>Use this function with automatic focusing control enabled to correct positioning errors resulting from backlashes caused by gear mechanisms. Enter a compensation value in the edit box in μm. The compensation value must be larger than any potential backlash value.</p> <ul style="list-style-type: none"> - The compensation value setting is available only with external units like the RFA drive unit or the E1000, whose mechanisms may result in backlash errors. - No compensation feature is provided for the 90i autofocusing unit, which has a control function that prevents backlash.
Tolerance	Specify the permissible deviation from the Z-position indicated on screen and the actual position observed by the microscope during 3D-image acquisition.
Auto	<p>Check this box to set automatically the tolerance to 1/7 of the optical resolution along the Z direction.</p> <p>Do not check this box to enter a value in the edit box in μm.</p>
Defaults	
Top	Specifies the default value for "Top." This option specifies a relative distance from the "Reference." Press the reset button to reset "Top" based on this value.
Bottom	Specifies the default value for "Bottom." This option specifies a relative distance from the "Reference." Press the reset button to reset "Bottom" based on this value.
Step Size	<p>Specifies the default step size value. The step size is set to this value when the EZ-C1 begins operation.</p> <ul style="list-style-type: none"> - If "Automatic best Step Size:" is checked, you can't change default step size because application set this parameter automatically.
Scan Box Height	This value specifies the maximum value allowable in the z-axis direction for the region displaying the scan range (the black square on the "Acquire Settings" window.) This is the maximum value which can be set for "Range."

5.5.3 Microscope Tools bar

When i Series Support Tools is installed, the Microscope Tools bar is displayed.

The Microscope Tools bar contains the following buttons:

Name	Function Overview
	The launcher button for i series; launches the i Control application.
	The launcher button for i series; launches the i Setup application.
 Confocal mode button	Optical path, Filter, Nosepiece, Diascopic Illumination Lamp, and Analyzer are set as the condition for confocal microscopes. (Only when it connects with "90i+DIH-E")

Connection with "90i+DIH-E":

Microscope Observation modes bar can be displayed from the Microscope Observation modes command of the Tools menu.

The Microscope Observation Modes bar contains the following buttons:



Figure 5.5-4 Microscope Observation Modes bar

Name	Function Overview
[BF] (Bright Field)	Microscopy for bright-field observation
[DIC] (DIC)	DIC observation
[DIC FL] (DIC/FL)	DIC and fluorescent simultaneous observation
[FL] (Fluorescence)	Fluorescent observation
[Ph] (Phase Contrast)	Phase contrast observation
[DF] (Dark Field)	Dark field observation
[1 to 6] (User Option)	Any observation method set by the user from i Control

Note

- You can set any desired observation method and name in User Options 1 to 6 using i Control. (For more information, refer to the i Series Support Tools Software Manual for the ECLIPSE-i series of microscopes.)

The table below lists the various possible operations for each motorized unit that operates in conjunction with the selected microscopy mode.

Table Standard Combinations of Microscopy Methods and Interlock

	90i				Universal condenser		Nosepiece	DIH-E					
	Diascopic lamp	ND filter	Field diaphragm	Z-axis	Turret	Aperture diaphragm	Switching	Filter cube	Field diaphragm	Shutter	Analyzer	Optical path switching	Zoom
Bright-field	ON	Interlocked w/ objective	Interlocked w/ objective	Interlocked w/ objective	BF/ 2-4x	Interlocked w/ objective	-	Address 6 or 8 (DIA) ^(Note)	-	CLOSE	OUT	-	-
DIC	ON	Interlocked w/ objective	Interlocked w/ objective	Interlocked w/ objective	DIC 1/2	Interlocked w/ objective	-	Address 6 or 8 (DIA) ^(Note)	-	CLOSE	IN	-	-
DIC/ epi-fl	ON	Interlocked w/ objective	Interlocked w/ objective	Interlocked w/ objective	DIC 1/2	Interlocked w/ objective	-	Address 1	Interlocked w/ zoom	OPEN	IN	-	-
Epi-fl	OFF	Interlocked w/ objective	-	Interlocked w/ objective	BF/ 2-4x	-	-	Address 1	Interlocked w/ zoom	OPEN	OUT	-	-
Phase contrast	ON	Interlocked w/ objective	Interlocked w/ objective	Interlocked w/ objective	Ph 1/2/3	Fully open	-	Address 6 or 8 (DIA) ^(Note)	-	CLOSE	OUT	-	-
Dark-field	ON	Interlocked w/ objective	Interlocked w/ objective	Interlocked w/ objective	DIC2/ 2-4x	Fully open	-	Address 6 or 8 (DIA) ^(Note)	-	CLOSE	OUT	-	-

"-" means not interlocked.



Fixed: Not user-changeable



Triggers the interlock

Interlocked w/ objective: Sets appropriate status according to the selected DIH optical path and the total magnification combining those of the objective and the zoom (interlocked with objective alone in the absence of the DIH).

Interlocked w/ zoom: Sets appropriate status according to the selected zoom status.

CAUTION

- Two types of turret are available for the DIH-E; six ports turret for six filter cubes and eight ports turret for eight filter cubes. The settings for the installed turret in the DIH-E are used for each microscopy.

5.6 Prior ProScan

EZ-C1 can be used to control Prior ProScan XY stages.

After a Prior ProScan is connected, select Devices in the Configure menu to display the Configure Devices dialog box. Select [Prior ProScan II without Z-Drive].

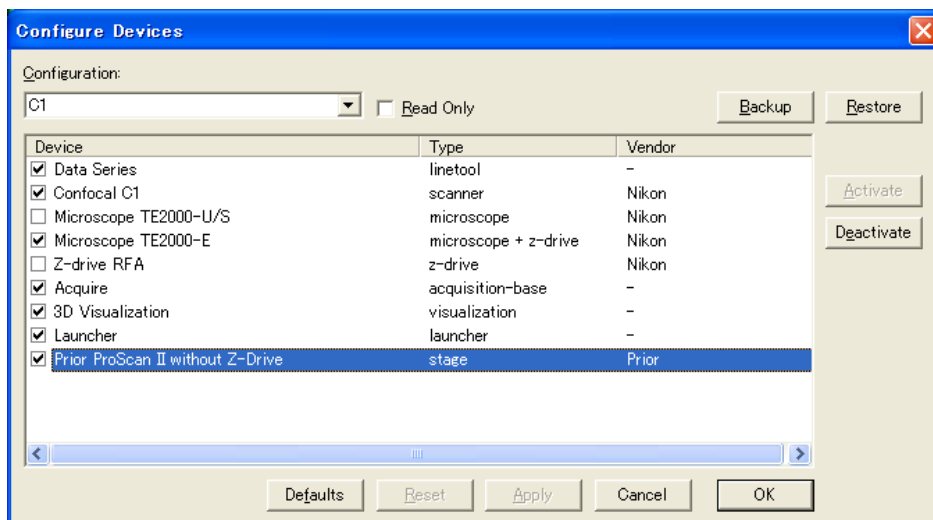

Figure 5.6-1 Configure Devices dialog box

After you have activated this device, a Prior ProScan command is added to the Configure menu and a Stage command is added to the Tools menu.

CAUTION

- The Prior ProScan driver must be installed before you can control the Prior ProScan from EZ-C1. Install the driver from the driver CD provided with Prior ProScan.

5.6.1 Controller tab

To display the Prior ProScan dialog box, select Prior ProScan in the Configure menu. The hardware connection status is indicated in the Controller tab.

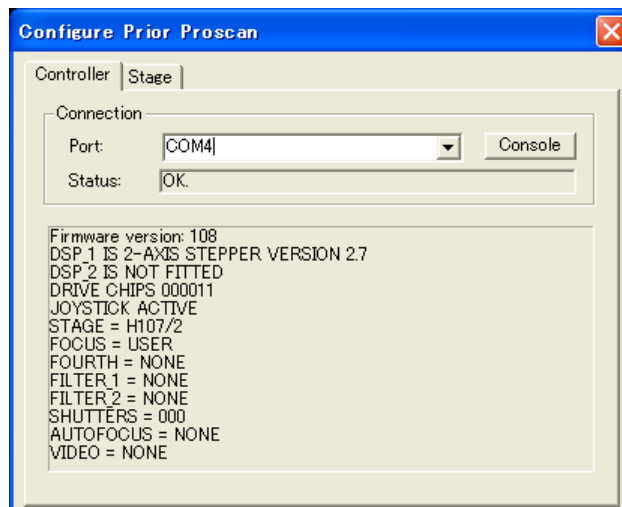



Name	Function Overview
Port	The COM port to which the Prior ProScan is connected.
[Console]	Displays the Console window. In this window, you can check the commands.
Status	OK indicates that the devices are working correctly.

5.6.2 Stage tab

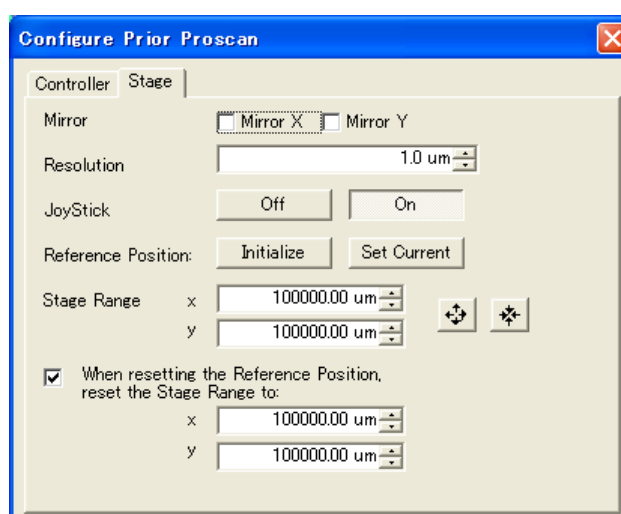
Use the Stage tab to configure various settings for XY stages. The parameters are defined as follows.





Name	Function Overview
Mirror	
Mirror X	Inverts the left and right coordinate information for stage movement.
Mirror Y	Inverts the forward and backward coordinate information for stage movement.
Resolution	Sets the level of resolution for stage movement. Specify the resolution in μm .
JoyStick	Activates or deactivates the joystick.
Reference Position	Sets the reference position for displaying the stage position. Initialize: Moves the stage to the reference position as set by the hardware and uses that position as the reference position. Set Current: Uses the current position as the reference position.

Stage Range	<p>Sets the range as displayed on the scroll bar of the Stage toolbar. (If the stage is moved beyond the range set here, the range displayed on the scroll bar of the Stage toolbar is automatically enlarged.)</p> <p>X: Stage range in the x direction Y: Stage range in the y direction</p> <p> : Increases the x and y value together.  : Decreases the x and y value together.</p>
When resting the Reference Position, reset the Stage Range to:	<p>When resetting the Reference Position, reset the Stage Range to: If you reset the reference position, the values for “Stage Range” are automatically reset to the values you specify here (only if the check box is selected).</p> <p>X: Stage range in the x direction when reset Y: Stage range in the y direction when reset</p>

5.6.3 Stage toolbar

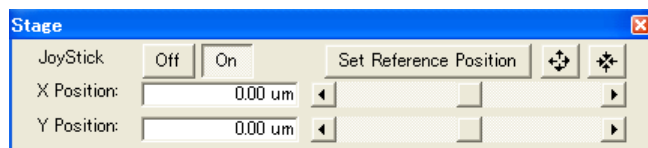
To display the Stage dialog box, select Stage in the Tools menu. EZ-C1 can be used to control the XY stage.



Name	Function Overview
JoyStick	Activates or deactivates the joystick.
[Set Reference Position]	Uses the current position as the reference position. The stage position is expressed relative to the reference position.
	Enlarges the range of movement in the scroll bars for the x and y positions.
	Reduces the range of movement in the scroll bars for the x and y positions.
X Position	Moves the stage in the x direction.
Y Position	Moves the stage in the y direction.

6

Visual Basic for Applications Support Functions

The EZ-C1 incorporates functions that support Visual Basic for Applications (hereafter abbreviated as VBA). In addition to the default menu items, you can assign macros (procedures) created with VBA to menus or to keystrokes.

6.1 VBA menu

The VBA menu available from the EZ-C1 main menu provides access to all VBA support functions.

Figure 6.1-1 shows the default (initial) status of the VBA menu.

The menu items located below “Keys” are custom user-defined menus which users can add to as desired (see 6.1.2).

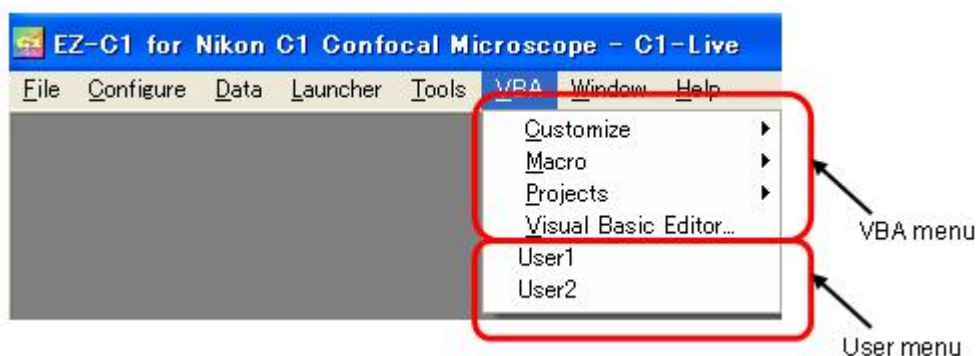

Figure 6.1-1 VBA menu

6.1.1 Customize menu

Select the Customize command from the VBA menu (see 6.1) to display the Customize menu (Figure 6.1-2).

The Customize command lets you register macros to a custom user menu or to a shortcut key.

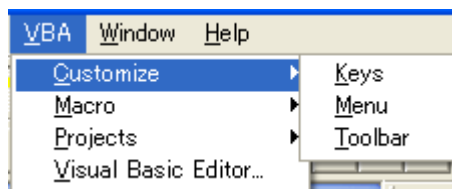

Figure 6.1-2 Customize menu

6.1.1.1 Keys

Select the Keys command from the Customize menu (see 6.1.1) to display the Keys tab on the VBA Options dialog box (Figure 6.1-3). Use this tab to assign macro functions to shortcut keys.

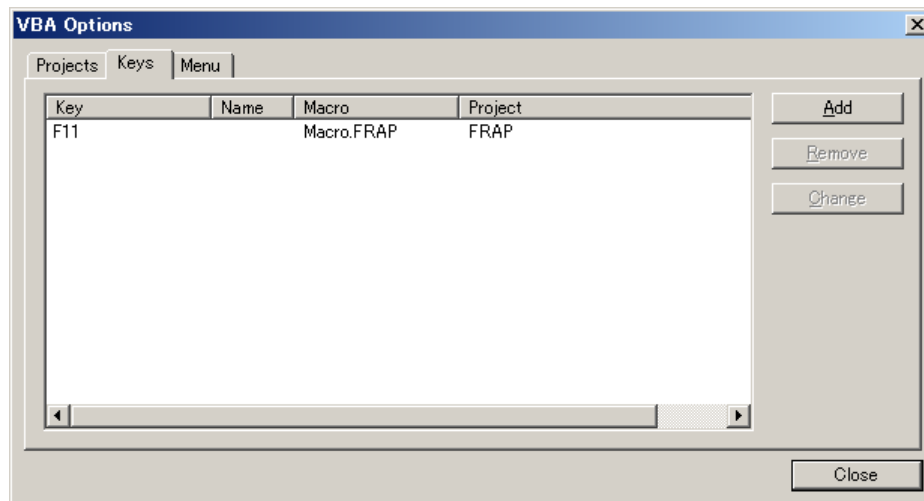

Figure 6.1-3 Keys tab on VBA Options dialog box

Name	Function Overview
Registration list	Lists registered shortcut keys. This list shows the keys and corresponding descriptions (see With Name in Figure 6.1-4) as well as macro projects and macros.
[Add]	Registers a new shortcut key. The command displays the Key Definition dialog box (Figure 6.1-4). * For more information, refer to Section, "Key Definition."
[Remove]	Deletes a registered shortcut key.
[Change]	Modifies the information of a registered shortcut key. Select a shortcut key to modify from the registration list, and then click this button. The command displays the Key Definition dialog box (Figure 6.1-4) and information on the selected shortcut key. * For more information, refer to Section, "Key Definition."
[Close]	Click this button to register all key assignments and close the dialog box.

Click the [Add] or [Change] button in the Key tab of VBA Options dialog box (Figure 6.1-3) to display the Key Definition dialog box (Figure 6.1-4). Use this dialog box to assign macro functions (procedures) to keys.

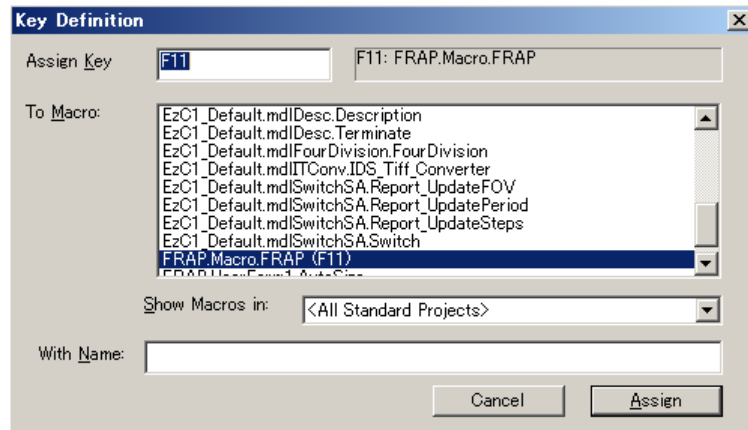

Figure 6.1-4 Key Definition dialog box

Name	Function Overview
Assign Key	Enter a shortcut key to which a macro is registered. (Type the desired key from the keyboard.) In the example in Figure 6.1-4, the shortcut key is the F11 key. If a command is already associated with the key entered here, the existing command association is displayed in the frame box next to the shortcut key.
To Macro	Select a macro command to be registered. In the example in Figure 6.1-4, "FRAP.Macro.FRAP" is the selected macro command.
Show Macros in	Select a project name in which a macro has been saved. You can also select all macro projects. In the example in Figure 6.1-4, all macro projects are selected.
With Name	Enter a description for the macro. In the example in Figure 6.1-4, this textbox is left blank.
[Cancel]	Discards the registration made and reverts to the previous state.
[Assign]	Executes the registration.

Note

- The following functions are assigned to the F1 and F12 keys in advance.
F1: Show EZ-C1 Help. (Works the same as selecting Help > EZ-C1 Help.)
F12: Hide all Tools dialog boxes and toolbars. (Works the same as selecting Tools > Hide All.)

6.1.1.2 Menu

Select the Menu command from the Customize menu (see 6.1.1) to go to the Menu tab on the VBA Options dialog box (Figure 6.1-5). Click this tab to assign macro functions to a custom user menu.

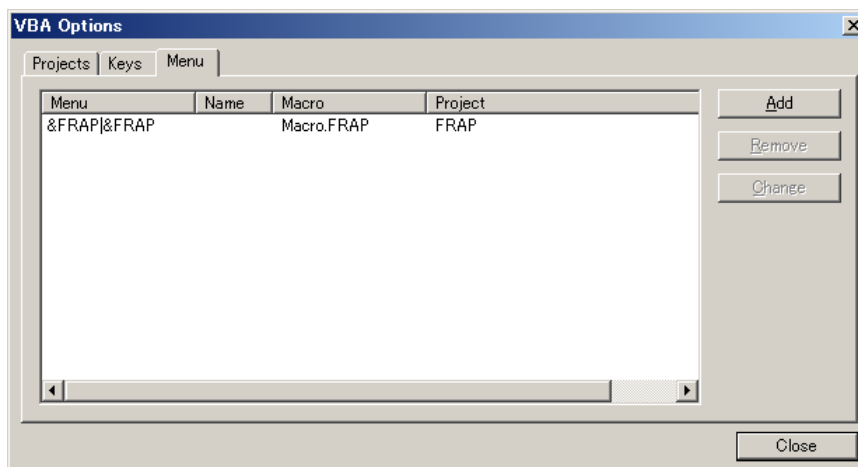

Figure 6.1-5 Menu tab on VBA Options dialog box

Name	Function Overview
Registration list	Lists all registered menus, along with descriptions (see With Name in Figure 6.1-6), as well as macro projects and macros.
[Add]	Registers a new menu. Displays the dialog box shown in Figure 6.1-6.
[Remove]	Deletes a registered menu.
[Change]	Modifies the contents of a registered menu. Select a menu you want to modify from the registration list and click this button. This displays the dialog box shown in Figure 6.1-6, which provides contents on the selected menu.
[Close]	Click to close the dialog box.

Click the [Add] or [Change] button in the Menu tab of VBA Options dialog box (Figure 6.1-5) to display the Key Definition dialog box (Figure 6.1-6). Use this dialog box to assign macro functions (procedures) to menus.

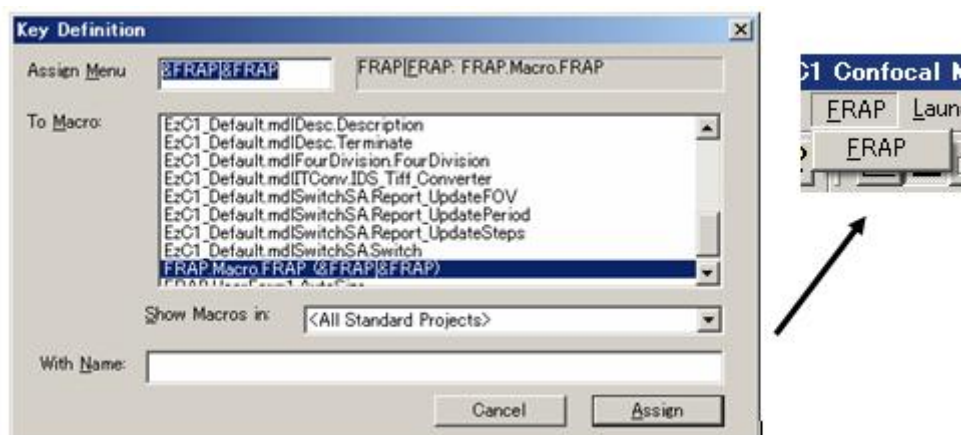

Figure 6.1-6 Key Definition dialog box (menu assignment and registered menus)

Name	Function Overview
Assign Menu	Enter the menu to be registered. The menu can be registered on the VBA menu bar or on the EZ-C1 menu bar. Enter a menu name in the format "name A" to register the menu as A on the VBA menu. If you enter "name A name B," a menu A with submenu B is registered on the EZ-C1 menu. (The " " creates a menu-submenu relationship.) In the example in Figure 6.1-6, a "FRAP" menu is registered in "FRAP." Add an "&" when entering a menu name to underscore the initial letter of the menu.
To Macro	Select a macro command to be registered. In the example in Figure 6.1-6, "FRAP.Macro.FRAP" is the selected macro command.
Show Macros in	Select a project name in which a macro has been saved. You can also select all macro projects. In the example in Figure 6.1-6, all macro projects are selected.
With Name	Enter a description for the macro. In the example in Figure 6.1-6, this textbox is left blank.
[Cancel]	Discards the registration made and reverts to the previous state.
[Assign]	Executes the registration.

6.1.1.3 ToolBar

Select the ToolBar command from the Customize menu (see 6.1.1) to display the ToolBar tab on the VBA Options dialog box (Figure 6.1-7). Use this tab to assign macro functions to tool buttons.

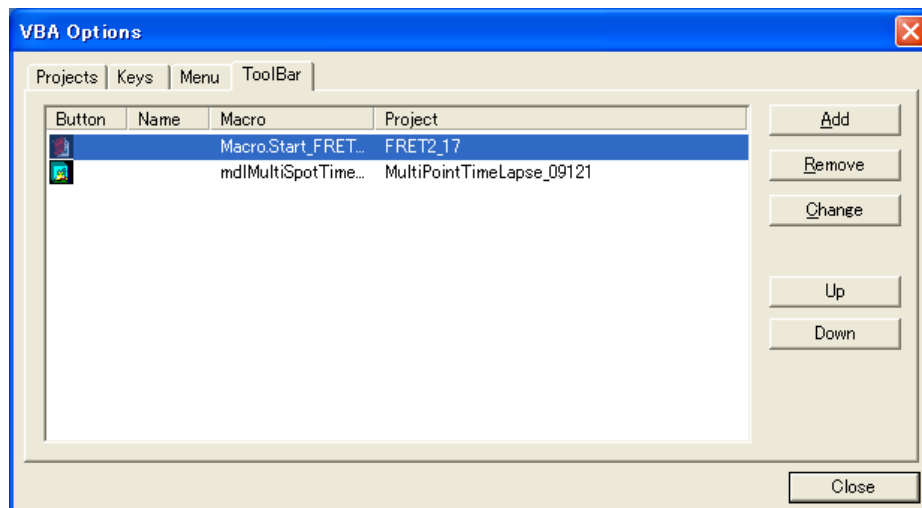

Figure 6.1-7 ToolBar tab of the VBA Options dialog box

Name	Function Overview
Registration list	List all registered tool buttons, along with descriptions (see With Name in Figure 6.1-8), as well as macro projects and macros.
[Add]	Registers a new tool button. Displays the dialog box in Figure 6.1-8.
[Remove]	Deletes a registered tool button.
[Change]	Modifies the contents of a registered tool button. Select a button you want to modify from the registration list and click this button. This displays the dialog box shown in Figure 6.1-8, which provides contents on the selected button.
[Up]	Move a selected button to be displayed in one line above.
[Down]	Move a selected button to be displayed in one line below.
[Close]	Click to close the dialog box.

Click the [Add] or [Change] button in the ToolBar tab of VBA Options dialog box (Figure 6.1-7) to display the Button Definition dialog box (Figure 6.1-8). Use this dialog box to assign macro functions (procedures) to tool buttons.

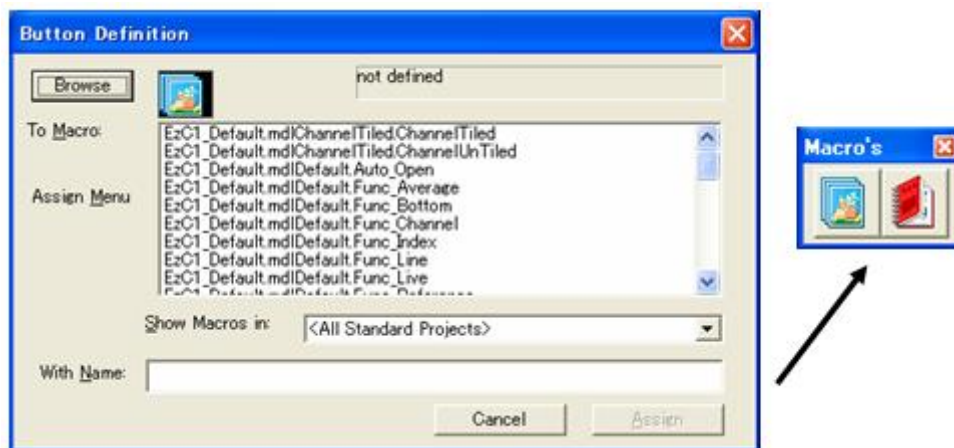

Figure 6.1-8 Button Definition dialog box (tool button assignment and assigned buttons)

Name	Function Overview
[Browse]	Select an icon file to be specified for a tool button. The image file specified here is displayed as a tool button in the “Macro’s” tool dialog box.
To Macro	Select a macro command to be registered. The macro function specified here starts by a corresponding tool button in the “Macro’s” tool dialog box.
Show Macros in	Select a project name in which a macro has been saved. You can also select all macro projects. In the example in Figure 6.1-8, all macro projects are selected.
With Name	Enter a description for the macro.

[Cancel]	Discards the registration made and reverts to the previous state.
[Assign]	Executes the registration.

6.1.2 Macro menu

Select the Macro command from the VBA menu (see 6.1) to display the Macro menu (Figure 6.1-9). The Macro command is used to create macros.

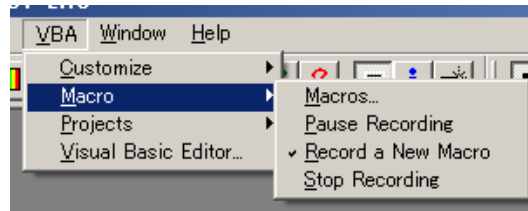

Figure 6.1-9 Macro menu

6.1.2.1 Macros

Select Macro command from the Macro menu (see 6.1.2) to display the Macros dialog box (Figure 6.1-10). Use this dialog box to run or edit a macro.

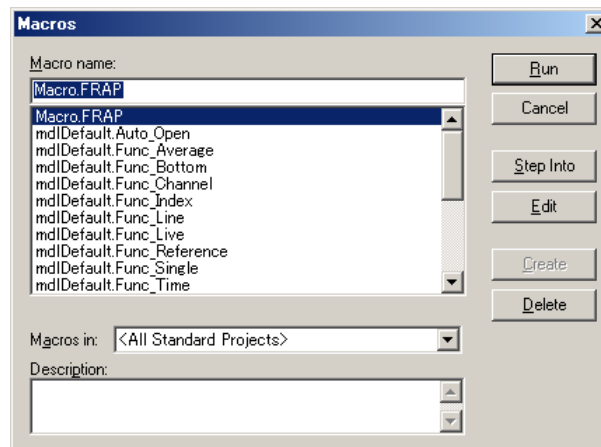

Figure 6.1-10 Macros dialog box

Name	Function Overview
Macro Name	Select a macro to run from the list of macros displayed here.
Macros in	Select a project name in which a macro has been saved. You can also select all macro projects. Figure 6.1-10 shows an example with all macro projects selected.
Description	Enter a description for the macro. In the example in Figure 6.1-10, this textbox is left blank.
[Run]	Executes the selected macro.
[Cancel]	Closes the dialog box.

[Step Into]	Invokes debug mode. The selected macro is executed line by line.
[Edit]	Edits macros. The macro selected is displayed followed by the Visual Basic Editor (see 6.1.4).
[Create]	Creates a new macro. When creating a new macro, enter a name for the new macro in Macro Name.
[Delete]	Deletes the selected macro.

6.1.2.2 Pause Recording

Use the Pause Recording command from the Macro menu (see 6.1.2) to temporarily suspend the Record a New Macro (see 6.1.2.3).

6.1.2.3 Record a New Macro

Select Record a New Macro from the Macro menu (see 6.1.2) to display the Record a new Macro dialog box (Figure 6.1-11). Enter a name for the new macro, then begin recording the macro.

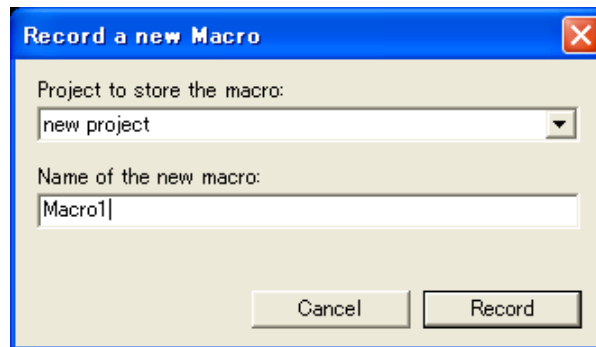

Figure 6.1-11 Record a new Macro dialog box

Name	Function Overview
Project to store the macro	Enter a name of the project name in which you want to save the macro.
Name of the new macro	Enter the name of the new macro.

Click [Record] after entering a name in this dialog box. Subsequent operations performed via the GUI interface are recorded as a new macro.

Select Pause Recording (see 6.1.2.2) to suspend macro recording if you want to exclude some operation from the recorded macro.

To finish recording the macro, choose Stop Recording (see 6.1.2.4).

You can now perform the entire sequence of operations recorded as part of the macro simply by running the recorded macro (by selecting the Macro command: see 6.1.2.1).

6.1.2.4 Stop Recording

Select Stop Recording from the Macro menu (see 6.1.2) to end macro recording.

6.1.3 Projects menu

Select the Projects command from the VBA menu (see 6.1) to display the Projects menu (Figure 6.1-12). Use the Projects command to create, edit, load, or save a macro project.

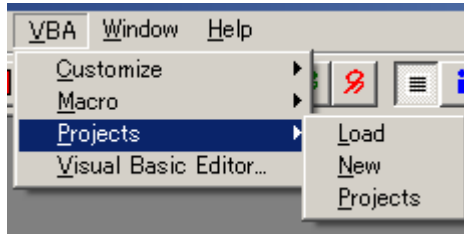

Figure 6.1-12 Projects menu

6.1.3.1 Load

Select the Load command from the Projects menu (see 6.1.3) to load a macro project. Macro project files are identified by the “.ezm” extension.

6.1.3.2 New

Select the New command from the Projects menu (see 6.1.3) to create a new macro project. Creating a new macro project generates a temporary project file.

6.1.3.3 Projects

Use the Projects command from the Projects menu (see 6.1.3) to go to the Project tab on the VBA Options dialog box (Figure 6.1-13). Click this tab to create, edit, load, or save a macro project.

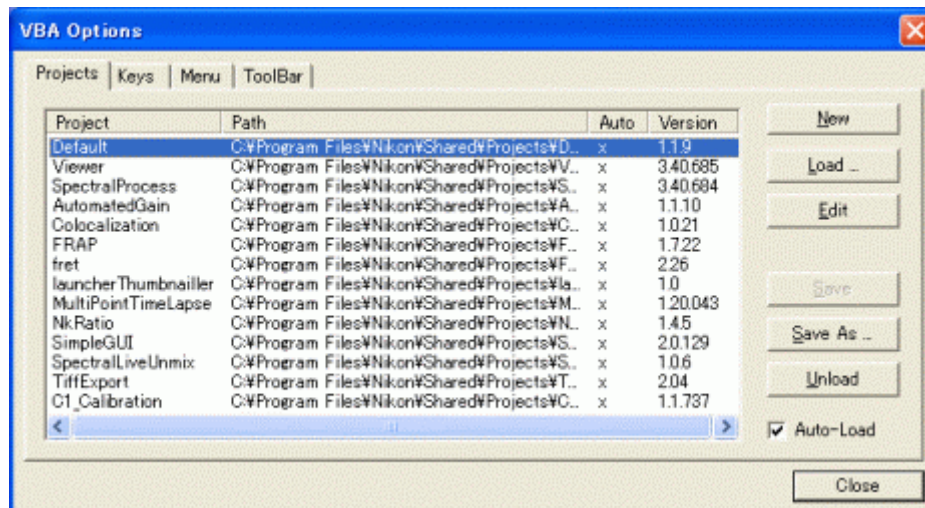

Figure 6.1-13 Project tab on VBA Options dialog box

Name	Function Overview
Project list	Lists the macro projects loaded by EZ-C1. The information displayed consists of “Project” (project name), “Path” (to project file), “Auto” (whether to load the file automatically the next time EZ-C1 starts), and “Version” (of macro file). Projects set for automatic loading are marked by an X in the “Auto” column.

[New]	Creates a new macro project. Equivalent to the New command on the Macro menu (see 6.1.3.2).
[Load]	Loads a macro project file. Equivalent to the Load command on the Macro menu (see 6.1.3.1).
[Edit]	Edits a macro. Equivalent to function available from the Visual Basic Editor menu (see 6.1.4).
[Save]	This button is enabled if changes have been made to a macro project. The modified macro project overwrites the previous version.
[Save As]	This button is enabled if changes have been made to a macro project. The modified macro project is saved under a new name.
[Unload]	Disables loading by EZ-C1 for selected macro project files. Note that the files selected here will not be loaded the next time the EZ-C1 starts, even if Auto Load is enabled.
Auto-Load	Sets macro project files selected from the list for automatic loading at subsequent startups.
[Close]	Closes the dialog box.

6.1.4 Visual Basic Editor

Select Visual Basic Editor command from the VBA menu (see 6.1) to display the Visual Basic Editor dialog box (Figure 6.1-14).

* For more information, refer to the Help files for the VBA development environment.

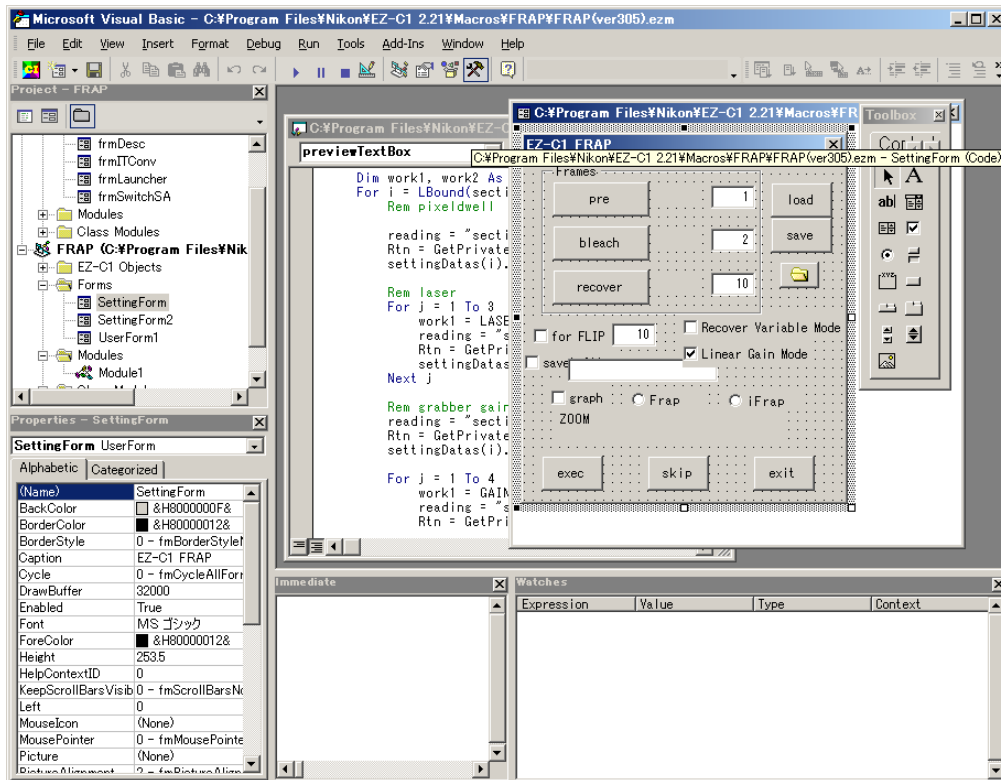





Figure 6.1-14 VBA development environment (Visual Basic Editor dialog box)



6.1.5 Projects bar

The Projects bar contains shortcut buttons for access to functions available from the VBA menu. The Projects bar is one of the tool dialog boxes (see 4.8) that can be displayed by choosing Projects Bar from the EZ-C1 Tools menu.



The Projects bar includes the following buttons.

Name	Function Overview
	Lets you create, edit, load, or save a macro project (see 6.1.3.3).
	Loads a macro project (see 6.1.3.1).
	Displays Visual Basic Editor (see 6.1.4).
	Executes a selected macro (see 6.1.2.1).

	Begins macro recording (see 6.1.2.3).
	Ends macro recording (see 6.1.2.4).
	Pauses macro recording (see 6.1.2.2).

6.2 Description of Macro-related Files

6.2.1 Default project

The default project is a macro file that is automatically read each time EZ-C1 starts up.

Named "Default.ezm," this file is located in the same directory as EZC1.EXE.

The default project also automatically runs a procedure named "Auto_Open" in the Default.ezm standard module.

The default project cannot be edited directly. To edit it, copy it to another directory, then open it as a user project using the "Open Macro File" menu command.

The following three macro types are provided for the default project.

Switch Scanning Area procedure (see 4.5.3)

This default project applies several scanning settings simultaneously.

IdsTiffConvert (see 4.5.2)

This default project converts ids files into tiff files continuously.

Channel Tiled / Untiled (see 4.5.1)

This default project reproduces three windows based on the selected window.

6.2.2 User project

A user project is a VBA project that records macros created by users using EZ-C1.

Usually, a user project is edited by the user. A user project is also created when macro recording is executed.

The file or directory can be named by the user when a project is saved.

6.2.3 Settings files

The following settings files have been added for VBA compatibility.

6.2.3.1 Macro definition file

File name EZMACRO.TBL

Folder Folder in which EZ-C1 is installed

This is a key name definition file that can be used by the Run method. It matches the name of the window path used by the "Configure Keys" function to the name of the key used by the VBA function.

#comment	Comments are preceded by a "#."
KEY:[Open]	Name of key used by Run method
VALUE:[Command.Open]	Name of window path used by Configure Key

6.2.3.2 VBA project settings file

File name EZMACRO.INI
Folder Folder in which EZ-C1 is installed

This file contains information registered in the menu, as well as the file name of the user project to be opened on subsequent startup.

[VBA]

NextOpenMacro=C:\Macros\user.ezm User project to be opened on subsequent startup

[Customize]

Item registered in menu

Procedures=3

Number of items registered in menu

Procedure1=MenuName1;Module1.Menu1 Contents of Menu 1

Procedure2=MenuName2;Module1.Menu2 Contents of Menu 2

Procedure3=MenuName3;Module1.Menu3 Contents of Menu 3

6.2.4 Method

Refer to “EZ-C1 Macro Reference.”

A

Experiment Sequence Macro

Each macro file is provided on the CD-ROM disc. These macro files are installed together with the EZ-C1 application software if the application software is installed using the EZ-C1's integrated installer (All EZ-C1 3.80 Project). The file is installed in a folder named Program Files\Nikon\Shared\Projects.

Use the following procedure to load these macro files:

- When macros are installed at the first start-up of the EZ-C1 immediately after installation, a dialog box prompting for Auto Load settings confirmation appears. The macros set to load here are automatically loaded at the following start-up.

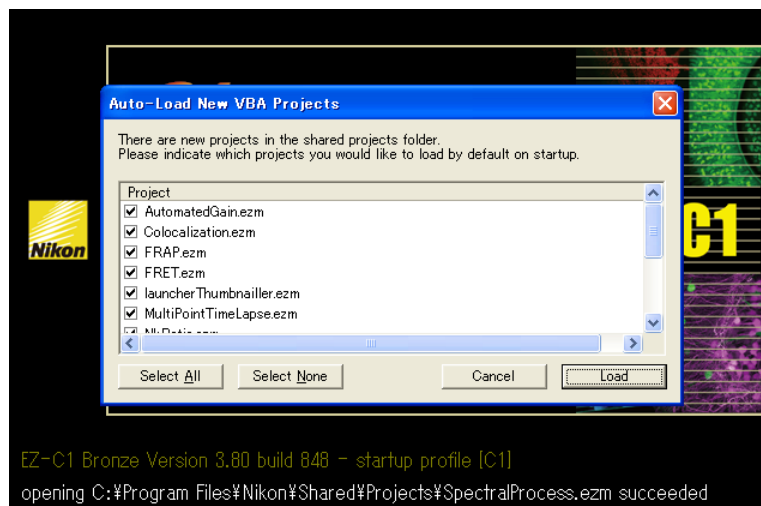

- If macros that are not set to Auto Load are installed at the second and the following start-up, Auto Load setting is performed for each macro or a confirmation dialog box is displayed. The macros that are set here to Auto Load are automatically loaded at the following start-up.

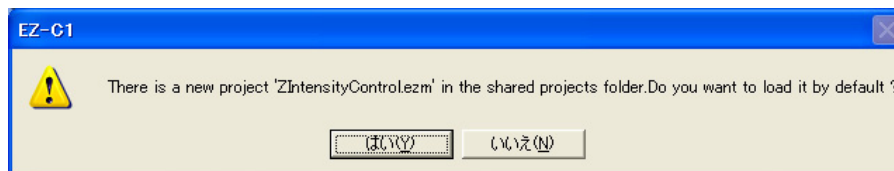

- To set macros that are not automatically set to Auto Load while the EZ-C1 is starting, perform the following procedure (example: Frap macro).

Select “Projects” in the “VBA” menu. And then, select “Projects” in the list.

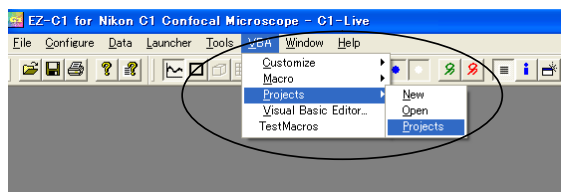

The “VBA Options” dialog box appears. Press the [Load] button in the box.

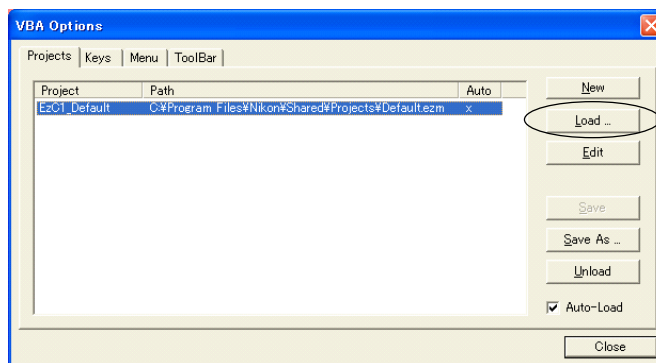

Select the FRAP macro file, FRAP.ezm.

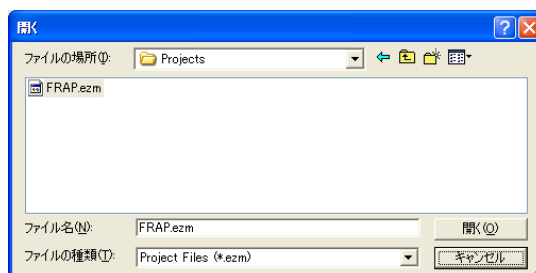

Specify the setting to read the FRAP macro file.

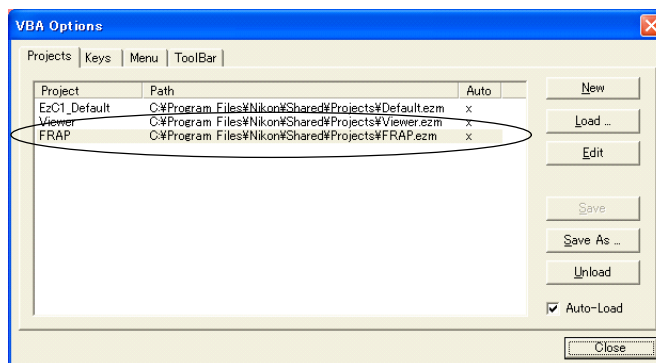

Select the FRAP macro file. Check the “Auto-Load” check box.

Once the “Auto-Load” checkbox is selected, when the EZ-C1 is exited and then restarted, the FRAP macro file will be read automatically.

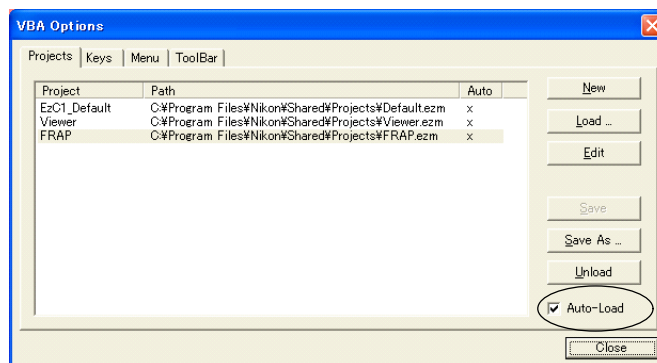

The “FRAP” menu appears in the EZ-C1 menu automatically.



Note

- | | |
|---|-----------------------------------|
| - FRAP/FLIP Sequence Macro: | FRAP.ezm |
| - 2 Excitation 1 Emission Ratio Sequence Macro: | Nk Ratio.ezm |
| - Multipoint Time-lapse Macro: | MultiPoint TimeLapse.ezm |
| - FRET Sequence Macro: | FRET.ezm |
| - Colocalization Macro: | Colocalization.ezm |
| - Auto Gain Macro: | AutomatedGain.ezm |
| - Live Unmix Macro: | SpectralLiveUnmix.ezm |
| - Z-stack Intensity Control Macro: | ZIntensityControl.ezm |
| - Tiff Series Export Macro: | TiffExport.ezm |
| - SimpleGUI Macro: | SimpleGUI.ezm, SimpleGUISetup.ezm |
| - Thumbnailer: | launcherThumbnailer.ezm |

A.1 FRAP Sequence Macro

To perform the fluorescence recovery after photobleaching (FRAP), carry out the following. (Refer to 5.2.1, and specify the laser, AOM, and AOTF beforehand)

1 Check the settings of the laser, AOM, and AOTF

[For the three-laser unit]

Check the laser and AOM settings.

Select the “Confocal C1” in the “Configure” menu to show the “Configure Confocal C1” dialog box.

Select the “Lasers” tab and press the [setup] button of the laser to be bleached.

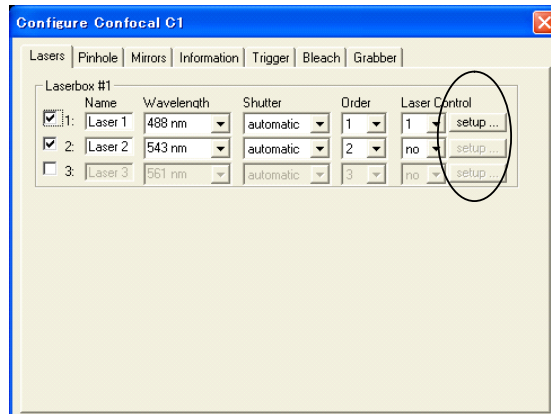

Check the following terms in the “Laser Intensity Control Setup” dialog box: The “Brand” of the “Device Type” is “Nikon AOM.” The “Laser Power” of the “Calibration” is “100%.” The “Type” is “calibration table.” And the “Table” is “Nikon AOM XXX.cal.” (Here, “XXX” must be the same number as the wavelength of the laser.)
 When a 405 (408) laser diode is installed on the system, items must be set as follows: The “Brand” of the “Device Type” is “Melles & Griot.” The “Laser Power” of the “Calibration” is “100%.” The “Type” is “calibration table.” And the “Table” is “Melles & Griot XXX.cal.” (Here, “XXX” must be the same number as the wavelength of the laser.)

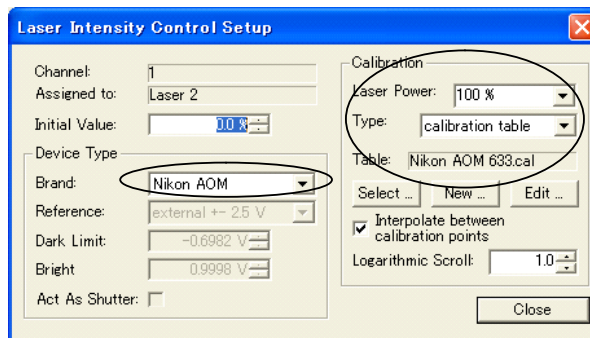

[For the four- laser unit]

Check the laser and AOTF settings.
 Select the “Confocal C1” in the “Configure” menu to show the “Configure Confocal C1” dialog box.
 Select the “Lasers” tab and press the [setup] button of the laser to be bleached.

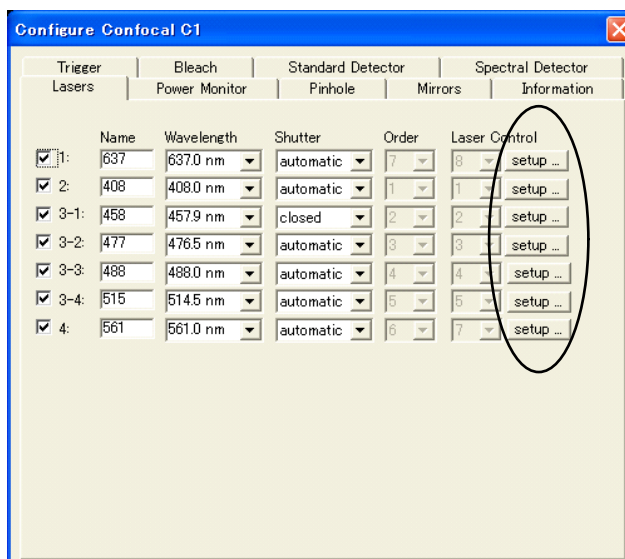

Check the following terms in the “Laser Intensity Control Setup” dialog box: The “Brand” of the “Device Type” is “Nikon AOTF.” The “Laser Power” of the “Calibration” is “100%.” The “Type” is “calibration table.” And the “Table” is “Nikon AOTF XXX.cal.” (Here, “XXX” must be the same number as the wavelength of the laser.) When a 405 (408), 440, or 640 (647) nm laser is installed on the system, items must be set as follows: The “Brand” of the “Device Type” is “Melles & GriotXXX.” The “Laser Power” of the “Calibration” is “100%.” The “Type” is “calibration table.” And the “Table” is “Melles & Griot XXX.cal.” (Here, “XXX” must be the same number as the wavelength of the laser.)

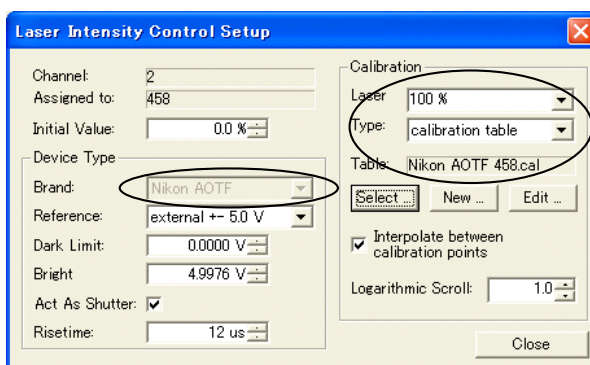

CAUTION

- Do not change any other items except above.
- For the four-laser unit, the “Brand” option cannot be changed.

The laser to be used for bleaching must be selected as follows:

Select the "Laser Control Bar" of the "Tools" menu to show the "Laser Control Bar" dialog box. Select the [In Spots] button. And then, select the check box of the laser to be used for bleaching.

[For the three-laser unit]

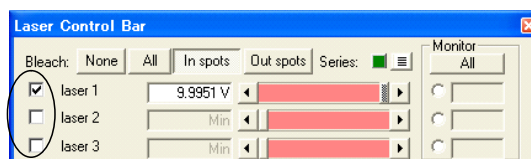

[For the four-laser unit]

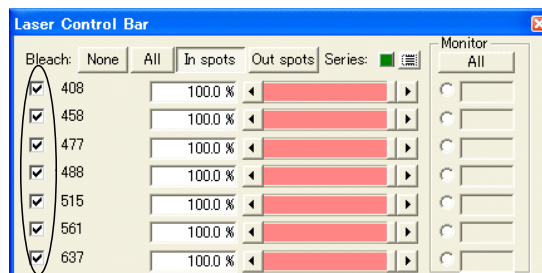

2 Load the FRAP Sequence macro

Note

- The FRAP sequence macro file is provided on the CD-ROM disc. This macro is installed together with the EZ-C1 application software if the application software is installed using the EZ-C1's integrated installer (All EZ-C1 3.80 Project).

The file is installed in a folder named "Program Files\Nikon\Shared\Projects."

For loading the macro file, refer to the head description of "A Experiment Sequence Macro."

3 Set a spot

Scan an image and create a spot on the image.

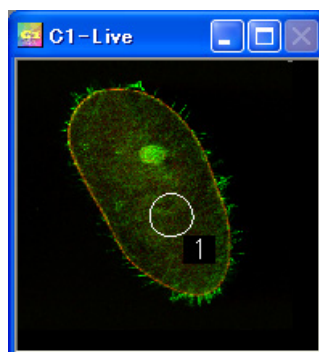

4 Specify the setting of bleaching on/off for the spot

Specify the setting of bleaching on/off for each spot by using the “Spots Of Interest” tab of the “View Settings” window. (See 4.3.6.)

The “Laser Power” value becomes “0%” regardless of settings for area other than bleached.

To carry out an experiment of iFrap, refer to the example below and define an area in a cell that will not be bleached.

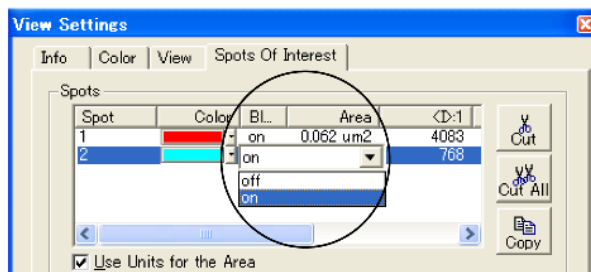

Example of bleaching:

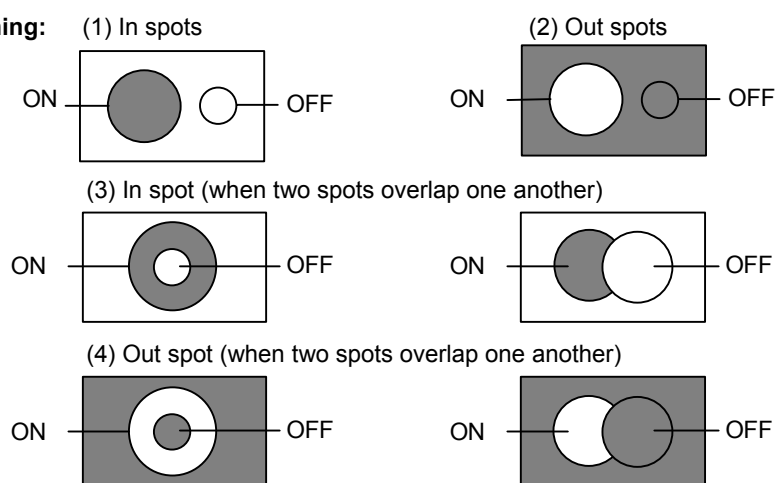

5 Run the FRAP application software

Select “FRAP” in the “FRAP” menu.



CAUTION

- The FRAP sequence macro can be used in the standard mode and the spectrum mode. But, the FRAP sequence macro does not detect the mode change between the standard mode and the spectrum mode when running. Therefore, if the mode is changed, the macro issues a warning message and is aborted. To restore the system, select the menu and start the macro again.
- Do not run another macro when the FRAP sequence macro is running.

6 Select the PMT gain operation mode

Specify the PMT gain operation mode as “Linear Gain Mode” or not.

Usually, select the same mode as the PMT operation mode of the EZ-C1.

When the check box of “Show this dialog again” is checked, the macro runs with the PMT gain operation mode set above.

To display the dialog box again, delete the file below.

Program Files\Nikon\Shared\Projects\lineargain.ini

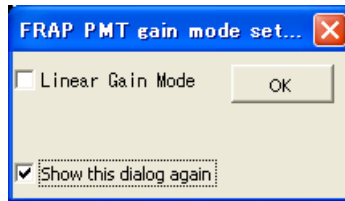

CAUTION

- The file, Program Files\Nikon\Shared\Projects\lineargain.ini, is used in the following three macros in common: the FRAP sequence macro, FLIP sequence macro, sequence macro for specimen excited with lights of two wavelengths but emitting a fluorescent light of one wavelength. Therefore, the “Show this dialog again” setting will be reflected to other sequence macros.

7 Display the FRAP application dialog box

The FRAP application dialog box appears.

In this window, specify the frame count for each phase of “Preview”, “Bleach”, and “Recover.”

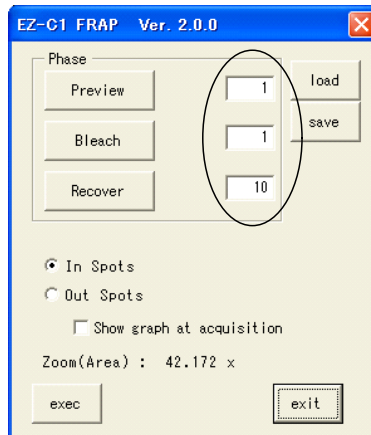

Note

- **[Preview]:** This is a phase to be performed before bleaching. Normally specify one frame.
- **[Bleach]:** This is a phase of bleaching. Normally specify one frame.
- **[Recover]:** This is a phase after bleaching to observe the recovering specimen. Normally specify several frames.

8 Specify the “Preview” phase settings

Specify the “Preview” phase settings as follows:

A “Preview” phase starts when the [Preview] button on the FRAP application dialog box is pressed. The “preview setting” dialog box appears. The default settings are the same as the settings of EZ-C1. To change the settings, perform the followings: Press the [Live] button to show a live image. Check the image and specify each setting of “pixel dwell”, “laser”, and “gain.”

To capture several frames, specify the “Time series” option in the “interval (frame) time setting. (But, the “Variable Delay Mode” option cannot be used.)

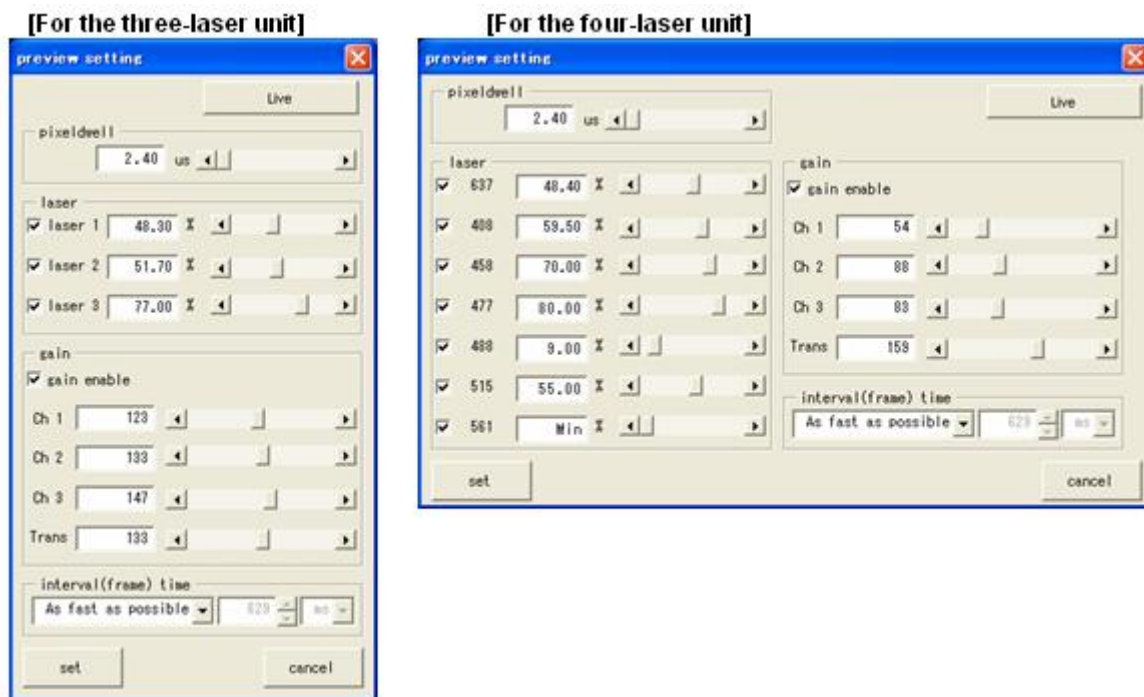

Note

- **Live:** Press this button to start a live image display.
- **pixel dwell:** Specify the exposure time of the laser for each pixel.
- **laser checkbox:** Set the laser to be used in the “Preview” phase. This option is used when the laser wavelength used in the “Bleach” phase differs from the laser wavelength used in the “Preview” phase.
- **laser:** Set the laser power used in the “Preview” phase to the right of the laser check box.
- **gain:** Set the PMT gain used in the “Preview” phase.
- **gain enable:** Check this check box to enable the PMT gain setting. Normally, this option is enabled in the “Preview” phase.
- **interval time:** Select the “As fast as possible” option or the “With fixed delay” option. When the “With fixed delay” option is used, the time interval must be set with [ms] (milliseconds), [s] (seconds), or [m] (minutes).

[Default settings of the “Preview” phase]

- **pixel dwell:** Set values in EZ-C1 are copied here.
- **laser checkbox:** All lasers are ON.
- **laser:** Set values in EZ-C1 are copied here.
- **gain:** Set values in EZ-C1 are copied here.
- **gain enable:** Enabled
- **interval time:** “As fast as possible”

If the specimen has been checked with EZ-C1 and the image has no problem, the settings for the “Preview” phase does not need any change.

9 Specify the “Bleach” phase settings

Specify the “Bleach” phase settings as follows:

A “Bleach” phase starts when the [Bleach] button on the FRAP application dialog box is pressed. The “bleach setting” dialog box appears. Specify the “laser” and “gain” settings for the “Bleach” phase. The default settings are the followings: The “pixel dwell” value is the same as the “Preview” setting. All laser powers are “100%.” All gains are 0.

A “Scan zoom area selection [selected]” window also appears. Scan areas to be bleached are defined on this window. To define a scan area, create a rectangle with mouse operation. If no area is defined here, an area will be defined automatically where all spots are included.

[For the three-laser unit]



[Define bleach areas]

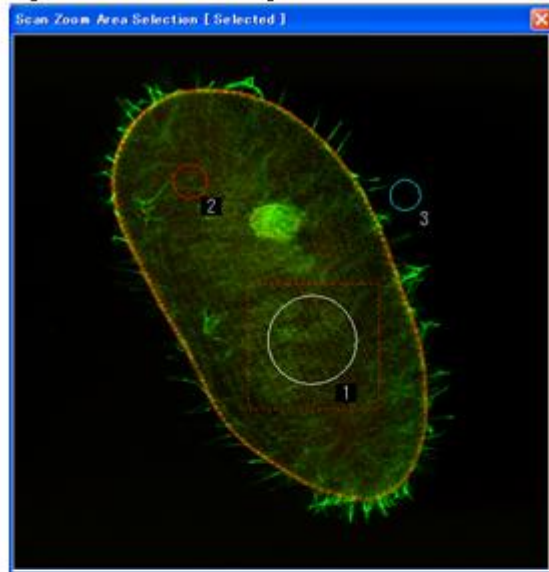

[For the four-laser unit]

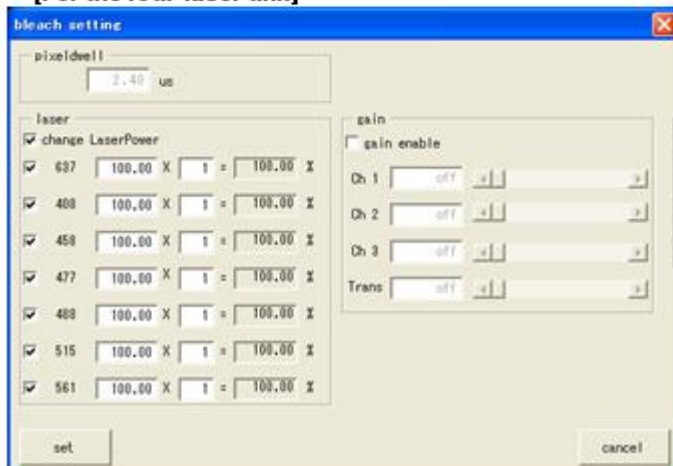

Note

- **pixel dwell:** The exposure time of the laser for each pixel is shown here. (It is the same value as the “Previous” setting.)
This value cannot be changed here. To change this value, use the “Preview Setting” dialog box.
- **laser checkbox:** Set the laser to be used in the “Bleach” phase.
This option is used when the laser wavelength used in the “Bleach” phase differs from the laser wavelength used in the “Preview” phase.
- **laser:** Set the laser power used in the “Bleach” phase to the right of the laser check box. Normally, this is “100%.”
To specify another laser power, select the [change Laser Power] option.
- **change Laser Power:** This check box is checked to change the laser power used in the “Bleach” phase from “100%.”
- **gain:** Set the PMT gain used in the “Bleach” phase. Normally, this is “0.”
To specify another gain, select the [gain enable] option.
- **gain enable:** This check box is checked to change the gain used in the “Bleach” phase from “0.”

To show the image in the “Bleach” phase, the following items must be set. Check the “gain enable” option. Change the menu to the “Configure” menu. Select the “Confocal C1” to show the “Configure Confocal C1” dialog box. Select the “Bleach” tab. Unselect the “Block Detectors during Bleaching” option. But if the amount of input light is too large, EZ-C1 automatically shuts down the voltage supply for the PMT gain. To disable the automatic shut down, the “Block Detectors during Bleaching” is normally checked. When the checkbox is checked, the gain is set as “0” and the image does not appear during bleaching.

[Default settings of the “Bleach” phase]

- **pixel dwell:** Set values for the “Preview” phase are copied here.
- **laser checkbox:** Selected lasers in step 1 “Check the settings of the laser, AOM, and AOTF” for bleaching are set as ON.
- **laser:** This entry is set as “100%.”
- **change Laser Power:** This check box is not checked.
- **gain:** This entry is set as “0.”
- **gain enable:** Disabled
- **Scan area:** The scan area is set as a rectangle that circumscribes all spot areas.

You don’t need any change when the default settings are effective.

10 Specify the “Recover” phase settings

Specify the “Recover” phase settings as follows:

A “Recover” phase starts when the [Recover] button on the FRAP application dialog box is pressed. The “recover setting” dialog box appears. Specify the “laser” and “gain” settings for the “Recover” phase. The default settings are same as that of the “Preview” phase.

To capture several frames in the “Recover” phase, specify the “Time series” option in the “interval (frame) time” setting. (But, the “Variable Delay Mode” option cannot be used.)

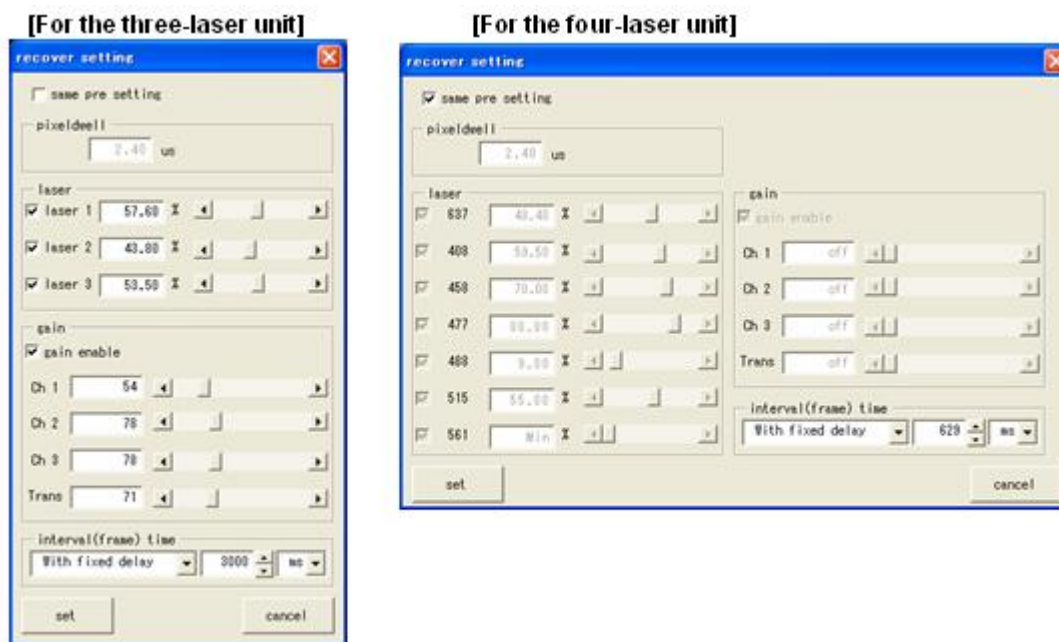

Note

- **same pre setting:** This check box is used to specify the “laser” and “gain” settings for the “Recover” phase as the same settings of the “Preview” phase. To specify the settings independently, do not check this check box. To specify the settings same as the “Preview” phase, check this check box. Normally, check it.
But, the “pixel dwell” and “interval (frame) time” settings are not effected by this check box.
- **pixel dwell:** The exposure time of the laser for each pixel is shown here. (It is the same value as the “Previous” setting.)
This value cannot be changed here. To change this value, use the “Preview Setting” dialog box.
- **laser checkbox:** Set the laser to be used in the “Recover” phase. This option is used when the laser wavelength used in the “Recover” phase differs from the laser wavelength used in the “Preview” phase or “Bleach” phase. To use this option, the “same pre setting” check box must be off.
- **laser:** Set the laser power used in the “Recover” phase to the right of the laser check box. To use this option, the “same pre setting” check box must be off.
- **gain:** Specify the PMT gain used in the “Recover” phase. To use this option, the “same pre setting” check box must be off.
- **gain enable:** Check this check box to enable the PMT gain setting. To use this option, the “same pre setting” check box must be off.
- **interval (frame) time:** Select the “As fast as possible” option or the “With fixed delay” option. When the “With fixed delay” option is used, the time interval must be set with [ms] (milliseconds), [s] (seconds), or [m] (minutes).
This option is normally used in the “Recover” phase.

[Default settings of the “Recover” phase]

- **same pre setting:** This check box is on. Normally, the setting for the “Recover” phase is set the same as the “Preview” phase.
- **pixel dwell:** Set values for the “Preview” phase are copied here.
- **laser checkbox:** Set values for the “Preview” phase are copied here.
- **laser:** Set values for the “Preview” phase are copied here.
- **gain:** Set values for the “Preview” phase are copied here.
- **gain enable:** Set values for the “Preview” phase are copied here.
- **interval time:** “As fast as possible”

Normally, the settings of the “Recover” phase are the same as that of the “Preview” phase. Therefore, the default settings are effective. But in some cases, the “interval (frame) time” setting is changed from the default setting. The “Recover phase setting” dialog box is used for such cases.

You do not need to change settings for the “Recover” phase, if there is no problem with the option “As fast as possible” selected for “interval (frame) time” and the other default settings the same as the “Preview” phase.

11 Execute the FRAP sequence

After specifying settings for the “Preview”, “Bleach”, and Recover phase, press the [exec] button on the FRAP application software window to start a FRAP sequence. The FRAP sequence processes each phase, captures images, and displays images and data in graphical form.

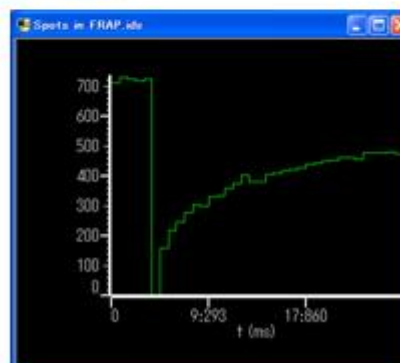
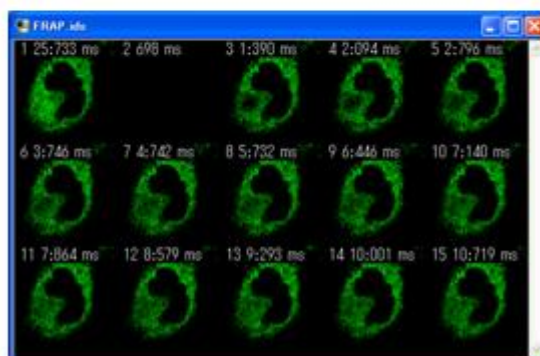
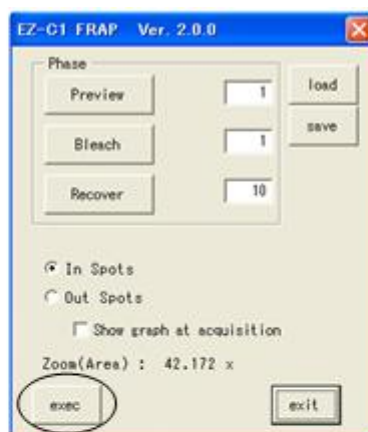

Note

When you use default settings for each phase, you can omit setting each phase. If you observe the specimen with EZ-C1, the settings of EZ-C1 will be copied to the settings of the "Preview" and "Recover" phases. And for the settings of the "Bleach" phase, the laser power will be set as "100%." To perform a time-lapse photographing with the "As fast as possible" setting in a FRAP experiment, specify the image count on the FRAP application window and simply press the [exec] button.

Default settings for each phase are described as follows:

[Default settings of the "Preview" phase]

- **pixel dwell**: Set values in EZ-C1 are copied here.
- **laser checkbox**: All lasers are ON.
- **laser**: Set values in EZ-C1 are copied here.
- **gain**: Set values in EZ-C1 are copied here.
- **gain enable**: Enabled
- **interval (frame) time**: "As fast as possible"

[Default settings of the "Bleach" phase]

- **pixel dwell**: Set values for the "Preview" phase are copied here.
- **laser checkbox**: Selected lasers in step 1 "Check the settings of the laser, AOM, and AOTF" for bleaching are set as ON.
- **laser**: This entry is set as "100%."
- **change Laser Power**: This check box is not checked.
- **gain**: This entry is set as "0."
- **gain enable**: Disabled
- **Scan area**: The scan area is set as a rectangle that circumscribes all spot areas.

[Default settings of the "Recover" phase]

- **same pre setting**: This check box is on. Normally, the setting for the "Recover" phase is set the same as the "Preview" phase.
- **pixel dwell**: Set values for the "Preview" phase are copied here.
- **laser checkbox**: Set values for the "Preview" phase are copied here.
- **laser**: Set values for the "Preview" phase are copied here.
- **gain**: Set values for the "Preview" phase are copied here.
- **gain enable**: Set values for the "Preview" phase are copied here.
- **interval (frame) time**: "As fast as possible"

12 Other functions

The FRAP application software also has following functions.

[save] [load]: These functions save/load the settings of the FRAP application software.

Show graph at acquisition: This option shows a graph window together for each phase.
At the end of the steps, a graph window will be shown regardless of this option.
Normally, this option is off.

In Spots / Out Spots: This option specifies settings of the side of bleaching, inside or outside of a spot.

ZOOM: This option changes the zooming magnification in the scan area of bleaching.

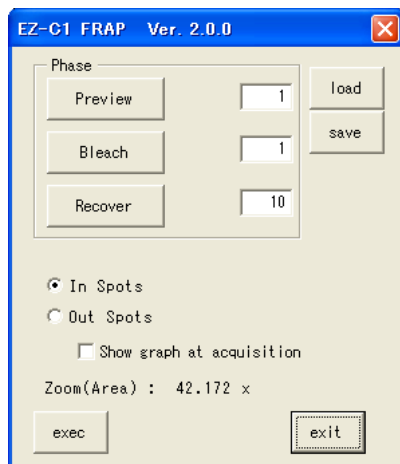

Note

You can use a specific wavelength to excite a specimen with the FRAP sequence macro described as follows: Set a wavelength for the “Preview” and “Recover” phase, and set another wavelength for the “Bleach” phase.

Example

In case that the wavelength of 405 nm is used to excite a specimen and the wavelength 488 nm is used to observe the specimen, specify as follows: Set the 488 nm for the “Laser Checkbox” of the “Preview” and “Recover” phase and set the 405 nm for the “Laser Checkbox” of the “Bleach” phase. This enables exciting a specimen instead of bleaching a specimen.

A.2 FLIP Sequence Macro

To perform the fluorescence loss in photobleaching (FLIP), carry out the following.
(Refer to 5.2.1, and specify the laser, AOM, and AOTF beforehand)

1 Check the settings of the laser, AOM, and AOTF

Refer to A.1, “FRAP Sequence Macro.” The same settings are used in the FLIP sequence.

2 Load the FLIP Sequence macro

For loading the macro file, refer to the head description of “A Experiment Sequence Macro.”

3 Set a spot

To set a spot, refer to A.1, “FRAP Sequence Macro.” The same operation is required in the FLIP sequence.

4 Specify the setting of bleaching on/off for the spot

To specify the setting of bleaching on/off for the spot, refer to A.1, “FRAP Sequence Macro.” The same operation is required in the FLIP sequence.

However, the FLIP sequence is not recommended for experiments that are intended to bleach wide areas and keep a part from bleaching like iFrap.

It is possible to perform such experiments but do not try.

5 Run the FLIP application software

Select “FLIP” in the “FRAP” menu.



CAUTION

- The FLIP sequence macro can be used in the standard mode and the spectrum mode. But, the FLIP sequence macro does not detect the mode change between the standard mode and the spectrum mode when running. Therefore, if the mode is changed, the macro issues a warning message and is aborted. To restore the system, select the menu and start the macro again.
- Do not run another macro when the FLIP sequence macro is running.

6 Select the PMT gain operation mode

Specify the PMT gain operation mode as “Linear Gain Mode” or not.

Usually, select the same mode as the PMT operation mode of the EZ-C1.

When the check box of “Show this dialog again” is checked, the macro runs with the PMT gain operation mode set above.

To display the dialog box again, delete the file below.

Program Files\Nikon\Shared\Projects\lineargain.ini

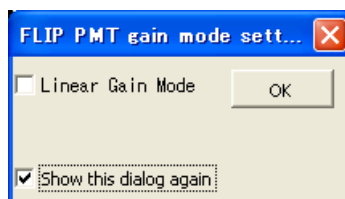

CAUTION

- The file, Program Files\Nikon\Shared\Projects\lineargain.ini, is used in the following three macros in common: the FRAP sequence macro, FLIP sequence macro, sequence macro for specimen excited with lights of two wavelengths but emitting a fluorescent light of one wavelength. Therefore, the “Show this dialog again” setting will be reflected to other sequence macros.

7 Display the FLIP application dialog box

The FLIP application dialog box appears.

In this window, specify the frame count for the “Preview” phase.

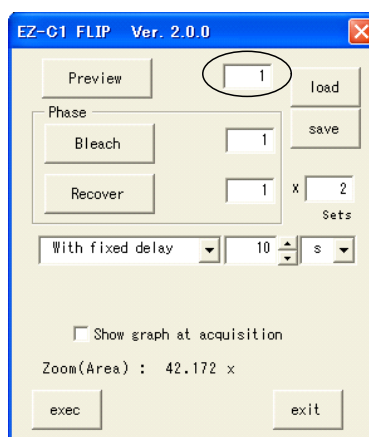

Note

- **[Preview]:** This is a phase to be performed before bleaching. Normally specify one frame.

8 Specify the “Preview” phase settings

Specify the “Preview” phase settings as follows:

A “Preview” phase starts when the [Preview] button on the FLIP application dialog box is pressed. The “preview setting” dialog box appears. The default settings are the same as the settings of EZ-C1. To change the settings, perform the followings: Press the [Live] button to show a live image. Check the image and specify each setting of “pixel dwell”, “laser”, and “gain.”

To capture several frames, specify the “Time series” option in the “interval (frame) time setting. (But, the “Variable Delay Mode” option cannot be used.)

To specify the settings, refer to A.1, “FRAP Sequence Macro.” The same operation is required in the FLIP sequence.

9 Specify the “FLIP Set” settings in the FLIP application software dialog box

Return to the FLIP application software dialog box. Set the “FLIP Set” settings in the box. Specify the frame counts for the “Bleach” phase and “Recover” phase in one set.

And then, specify the repeat count of sets.

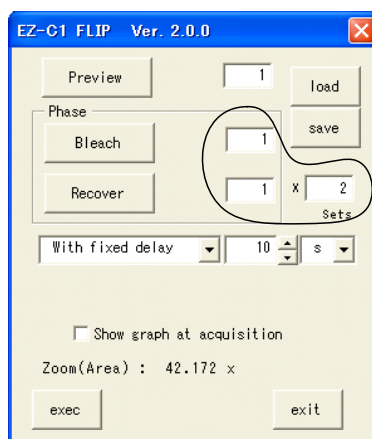

Note

- **[Bleach]:** This is a phase of bleaching. Normally specify one frame.
- **[Recover]:** This is a phase after bleaching to observe the recovering specimen. Normally specify one frame for a FLIP experiment.
- **[Sets]:** This is the repeat count of “Bleach” phases and “Recover” phases. Specify several frames for a FLIP experiment.

When the FLIP sequence macro runs, the following steps are executed: A “Preview” phase is executed. (It is shown as “Preview” in the figure below.) “Bleach” phases (shown as “Ble” in the figure below) and “Recover” phases (shown as “Acq” in the figure below) are repeated the number specified in the “Sets” option. Only images captured in the “Recover” phase are saved as experiment images. This sequence replicates a FLIP experiment practically.

The minimum processing period for one set is about one second. (It depends on the image size.)

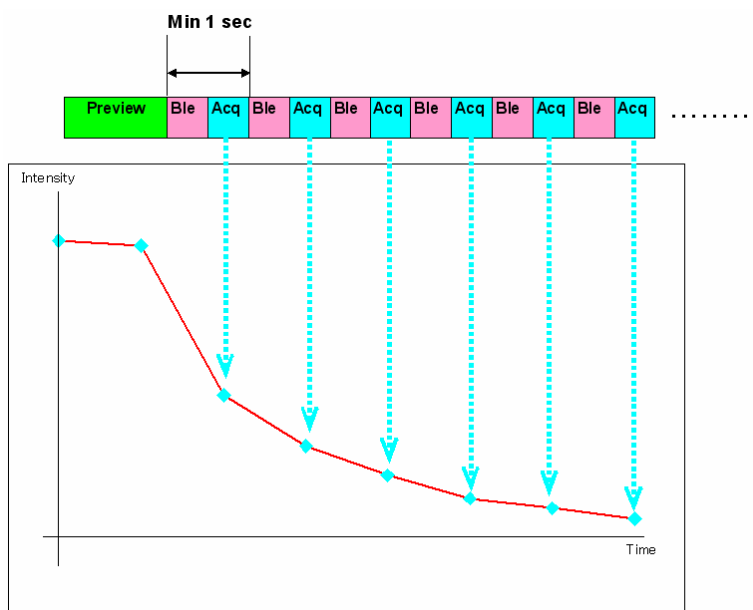

10 Specify the “Bleach” phase settings

Specify the “Bleach” phase settings as follows:

A “Bleach” phase starts when the [Bleach] button on the FLIP application dialog box is pressed. The “bleach setting” dialog box appears. Specify the “laser” and “gain” settings for the “Bleach” phase. The default settings are the followings: The “pixel dwell” value is the same as the “Preview” setting. All laser powers are “100%.” All gains are 0.

A “Scan zoom area selection [selected]” window also appears. Scan areas to be bleached are defined on this window. To define a scan area, create a rectangle with mouse operation. If no area is defined here, an area will be defined automatically where all spots are included.

To specify the settings, refer to A.1, “FRAP Sequence Macro.” The same operation is required in the FLIP sequence.

Note

- In some FLIP experiment, some “Spots” are defined for analysis, not only an area to be bleached but also another area in the cell to be bleached, an area used as a reference, and an area in the background.

When the automatic setting is used in this case, the area to be scanned for bleaching is set as a rectangle including all “Spots” and circumscribing them.

This area may be too large to be scanned for bleaching. To get more suitable area, set the scan area manually in the scan area setting window.

On the other hand, automatic bleach scan area setting like FRAP can be used when the following steps are performed: Only the “Spot” to be bleached are specified before the processing. And the “Spot” to be analyzed is specified after the processing.

11 Specify the “Recover” phase settings

Specify the “Recover” phase settings as follows:

A “Recover” phase starts when the [Recover] button on the FLIP application dialog box is pressed. The “recover setting” dialog box appears. Specify the “laser” and “gain” settings for the “Recover” phase. The default settings are same as that of the “Preview” phase.

To capture several frames in the “Recover” phase, specify the “Time series” option in the “interval (frame) time setting. (But, the “Variable Delay Mode” option cannot be used.)

To specify the settings, refer to A.1, “FRAP Sequence Macro.” The same operation is required in the FLIP sequence.

Note

- With the FLIP sequence macro, a time-lapse photographing can be performed that has “Sets”. A “Set” is defined as a combination of a “Bleach” phase and a “Recover” phase. Therefore avoid a time-lapse setting only with a “Recover” phase but use the default setting of “As fast as possible.”

12 Specify the time-lapse settings of the “FLIP Set” in the FLIP application software dialog box

Return to the FLIP application software dialog box. Specify the time-lapse setting of the “FLIP Set” in the dialog box. A time-lapse photographing is available by using the “FLIP Set.” The “FLIP Set” has a “Bleach” phase and a “Recover” phase in a set.

With these settings, the sequence will go as: “Bleach” phase -> “Recover” phase -> time-lapse waiting. (No time-lapse waiting is made between the “Bleach” phase and the “Recover” phase.)

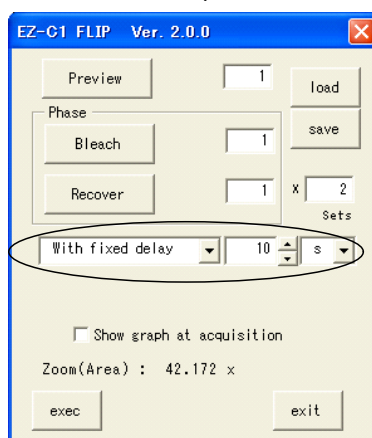

Note

- **interval (frame) time:** Select the “As fast as possible” option or the “With fixed delay” option. When the “With fixed delay” option is used, the time interval must be set with [ms] (milliseconds), [s] (seconds), or [m] (minutes). Normally this option is used in the FLIP Set time-lapse photographing. (When no time interval is required, select the “As fast as possible” option.)

13 Execute the FLIP sequence

After specifying settings for the “Preview”, “Bleach”, “Recover” phase, the “Flip Set” count, and the time-lapse photographing, press the [exec] button on the FLIP application software window to start a FLIP sequence. At first a “Preview” phase is processed. “Bleach” phases and “Recover” phases are repeated as specified in the “Set” option. Images are captured in each phase. And then, data in graphical form is displayed.

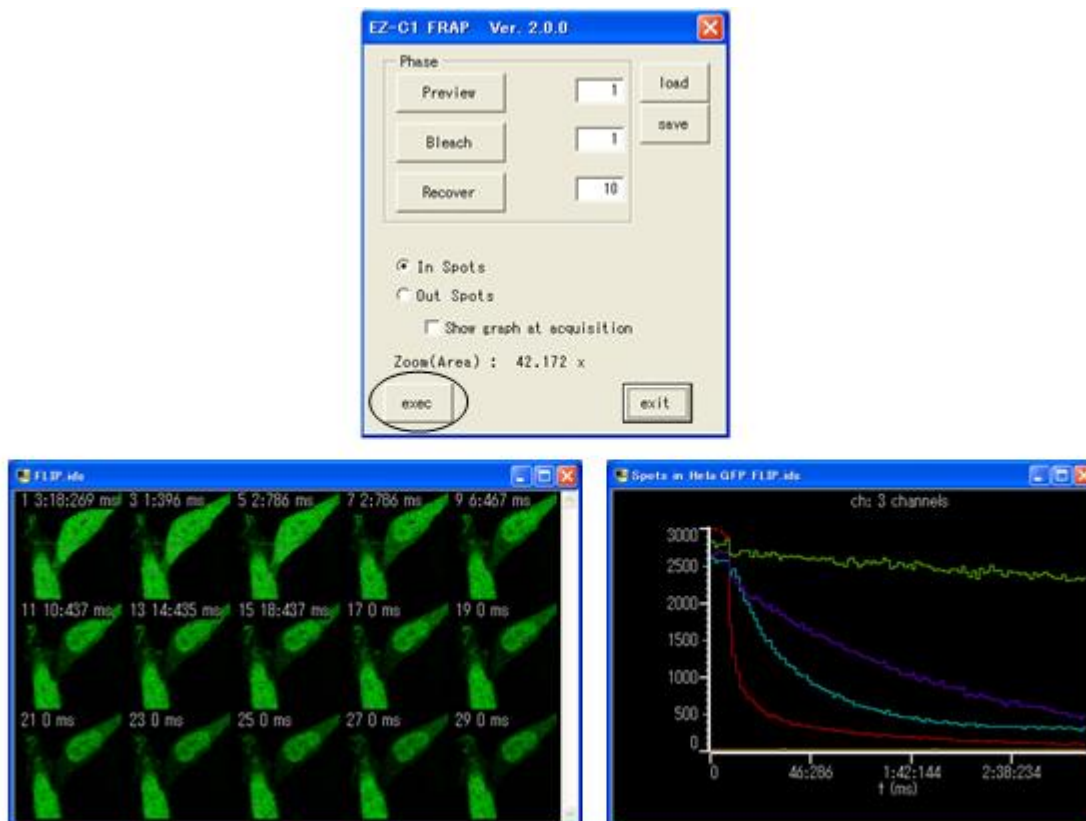

Note

When you use default settings for each phase, you can omit setting each phase. If you observe the specimen with EZ-C1, the settings of EZ-C1 will be copied to the settings of the “Preview” and “Recover” phases. And for the settings of the “Bleach” phase, the laser power will be set as “100%.” To perform a time-lapse photographing with the “As fast as possible” setting in a FLIP experiment, specify the image count on the FLIP application window and simply press the [exec] button.

Default settings for each phase are described as follows:

[Default settings of the “Preview” phase]

- **pixel dwell:** Set values in EZ-C1 are copied here.
- **laser checkbox:** All lasers are ON.
- **laser:** Set values in EZ-C1 are copied here.
- **gain:** Set values in EZ-C1 are copied here.
- **gain enable:** Enabled
- **interval (frame) time:** “As fast as possible”

[Default settings of the “Bleach” phase]

- **pixel dwell:** Set values for the “Preview” phase are copied here.
- **laser checkbox:** Selected lasers in step 1 “Check the settings of the laser, AOM, and AOTF” for bleaching are set as ON.
- **laser:** This entry is set as “100%.”

- **change Laser Power:** This check box is not checked.
- **gain:** This entry is set as "0."
- **gain enable:** Disabled
- **Scan area:** The scan area is set as a rectangle that circumscribes all spot areas.

[Default settings of the "Recover" phase]

- **same pre setting:** This check box is on. Normally, the setting for the "Recover" phase is set the same as the "Preview" phase.
- **pixel dwell:** Set values for the "Preview" phase are copied here.
- **laser checkbox:** Set values for the "Preview" phase are copied here.
- **laser:** Set values for the "Preview" phase are copied here.
- **gain:** Set values for the "Preview" phase are copied here.
- **gain enable:** Set values for the "Preview" phase are copied here.
- **interval (frame) time:** "As fast As possible"

[Default settings of the "FLIP Set"]

- **interval (frame) time:** "As fast as possible"

14 Other functions

The FLIP application software also has following functions.

[save] [load]: These functions save/load the settings of the FLIP application software.

Show graph at acquisition: This option shows a graph window together for each phase.

At the end of the steps, a graph window will be shown regardless of this option.

Normally, this option is off.

ZOOM: This option changes the zooming magnification in the scan area of bleaching.

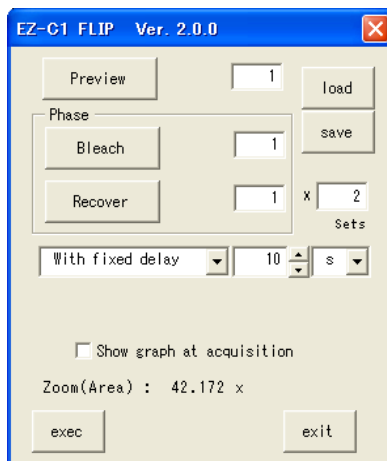

Note

You can use a specific wavelength to excite a specimen with the FLIP sequence macro described as follows: Set a wavelength for the "Preview" and "Recover" phase, and set another wavelength for the "Bleach" phase.

Example:

In case that the wavelength of 405 nm is used to excite a specimen and the wavelength 488 nm is used to observe the specimen, specify as follows: Set the 488 nm for the "Laser Checkbox" of the "Preview" and "Recover" phase and set the 405 nm for the "Laser Checkbox" of the "Bleach" phase. This enables exciting a specimen instead of bleaching a specimen.

A.3 2 Excitation 1 Emission Ratio Sequence Macro

“2 Extension 1 Emission” fluorescent experience method is used when the intensity of the emitted fluorescent light depends on the exciting laser wavelength. The wavelengths to excite the specimen are changed but the wavelength to be emitted from the specimen does not change.

To run the 2 Excitation 1 Emission, perform the following.

1 Load the 2 Excitation 1 Emission Ratio Sequence macro

For loading the macro file, refer to the head description of “A Experiment Sequence Macro.”

Note

- The 2 excitation 1 emission ratio sequence macro is provided on the CD-ROM disc. This macro is installed together with the EZ-C1 application software if the application software is installed using the EZ-C1’s integrated installer (All EZ-C1 3.80 Project).
The file is installed in a folder named Program Files\Nikon\Shared\Projects.

2 Start the fluorescence ratio application software

On the “Data” menu, point to “Calculate,” and then click “2Ex 1Em Ratio.”

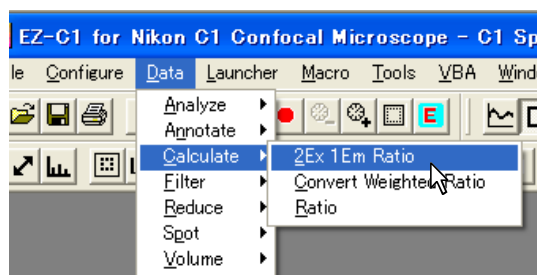

CAUTION

- The fluorescence ratio macro can be used only in the standard mode. If the system is running in the spectrum mode, this macro issues a warning message and is aborted. In that case, change the mode to the standard mode. And then select the macro on the menu to start it.
- Do not run another macro when the fluorescence ratio macro is running.

3 Select the PMT gain operation mode

Specify the PMT gain operation mode as “Linear Gain Mode” or not.

Usually, select the same mode as the PMT operation mode of the EZ-C1.

When the check box of “Show this dialog again” is checked, the macro runs with the PMT gain operation mode set above.

To display the dialog box again, delete the file below.

Program Files\Nikon\Shared\Projects\lineargain.ini

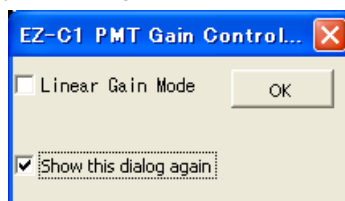

CAUTION

- The file, Program Files\Nikon\Shared\Projects\lineargain.ini, is used in the following three macros in common: the FRAP sequence macro, FLIP sequence macro, fluorescence ratio sequence macro for specimen excited with lights of two wavelengths but emitting a fluorescent light of one wavelength. Therefore, the "Show this dialog again" setting will be reflected to other sequence macros.

4 [Step 1] Select the channel to be acquired

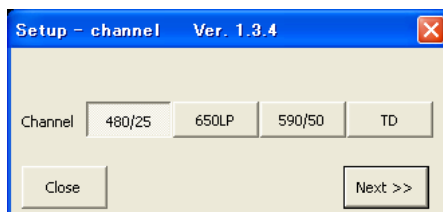

Select the channel to be acquired.
And then, press the [Next] button.

Note

- **[Channel] button:** These buttons select the channel to be acquired.
- **[Close] button:** This button stops and aborts the macro.
- **[Next >>] button:** This button proceeds to the next step.

5 [Step 2] Specify the laser used to excite the specimen (numerator of the ratio)

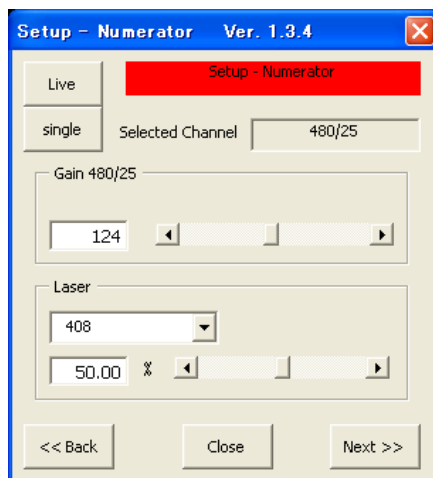

Specify the laser wavelength to excite the specimen. The value of this wavelength is used as a numerator of the ratio. And the gain of the channel that is used to acquire the intensity of the laser (numerator laser) can be set too.

Images can be previewed by pressing the [Live] or [single] button.

And then, press the [Next] button.

Note

- **[Live] button:** Press this button to display a live image. This function can be used to preview images when specifying the numerator laser to excite the specimen. This is the same function as the [Live] button in EZ-C1.
- **[single] button:** Press this button to capture single image. This function can be used to check an image when specifying the numerator laser to excite the specimen. This is the same function as the [Single] button in EZ-C1.
- **[Selected Channel]:** The selected channel name is displayed here.
- **[Gain]:** The PMT gain used to acquire the intensity of the numerator laser is specified here.
- **[Laser]:** The shutter of the numerator laser to excite the specimen is specified here. When one laser shutter is selected, other laser shutters are closed.



And, the numerator laser power to excite the specimen can be set too.

- **[<<Back] button:** Press this button to return to the previous step.
- **[Close] button:** Press this button to stop and abort the macro.
- **[Next >>] button:** Press this button to go to the next step.

6 [Step 3] Specify the laser used to excite the specimen (denominator of the ratio)

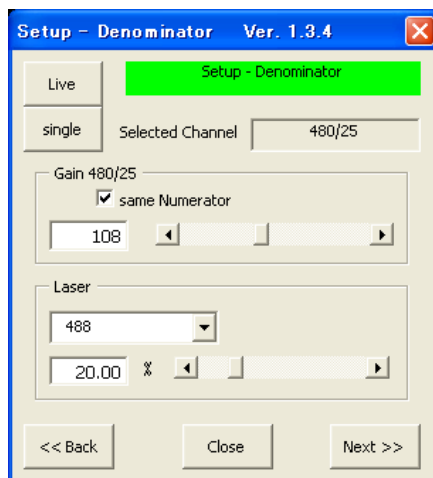

Specify the laser wavelength to excite the specimen. The value of this wavelength is used as a denominator of the ratio. And the gain of the channel that is used to acquire the intensity of the laser (denominator laser) can be set too. The default value is the same as the PMT gain value used in the [Step 2]. Images can be previewed by pressing the [Live] or [single] button. And then, press the [Next] button.

Note

- **[Live] button:** Press this button to display a live image. This function can be used to preview images when specifying the denominator laser to excite the specimen. This is the same function as the [Live] button in EZ-C1.
- **[single] button:** Press this button to capture single image. This function can be used to check an image when specifying the denominator laser to excite the specimen. This is the same function as the [Single] button in EZ-C1.
- **[Selected Channel]:** The selected channel name is displayed here.
- **[same Numerator]:** This check box is checked when the PMT gain setting for the denominator laser is the same as the setting for the numerator laser.
- **[Gain]:** The channel gain used to acquire the intensity of the denominator laser is specified here.
- **[Laser]:** The shutter of the denominator laser to excite the specimen is specified here. When one laser shutter is selected, other laser shutters are closed.



And, the denominator laser power to excite the specimen can be set too.

- **[<<Back] button:** Press this button to return to the previous step.
- **[Close] button:** Press this button to stop and abort the macro.
- **[Next >>] button:** Press this button to go to the next step.

7 [Step 4] Specify the time-lapse photographing settings

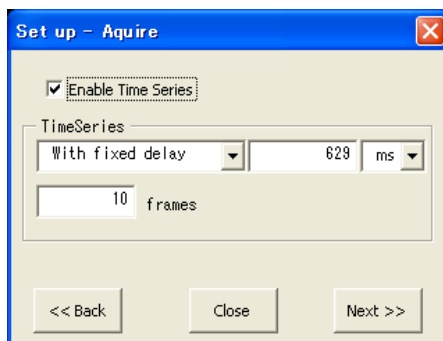

Specify the time-lapse photographing settings for the “Ratio Set.” The “Ratio Set” means one set of photographs that consist of a picture of the numerator laser step and a picture of the denominator laser step. Select one of the following three modes.

Acquisition mode	Settings
1. Only one set of the “Ratio Set” is acquired.	Do not check the “Enable Time Series.”
2. A series of “Ratio Sets” is acquired continuously.	Check the “Enable Time Series.” Select “As fast as possible” in the “Time Series” list. Specify the count of photographs.
3. A series of “Ratio Sets” is acquired at a specified time interval.	Check the “Enable Time Series.” Select “With fixed delay” in the “Time Series” list. Specify the time interval and the count of photographs.

And then, press the [Next] button.

Note

- **[Enable Time Series]:** Select this option to enable time-lapse photographing.
- **[Time Lapse Mode]:** Select a time-lapse photographing mode. Select the “As fast as possible” option or the “With fixed delay” option. The “With variable delay” option cannot be selected. It can be selected only when the “Enable Time Series” option is checked.
- **[Interval Time]:** Specify the time interval setting for the time-lapse photographing. It can be specified in units of milliseconds (ms), seconds (s), or minutes (m). As for the milliseconds, up to 5000 can be specified. As for the seconds and minutes, up to 300 can be specified. (Caution: If no image is acquired within the period specified here, the sequence will be aborted. Specify an enough value to acquire both photographs of one “Ratio Set.” This setting can be specified only when the “Enable Time Series” option is checked and the “With fixed delay” is selected in the “Time Lapse Mode.”
- **[Frames]:** The count of the “Ratio Set” for the time-lapse photographing is specified here. It can be selected only when the “Enable Time Series” option is checked.
- **[<<Back] button:** Press this button to return to the previous step.
- **[Close] button:** Press this button to stop and abort the macro.
- **[Next >>] button:** Press this button to go to the next step.

8 [Step 5] Select the calculation method to get the ratio

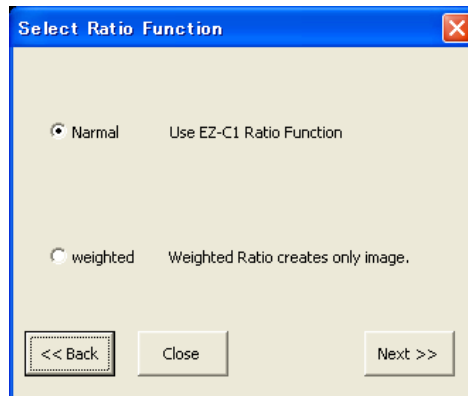

Select the calculation method to get the ratio

The following two methods are available.

Normal ratio calculation method The normal calculation method used in EZ-C1.
The settings are specified in EZ-C1.

Weighted ratio calculation method This is a special calculation method. Pixels are weighted in accordance with their brightness. Therefore, brightness information that might be ignored in the normal calculation method will be reflected to the calculation result. (The brightness information of the denominator laser channel is used with this method.)

CAUTION

- When the Weighted ratio calculation method is used, image data is output as RGB 24 bits data after calculation. Therefore, no ratio information remains in the image data after calculation. And no ratio analysis can be performed using "Spots."
- To perform a ratio analysis, select the Normal ratio calculation method.

And then, press the [Next] button.

When the Normal ratio calculation method is selected, go to Step 7.

When the Weighted ratio calculation method is selected, go to Step 6.

Note

- **[Ratio calculation method]:** Select the ratio calculation method to be used.
- **[<<Back] button:** This button returns the step to the previous step.
- **[Close] button:** This button stops and aborts the macro.
- **[Next >>] button:** This button proceeds to the next step.

9 [Step 6] Specify the settings for the Weighted ratio calculation method

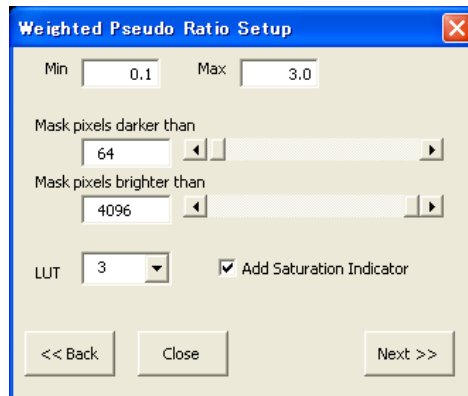

Specify the parameters used in the Weighted ratio calculation method. In this calculation, pixel data are converted to RGB 24 bits data by using a look-up table that has data to assign weights to pixels. And then, press the [Next] button.

Note

- **[Min]:** Specify the minimum value of ratios for the look-up table.
- **[Max]:** Specify the maximum value of ratios for the look-up table.
- **[Mask pixels darker than]:** When brightness of a pixel is darker than this value, the pixel is set as black in the Weighted ratio calculation.
This option is used to remove background noise.
- **[Mask pixels brighter than]:** When brightness of a pixel is darker than this value, the pixel is set as black in the Weighted ratio calculation.
This option is used to remove pixels that have saturated values (or that have values near saturation).
- **[LUT]:** Select a look-up table that has the suitable weighting values for pixels. Six look-up tables are available. They have a different gamma correction curve.
- **[Add Saturation Indicator]:** This check box is checked to display special colors of pixels that have values less than "Min" or larger than "Max." When this check box is not checked, the pixel that has a smaller value than "Min" is displayed the same color as that of the "Min" value and the pixel that has a larger value than "Max" is displayed the same color as that of the "Max" value. When this check box is checked, the pixel that has a smaller value than "Min" is displayed as cyan and the pixel that has a larger value than "Max" is displayed as pink.
- **[<<Back] button:** Press this button to return to the previous step.
- **[Close] button:** Press this button to stop and abort the macro.
- **[Next >>] button:** Press this button to go to the next step.

10 [Step 7] Acquire the data and display the result

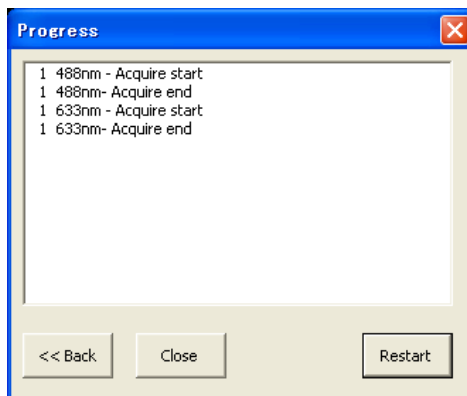

When this dialog box is displayed, the data acquisition starts. During the data acquisition, text-based information is displayed in the dialog box.

When the "Ratio Set" acquisition is completed, each captured image is displayed on EZ-C1 as an image of a separate channel. This data can be handled as the same way as a fluorescence ratio experiment.

At the same time, a ratio image is displayed on the Ratio window.

When the Normal ratio calculation method is used, the ratio image can be handled as the same way as a ratio calculation in EZ-C1.

(For settings about the Normal ratio calculation method, refer to 4.3.3, "Calculate (Ratio).")

When the Weighted ratio calculation method is used, the ratio image in the Ratio window has RGB 24 bits data. This image cannot be handled as a ratio image of EZ-C1. Be aware of it.

CAUTION

- Be sure to save the acquired image. (Not the ratio image) When the acquired image is kept, it can be handled as the same way as a fluorescence ratio experiment. It can be used not only in the Normal ratio calculation but also in the "Convert Weighted Ratio" macro to create a Weighted ratio image.

This is the end of the fluorescence ratio macro sequence.

To finish the macro, press the [Close] button. To acquire another image, press the [Restart] button.

Note

- **[Photograph information]:** During the data acquisition of "Ratio Sets," text-based information is displayed in the dialog box. Four statuses are displayed here: "Acquire start" to show the start of acquiring one frame, "Acquire end" to show the end of acquiring one frame, "Finish" to show the end of acquiring all "Ratio Sets", and "Error" to show an error occurrence.
- **[<<Back] button:** Press this button to return to the previous step.
- **[Close] button:** Press this button to stop and abort the macro.
- **[Restart] button:** Press this button to acquire another image with the same settings. To change the settings, press the [<<Back] button to go to the corresponding step.

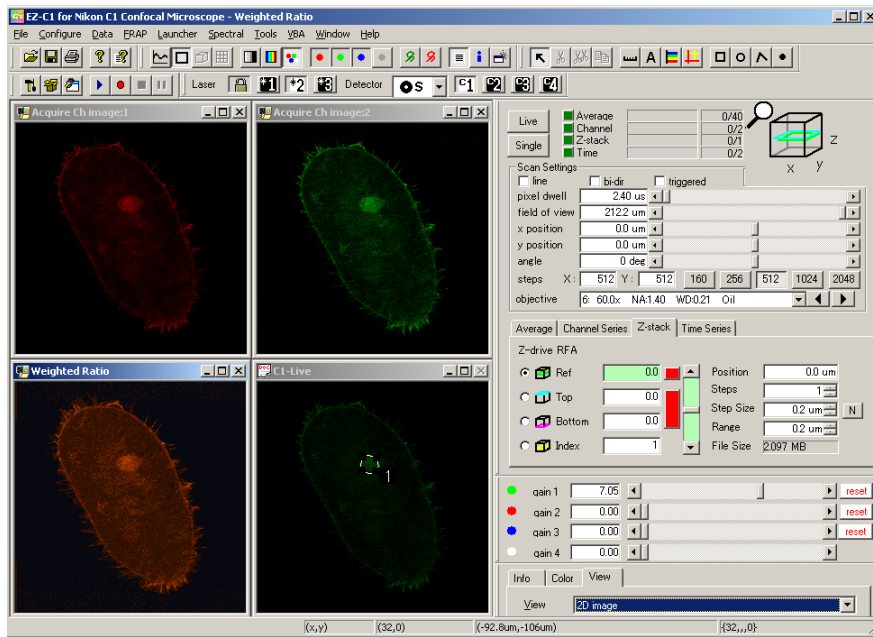

During the data acquisition, four images are displayed in the window: an image of the numerator laser channel, an image of the denominator laser channel, a ratio image, a live image (latest image acquired).

11 Weighted ratio conversion macro

The weighted ratio conversion macro is used to calculate a weighted ratio operation from multiple channel images captured already and create a weighted ratio image.

In the fluorescence ratio sequence macro, the weighted ratio operation settings cannot be changed without capturing images again. And captured images cannot be converted to weighted ratio images after the processing.

In such case, use this macro to convert captured images to weighted ratio images.

This macro is also useful for other multiple channel images than images acquired with the fluorescence ratio macro.

On the “Data” menu, point to “Calculate,” and then click “2Ex 1Em Ratio.”

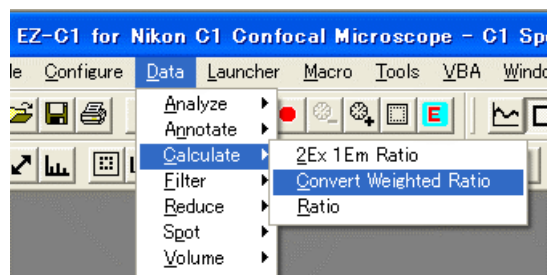

The weighted ratio conversion macro starts.

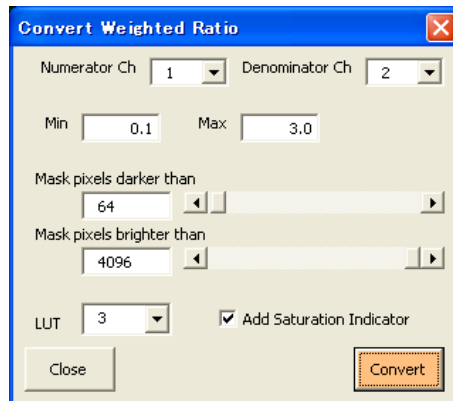

Specify each setting and press the [Convert] button to show a ratio image that has calculated values of the weighted ratio operation.

CAUTION

- When the Weighted ratio calculation method is used, image data is output as RGB 24 bits data after calculation. Therefore, no ratio information remains in the image data after calculation. And no ratio analysis can be performed using "Spots."

Note

- **[Numerator Ch]:** Specify a channel that is used for the numerator data. This channel can be set freely. Not only the channel that was specified as the numerator at the time of acquisition but also all channel can be set here.
- **[Denominator Ch]:** Specify a channel that is used for the denominator data. This channel can be set freely. Not only the channel that was specified as the denominator at the time of acquisition but also all channel can be set here.
- **[Min]:** Specify the minimum value of ratios for the look-up table.
- **[Max]:** Specify the maximum value of ratios for the look-up table.
- **[Mask pixels darker than]:** When brightness of a pixel is darker than this value, the pixel is set as black in the Weighted ratio calculation.
This option is used to remove background noise.
- **[Mask pixels brighter than]:** When brightness of a pixel is darker than this value, the pixel is set as black in the Weighted ratio calculation.
This option is used to remove pixels that have saturated values (or that have values near saturation).
- **[LUT]:** Select a look-up table that has the suitable weighting values for pixels. Six look-up tables are available. They have a different gamma correction curve.
- **[Add Saturation Indicator]:** This check box is checked to display special colors of pixels that have values less than "Min" or larger than "Max." When this check box is not checked, the pixel that has a smaller value than "Min" is displayed the same color as that of the "Min" value and the pixel that has a larger value than "Max" is displayed the same color as that of the "Max" value. When this check box is checked, the pixel that has a smaller value than "Min" is displayed as cyan and the pixel that has a larger value than "Max" is displayed as pink.
- **[Close] button:** Press this button to stop and abort the macro.
- **[Convert] button:** Press this button to start the weighted ratio operation.

A.4 Multipoint Time-lapse Macro

The multipoint time-lapse macro is used to capture images at several arbitrary positions with specified time-lapse settings.

Multipoint time-lapse macro now supports the following functions.

- Spectral Frame Lambda Series Manual Filter mode
- Time-lapse image acquisition for transmission detector under the spectral mode
- Average image acquisition under the spectral mode

The multipoint time-lapse macro is available with the following hardware and functions.

- Motorized XY stage for Ti-E microscope
- Prior Proscan2 motorized XY stage
- Perfect Focus System
- Interlock operation with observation modes of "Average," "Channel Series," and "Z-Stack."

Images can be acquired in the following four sequences.

- 1) [Multi-Point] → Time Series
 - 2) Frame Ch → [Multi-Point] → Time Series
 - 3) Z-Stack → [Multi-Point] → Time Series
 - 4) Frame Ch → Z-Stack → [Multi-Point] → Time Series
- Normal mode and spectrum mode

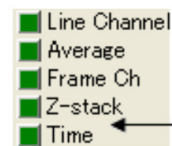

Images are acquired in the following order:
Z-stack, Multi-Point,
Time Series

CAUTION

The settings for each observation mode ("Average," "Channel Series," or "Z-Stack" mode) are specified in EZ-C1 (not in this macro).

1 Specify devices

The multipoint time-lapse macro supports the following devices:

Devices supporting [Multi Point Timelapse using XY-Stage Control] and [Multi Point Timelapse in field of view]

- Ti-E microscope + Motorized XY stage
- TE2000-E microscope + Prior ProScan2 XY Stage without Z-Drive
- TE2000-U/S microscope + Prior ProScan2 XY Stage without Z-Drive

Devices supporting [Multi Point Timelapse in field of view] only

- 90i microscope
- Z-drive RFA (when using a manual microscope)

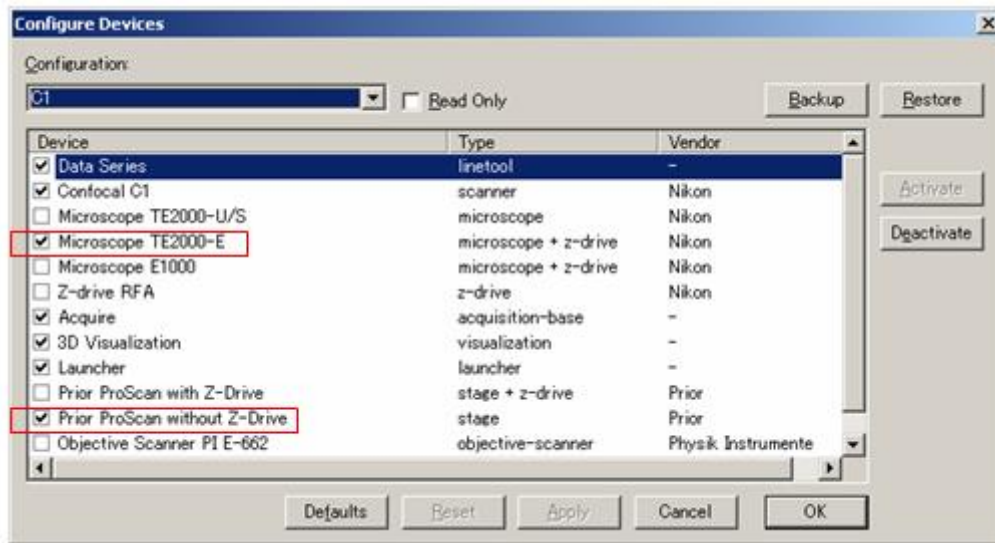
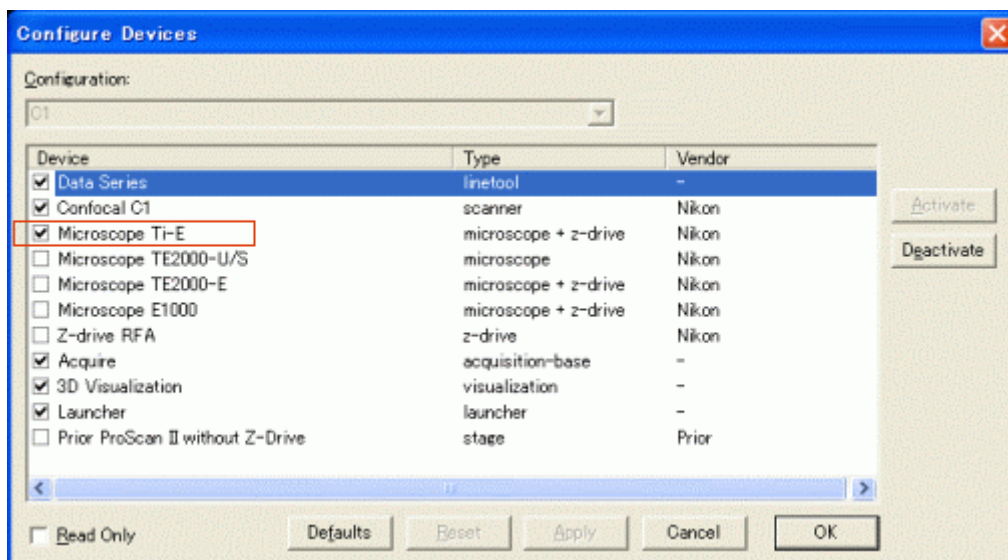

Figure A.4-1 Configure Devices dialog box

In case of using the TE2000 microscope, connect the PC, microscope, and Prior ProScan 2 motorized XY stage, and then select “Microscope TE2000-E” and “Prior ProScan without Z-Drive” on the Configure Devices dialog box.



In case of using the Ti-E microscope, connect the PC, microscope, and motorized XY stage, and then select “Microscope Ti-E” on the Configure Devices dialog box.

CAUTION

When the Nikon Perfect Focus System (PFS) is used with the TE2000-E, the “Z-Stack” settings have special limitations.

1. The PFS does not work with the “Z-Drive” function together.
2. When an image is captured using the “Z-Stack” function, the focusing control on the PFS will be released.

2 Load the multipoint time-lapse macro

For loading the macro file, refer to the head description of “A Experiment Sequence Macro.”

Note

- The Multipoint Time-lapse macro file is provided on the CD-ROM disc. This macro is installed together with the EZ-C1 application software if the application software is installed using the EZ-C1's integrated installer (All EZ-C1 3.80 Project).
The file is installed in a folder named Program Files\Nikon\Shared\Projects.

3 Run the multipoint time-lapse application software

Select “MultiPoint” on the “Time Lapse” menu.

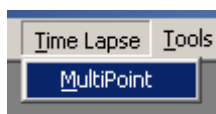

- When a motorized XY stage is connected, the screen for multipoint time-lapse mode selection is displayed. Select [Multi Point Timelapse using XY-Stage Control] or [Multi Point Timelapse in field of view].

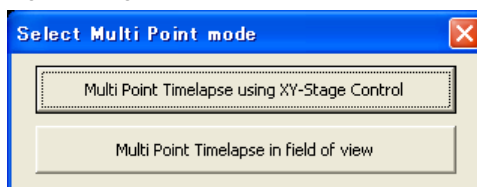

Multi Point Timelapse using XY-Stage Control: Enables observation of points coordinated to XY stage movement.

Multi Point Timelapse in field of view: The XY stage remains fixed, and multi-point observation in the field of view is enabled.

CAUTION

- If a motorized XY stage is not connected, [Multi Point Timelapse in field of view] is automatically initiated.
- The multipoint time-lapse macro can be used in the standard mode and the spectrum mode. But, the multipoint time-lapse macro does not detect the mode change between the standard mode and the spectrum mode when running. Therefore, if the mode is changed, the macro issues a warning message and is aborted. To restore the system, select the menu and start the macro again.
Do not run another macro when the multipoint time-lapse macro is running.

4 Image capturing setting

The dialog box below appears when the multipoint time-lapse macro starts.

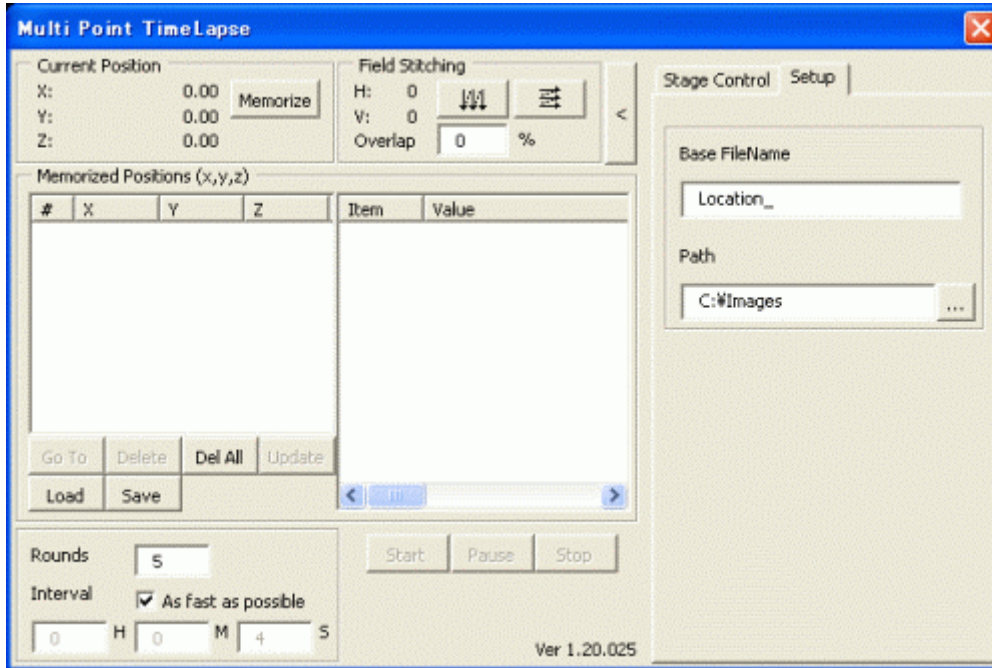

In the Setup tab in the image capturing settings, you can specify the destination folder and file name for acquired time-lapse images. Use the “Stage Control” tab to control the XY stage. (With “Multi Point Timelapse in field of view,” the observation area moves within the field of view.)

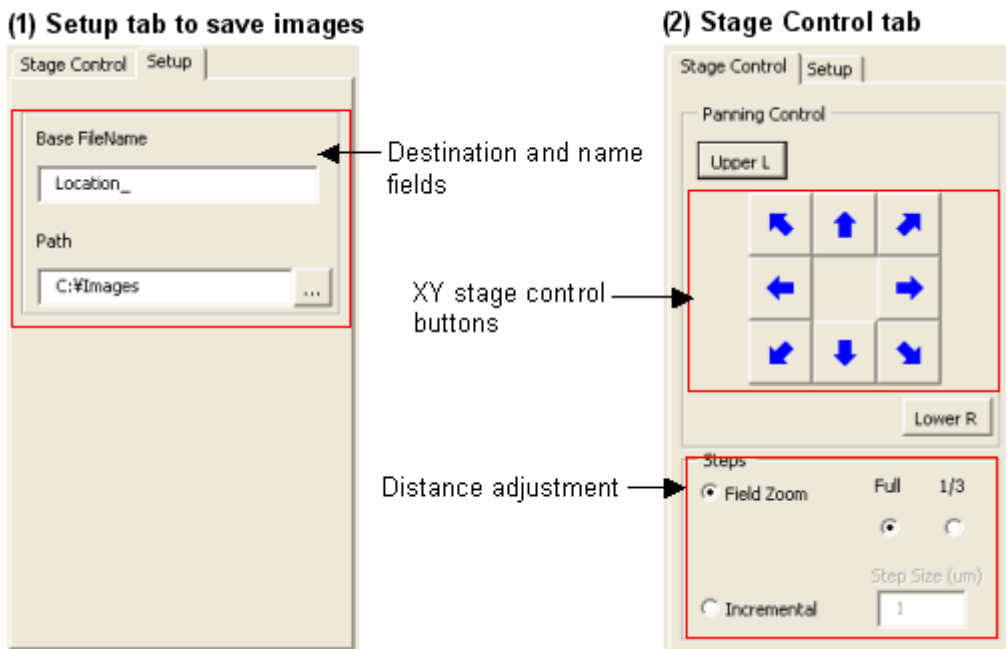

When “Multi Point Timelapse in field of view” is initiated, the corresponding dialog box is displayed at the same time as the Navigation window. Use both to specify observation points.

Note

- In the Acquire Settings dialog box, you can also specify lines as observation points by clicking the line scan button.

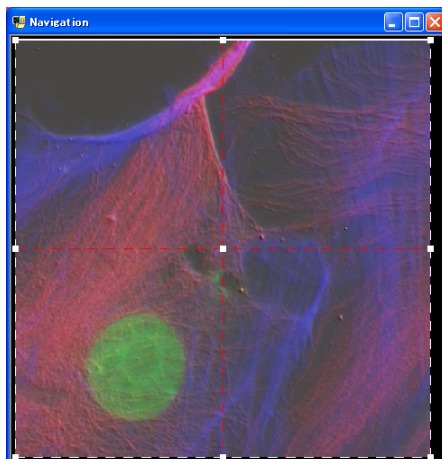

(1) Setup tab to save images

Specify the file name and folder name to save image data.

Name	Function Overview
Base FileName	Enter the file name of the captured time-lapse image.
Path	Enter the folder name with its file path to save files.

(2) Stage Control tab

Move the stage to specify areas for multipoint observation.

Name	Function Overview
XY stage control button	Move the XY stage with these buttons.
[Upper L] <i>(Enabled only when using Multi Point Timelapse using XY-Stage Control)</i>	<p>Press this button to specify the upper left position in a large area that consists of many sub-areas. The sub-area has the same size as the area displayed as the Field zoom area (field of view). When this button is pressed, the current position of the Field zoom area is set as the upper left position of the large area.</p> <div style="text-align: center;"> </div> <p>! [Memorize] in the Field Stitching group When [Upper L] and [Lower R] are set, the horizontal and vertical area count are displayed in the H (horizontal direction) and V (vertical direction) of the Field Stitching area. And the [Memorize] button is enabled.</p>

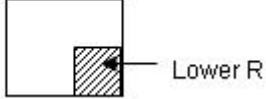
<p>[Lower R] (Enabled only when using Multi Point Timelapse using XY-Stage Control)</p>	<p>Press this button to specify the upper left position in a large area that consists of many sub-areas. The sub-area has the same size as the area displayed as the Field zoom area. When this button is pressed, the current position of the field of view is set as the lower right position of the large area. (The current field of view is included in the large area.)</p>  <p>! [Memorize] in the Field Stitching group</p> <p>When [Upper L] and [Lower R] are set, the horizontal and vertical area counts are displayed in the H (horizontal direction) and V (vertical direction) of the Field Stitching area. And the [Memorize] button is enabled.</p>
<p>Field Zoom (field of view)</p>	<p>When this option is selected, the traveling distance for each click of the XY stage control buttons is defined as follows:</p> <p>Full: one sub-area (the size of the Field zoom area)</p> <p>1/3: one-third distance of a sub-area (the size of the Field zoom area)</p>
<p>Incremental</p>	<p>When this option is selected, the traveling distance for each click of the XY stage control buttons is specified in micrometers.</p>

5 Observation point setting

The observation area specified on the stage control tab can be registered as a “Multipoint” area. In the multipoint time-lapse observation, these registered areas are used. The stage moves to observe each registered area automatically.

[Memorize] button: Registers the current observation area as a set of observation points. Information describing the registered points is indicated in the Memorized Positions list. For “Multi Point Timelapse in field of view,” observation points are specified in the Navigation window.

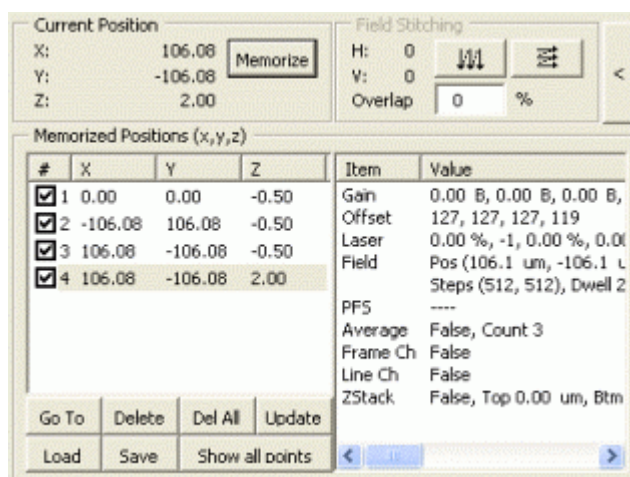

[Save] button: Saves the registered area data into a file.

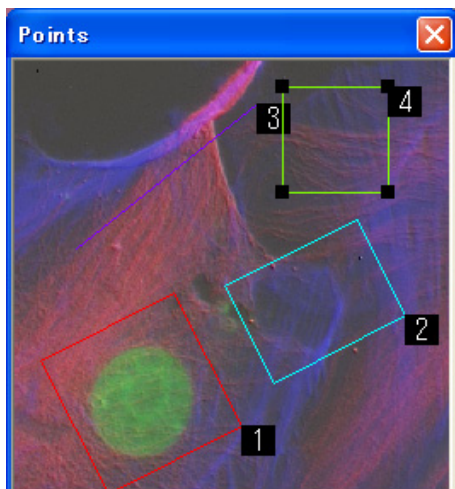

When you are registering observation points for “Multi Point Timelapse in field of view” using the Navigation window, the Points window is displayed for viewing the scan area.

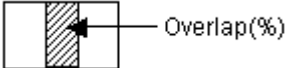

Name	Function Overview
<p>Current Position area</p> <p>The scan start point (upper left) of the current Field zoom area (field of view) is displayed in the X, Y, and Z field.</p>	
<p>[Memorize]</p>	<p>Press this button to register the point to acquire image data. The current Field zoom area data and the settings of each observation mode are registered into the “Memorized Positions” list.</p> <p>! Data registered with the “Memorize” function</p> <p>Position (X, Y, Z)</p> <p>Laser power</p> <p>Gain value</p> <p>Offset value</p> <p>Offset position of the PFS (only when PFS is used)</p> <p>Field zoom area data (X, Y position, Steps, Dwell Time)</p> <p>Average information (mode on/off, Count)</p> <p>Frame Lambda information (mode on/off, setting to each pass)</p> <p>Z-Stack data (mode on/off, Top, Reference, Bottom position)</p> <p>Line Mode</p> <p>Laser & Detector setting (during the Spectral mode)</p> <p>Spot on Live Window (only for stage moving multipoint)</p>
<p>Field Stitching area</p>	<p>This area is provided to specify a large area that has sub-areas. One sub-area is the same size as the current Field zoom area (field of view).</p> <p>In the H and V field, total counts of sub-areas are displayed.</p>

  Memorize <i>(Enabled only when using Multi Point Timelapse using XY-Stage Control)</i>	<p>This button is used to register points that are used to specify a large area consisting of sub-areas.</p> <p>To specify how to arrange the square areas, select the [Memorize] button in registration.</p> <p>! The memorize function is enabled only when the large area is defined with the [Upper L] and [Lower R] buttons on the stage control tab.</p> <p>! Field Stitching functions are not available with the macro for “Multi Point Timelapse in field of view”.</p>
Overlap	<p>Specify the extent of overlap of scan areas when points are arranged in a tiled display.</p> 
<p>Memorized Positions (X,Y,Z) area In this area, points for the multipoint observation and data of each point are displayed.</p>	
Check box	<p>When the check box of a position is checked, an observation is performed at the position in the multipoint time-lapse observation.</p> <p>On: observed point Off: not observed point</p>
[Goto]	<p>Move the stage to the position where the cursor is sitting. Registered conditions to observe an image are also restored.</p>
[Delete]	<p>Delete the position where the cursor is sitting.</p>
[Del All]	<p>Delete all registered positions.</p>
[Update]	<p>Overwrite the registered data of the position where the cursor is sitting. The current settings to observe an image are registered in place.</p>
[Load]	<p>Load the data file (.pos) of positions and restore the conditions.</p> <p>! Files you save when using an XY stage in multipoint observation can only be loaded when you start multipoint observation using an XY stage. Similarly, files you save in multipoint observation in the field of view can only be loaded for multipoint observation in the field of view.</p>
[Save]	<p>Save the registered data into a file (.pos).</p>
[Show all points] <i>(Enabled only when using Multi Point Timelapse in field of view)</i>	<p>When “Multi Point Timelapse in field of view” is active, scan areas for stored positions are displayed in the Points window.</p>

CAUTION

- If positions of the stage are reset or registered again, saved X, Y, and Z positions in the file cannot be restored any more. Be careful.
- Display of the scan area in the Points window is based on the initial view magnification of the Navigation window. Thus, keep in mind that if you change the view magnification of the Navigation window (in Zoom) before switching to another display area, the scan area of stored positions cannot be accurately reproduced.
- Frame Lambda observation settings for point information file saved with Ver1.40 or earlier of Multipoint Macro cannot be reproduced with EZ-C1 Ver3.80. (Frame Lambda observation settings can be reproduced for point information files saved with Ver1.40.)

6 Time-lapse setting

Specify time-lapse settings for a multipoint observation. Time interval (Interval) and repeat count (Rounds) for positions can be set.

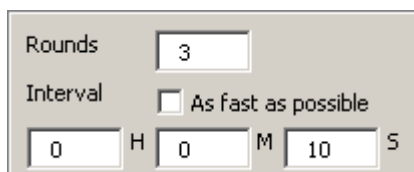

Name	Function Overview
Rounds	Specify the photographing count
As fast as possible	Repeat the image capturing as fast as possible.
Interval	Specify the time interval between image capturing sequences. ! The "Interval" value is the time interval from the start point of one observation sequence to the start point of another observation sequence.

7 Data acquisition control

Start the multipoint time-lapse observation.

Press the [Start] button to start an observation sequence. Observations of registered points are performed sequentially.

If the [Pause] button is clicked during the observation sequence, the observation is stopped temporarily. During the temporal stop, settings of observation points can be changed.



Name	Function Overview
[Start]	Start the time-lapse observation.

[Pause]	<p>Stop the observation temporarily.</p> <p>! Observation position data update The observation position data can be updated with the “Update” function of the “Memorized Positions” list. The registered data of the position where the cursor is sitting in the “Memorized Positions” list is overwritten. The current settings to observe an image are registered in place.</p>
[Stop]	<p>Abort the time-lapse observation.</p>

A.5 FRET Sequence Macro

To perform the fluorescence resonance energy transfer (FRET) sequence macro perform the following.

1 Load the FRET Sequence macro

For loading the macro file, refer to the head description of “A Experiment Sequence Macro.”

Note

- The FRET sequence macro file is provided on the CD-ROM disc. This macro is installed together with the EZ-C1 application software if the application software is installed using the EZ-C1’s integrated installer (All EZ-C1 3.80 Project).
- The file is installed in a folder named “Program Files\Nikon\Shared\Projects.”

2 Start the FRET application software

On the FRET menu, click on the “FRET Wizard.”



CAUTION

- The FRET sequence macro can be used in the standard mode and the spectrum mode.
- Do not run another macro when the FRET sequence macro is running.

3 Perform the FRET experiment

To capture images for the calculation of the FRET efficiency, select the “Acquisition” option. And click the [Next>>] button.

To calculate the FRET efficiency of existing FRET experiment data, select the “Analysis” option.

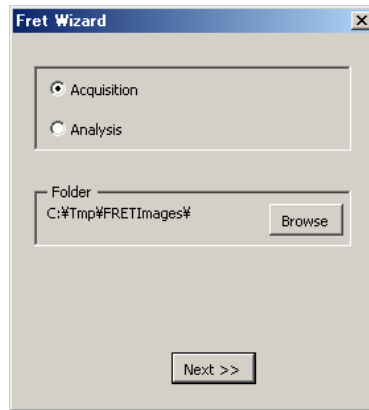

Note

- For the “Analysis” option, refer to Step 13, FRET data analysis.
- To change the destination for FRET image data, press the [Browse] button.

4 Experiment settings

Select the experiment setting method to perform the FRET sequence.

To add data to an existing experiment data, select the “Stored FRET Setup” option.

To create new settings, select the “New FRET Setup” option. When this option is selected, lasers to excite a specimen and the acquisition channels must be specified.



Note

- When the “stored FRET Setup” option is selected, the below dialog box appears. Select the experiment name to be used and press the [To Acquisition] button. Go to Step 10, “Capture the “Donor” image.”

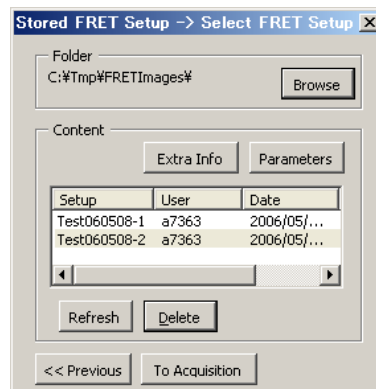

5 Select the setting method

When the “New FRET Setup” option is selected, a new setting can be created.

When the “Based on current setup” option is selected, an existing setting in EZ-C1 is used as a base to create a new setting.

When the “Based on stored setup” is selected, a saved setting is used as a base to create a new setting.

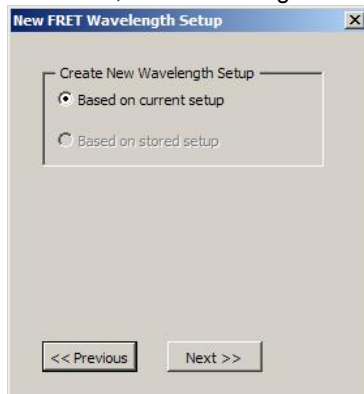

Note

- When the “Based on stored setup” option is selected, the below dialog box appears. Select the experiment name to be used and press the [To Edit Setup] button.

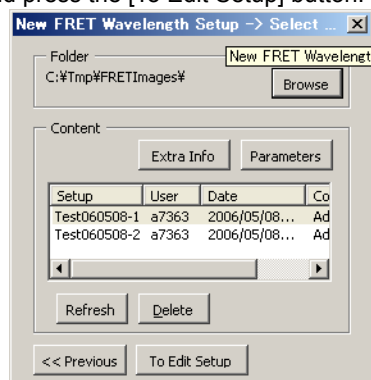

[Extra Info]: Edit the settings of the experiment.

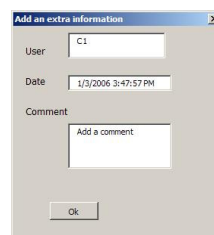

[Delete]: Delete the experiment settings.

[Parameters]: Verify the parameters used in the experiment.

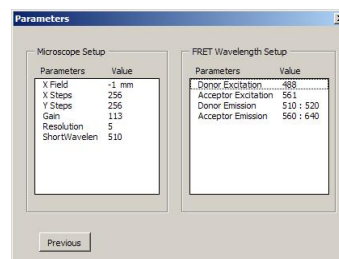

[Refresh]: Refresh the experiment names in the specified folder.

- !** To import FRET image data or settings of an experiment in other folder, copy the whole required folder to the specified folder. (Image data is saved to the folder specified in step 9 “Save the settings”.)

6 Specify the lasers to excite a specimen and the channel to acquire data

Specify the lasers to excite a specimen and the channels to acquire data.

[For the spectrum mode]

Specify the laser to excite the “Donor” and the laser to excite the “Acceptor.”

Specify the wavelengths of the “Donor” fluorescence and the “Acceptor” fluorescence to the detector.

[For the standard mode]

Specify the laser to excite the “Donor” and the laser to excite the “Acceptor.”

Specify the channel that is used for the “Donor” fluorescence and the channel that is used for the “Acceptor” fluorescence.

7 Specify the data acquisition setting method

Specify the data acquisition setting method.

To use the settings in EZ-C1, select the “Current setup of microscope” option.

To use the currently selected experiment settings, select the “Setting stored with current FRET setup.”

Following settings are copied: X field (field zoom of the field of view), X step (pixel count in the X-direction), Y step (pixel count in the Y-direction), Gain, Resolution of the spectrum detector, shortest wavelength of the spectrum detector.

Note

- When the “Current setup of microscope” is selected and gain settings for the donor and the acceptor are different in Step 8. “Test the setting,” the gain setting for the donor will be applied to the gain setting for the acceptor.

8 Test the settings

Test the settings to acquire images of the “Donor” and “Acceptor.”

To show the “Donor” image, press the [Test Donor] button. You can adjust the laser power and gain here. To finish the “Donor” image, press the [Stop Capturing] button.

To show the “Acceptor” image, press the [Test Acceptor] button. To finish the “Acceptor” image, press the [Stop Capturing] button.

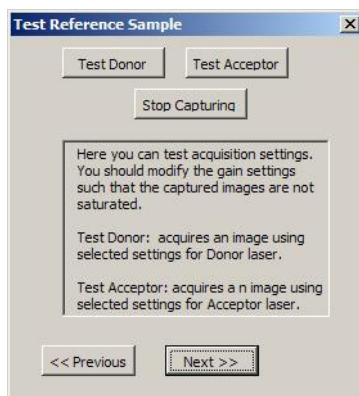

9 Save the settings

Save the settings into a file. Enter its name into the entry.

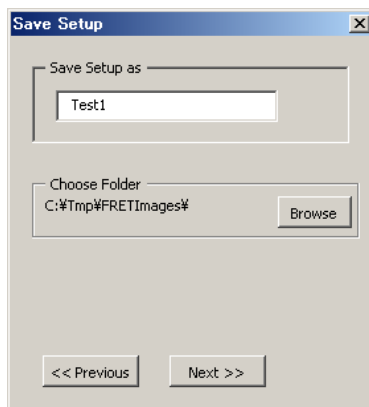
**Note**

- To change the destination for FRET image data, press the [Browse] button.

10 Capture the “Donor” image

Capture the “Donor” image.

On the “Donor Sample” tab, press the [Acquire] button. An image excited by the “Donor” laser and an image excited by the “Acceptor” laser is captured. If necessary, multiple images can be captured.

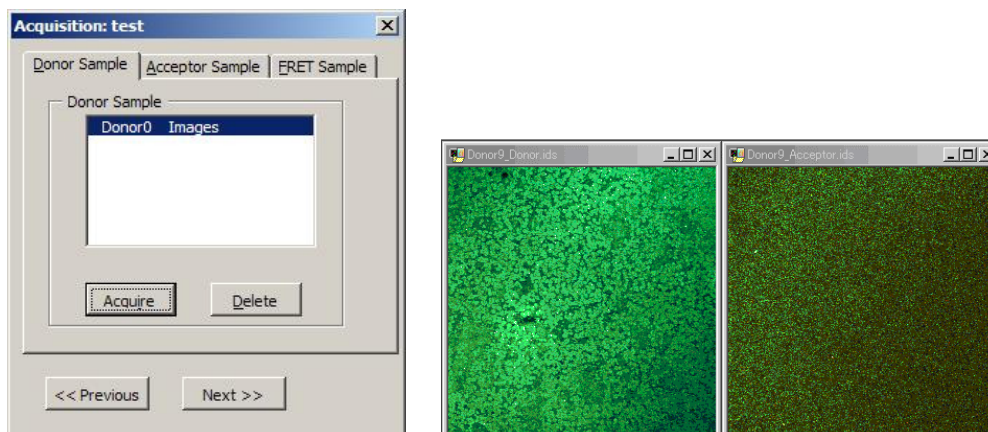

11 Capture the “Acceptor” image

Capture the “Acceptor” image.

On the “Acceptor Sample” tab, press the [Acquire] button. An image excited by the “Donor” laser and an image excited by the “Acceptor” laser is captured. If necessary, multiple images can be captured.

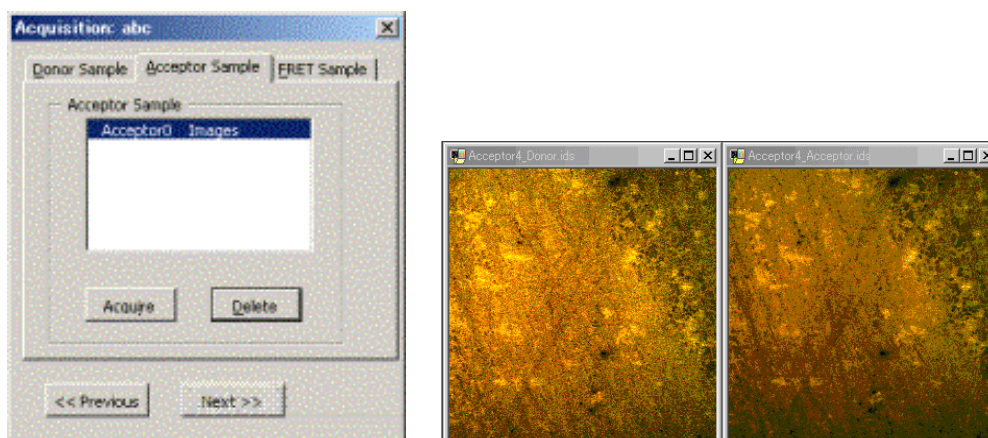

12 Capture the FRET image

Capture the FRET image.

On the “FRET Sample” tab, press the [Acquire] button. An image excited by the “Donor” laser and an image excited by the “Acceptor” laser is captured. If necessary, multiple images can be captured.

To calculate the FRET efficiency using the captured images, press the [Next>>] button.

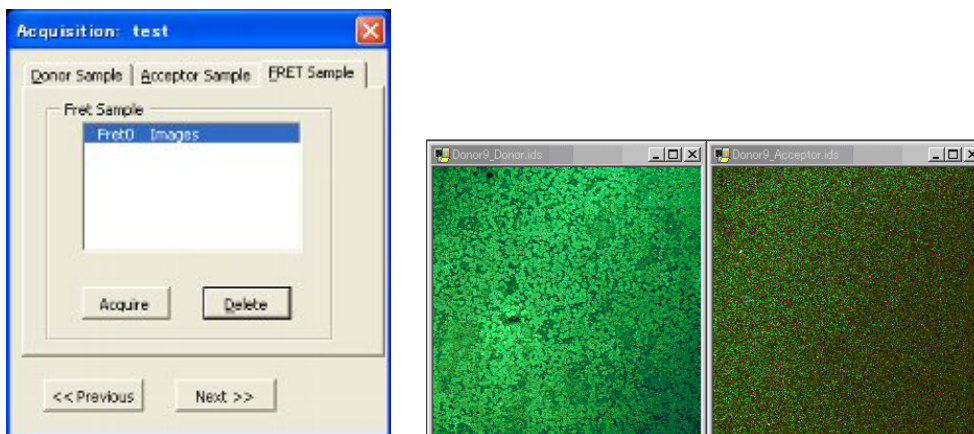

Note
 - When the [Next>>] button is pressed, go to Step 17. And calculate the FRET efficiency.

13 Analyze the FRET data

Analyze the FRET data.



14 Select the experiment

Select the experiment for the FRET efficiency. And then, press the [To Analysis] button.

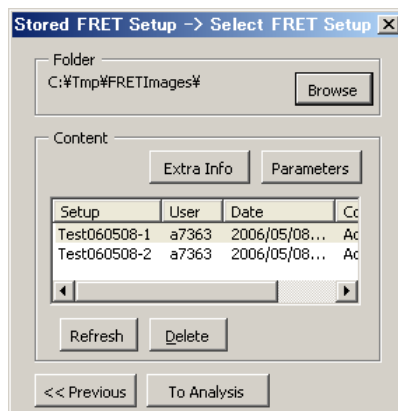

Note

Each button works as follows:

[Extra Info]: Edit the settings of the experiment.

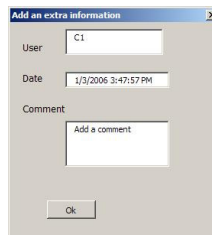

[Delete]: Delete the experiment settings.

[Parameters]: Verify the parameters used in the experiment.

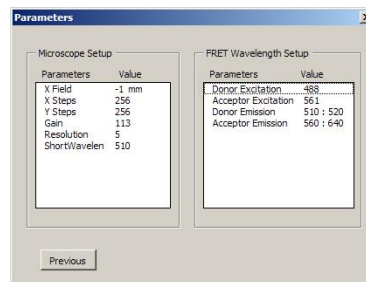

[Refresh]: Refresh the experiment names in the specified folder.

! To import FRET image data or settings of an experiment in other folder, copy the whole required folder to the specified folder. (Image data is saved to the folder specified in step 9 “Save the settings”.)

15 Select the “Donor” image

Select the “Donor” image used to calculate the FRET efficiency. Two or more images can be selected.

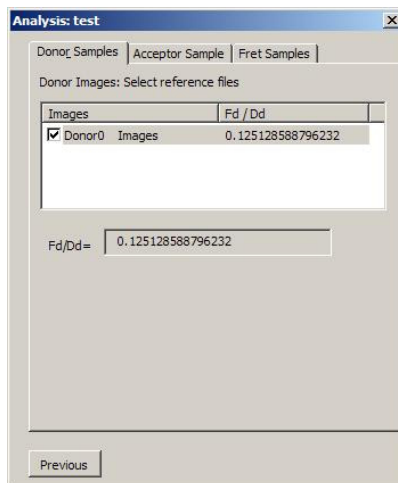

16 Select the “Acceptor” image

Select the “Acceptor” image used to calculate the FRET efficiency. Two or more images can be selected.

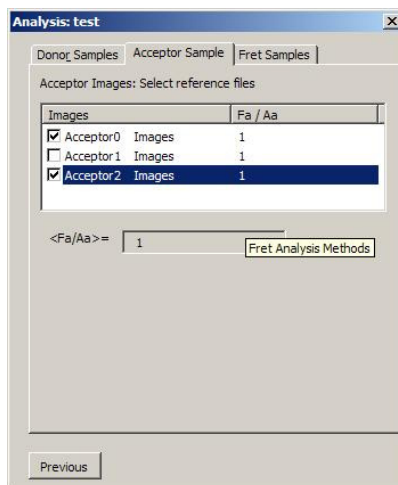

17 Calculate the FRET efficiency

Select the FRET image used to calculate the FRET efficiency. Two or more images can be selected. If necessary, change the “G” or “Thr” parameter. (For these parameters, refer to the following article.) To calculate the FRET efficiency, press the [Calculate] button. Three types of FRET efficiency are calculated. An image is created and each result is reflected to the channel data.

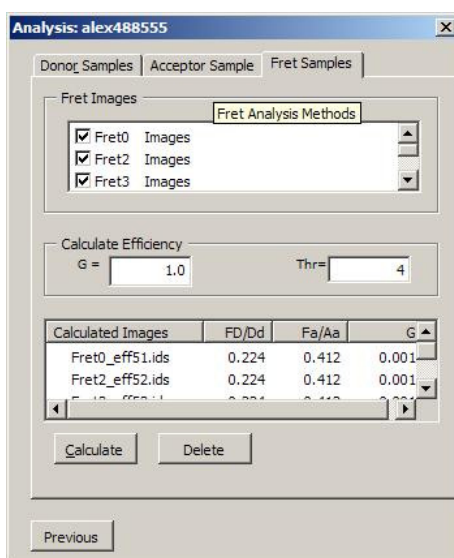

At last, the “Donor” image, the “Acceptor” image, the FRET image, and the calculation are displayed.

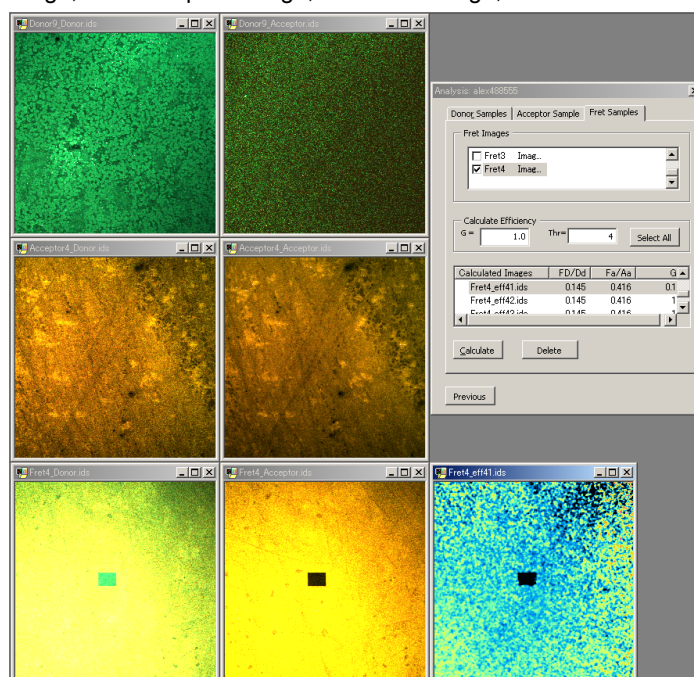

18 Display the FRET image

The result of the FRET efficiency calculation is output as three channel images. Each channel has a different result that was acquired with different calculation method.

Channel No.	Algorithm
1	Gordon algorithm
2	Youvan et al method
3	Xia et al calculation algorithm

Channel 1 is displayed in the default setting for the FRET efficiency calculation result. To display another channel, select the channel on the Color tab in the “View Settings” dialog box.

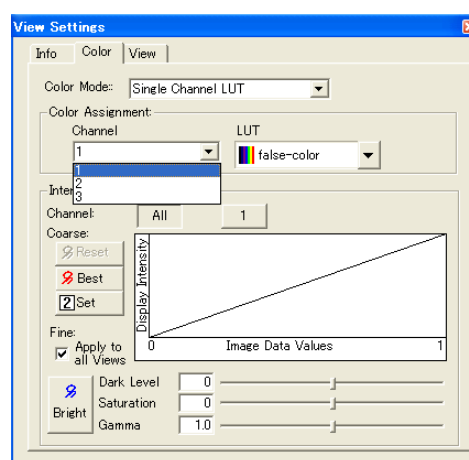
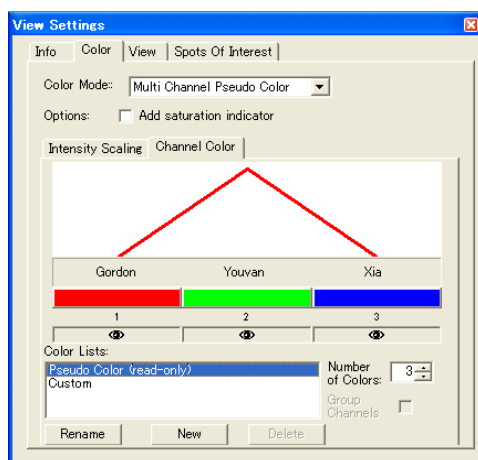

Parameters used in the FRET efficiency• **G:** System Constant G

The Gordon algorithm requires a system constant G. This constant determines the scaling of the FRET image. The actual value of the G constant depends on the spectral properties of the dyes, the ratio of the laser intensities and the ratio of the detector sensitivities and is best determined experimentally. Typical values are between 1 and 0.01. When samples have been measured with a known FRET efficiency, the G constant can be changed until the calculated FRET image shows the correct values.

• **Thr:** Threshold

The Threshold percentages indicate which darker fraction of the pixels is ignored during the calculations. Dark pixels feature a higher signal to noise level than brighter pixels and can result in a noisy result image. For the Reference image, a typical value for the threshold is 20 %. The best sample reference threshold depends on the intensity of the sample images and varies between 1 to 10 %. Increase this value if the FRET image has noisy areas.

Click on the Calculate button to start the calculations and an image is generated with FRET efficiency results. FRET efficiency will be calculated for files that are checked in FRET Sample images box. The name of generated FRET efficiency image contains the name of original FRET Sample files that has been used for efficiency calculation.

Naming rule of images

A new folder, FRETImages, is created in the folder where the FRET sequence macro is installed. Images are saved in this folder. Create an "experiment name" folder in the FRETImages folder and save images into it.

"Donor," "Acceptor," and FRET images are named and saved as follows:

Image	filename
Donor	Donor<X>_Donor.ids
	Donor<X>_Acceptor.ids
Acceptor	Acceptor<X>_Donor.ids
	Acceptor<X>_Acceptor.ids
Fret	Fret<X>_Donor.ids
	Fret<X>_Acceptor.ids

Here, <X> means a number created by the system. And the character string after the underscore (_), Donor or Acceptor, represents the laser type used to capture the image.

The result image of the FRET efficiency calculation is named and saved as follows:

Image	filename
Fret	Fret<X>_eff<Y>.ids

Here, Fret<X> means the FRET image and <Y> means a number created by the system.

To import a FRET image from other system

- Copy the whole folder that has the “experiment name” for its name under <FRET macro folder>/FRETImages/ of the old system to the same location of the new system. The FRET sequence macro searches the folder at the next start-up and detects the new imported data.

Reference:

- Gordon, G.W., Berry, G., Liang, X.H., Levine, B., Herman, B. Quantitative Fluorescence Resonance Energy Transfer Measurements Using Fluorescence Microscopy. Biophysical Journal 47: 2702-2713 (1998)
- M. Balzar Quantitative Measurements Of FRET Using Standard Confocal Fluorescence Microscopy (2006)

A.6 Colocalization Macro

Follow these steps for colocalization analysis.

1 Load the Colocalization macro

For loading the macro file, refer to the head description of “A Experiment Sequence Macro.”

Note

- The colocalization macro file is provided on the CD-ROM disc. This macro is installed together with the EZ-C1 application software if the application software is installed using the EZ-C1’s integrated installer (All EZ-C1 3.80 Project).
The file is installed in a folder named “Program Files\Nikon\Shared\Projects.”

2 Run the Colocalization macro

After selecting and activating the window of the image for colocalization analysis, choose Data > Analyze > Colocalize.

CAUTION

- The Colocalization macro can be used on data with two or more channels. (For example, standard data, spectral data, and unmix data.)
- Do not execute other macro applications when the Colocalization macro is running.

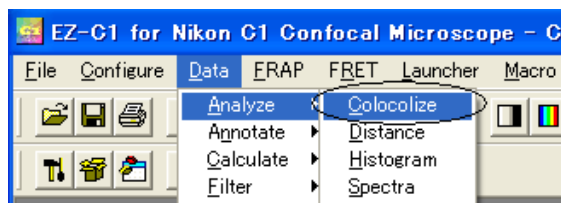

The Colocalization dialog box and Scatter Plot window are displayed.

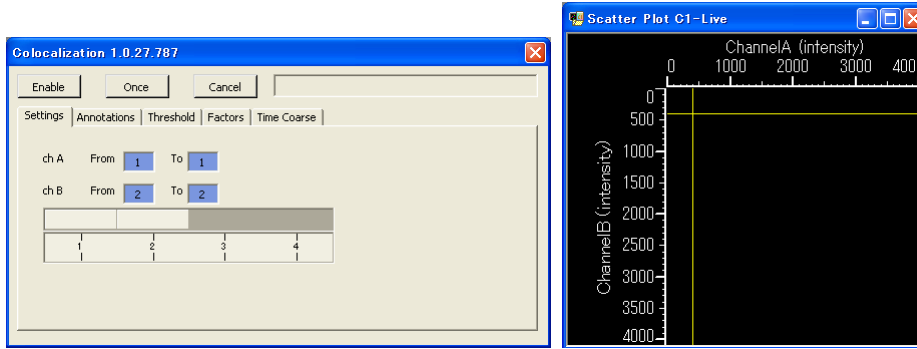

3 Display the spatial distribution of the colocalized data

3-1 Select two channels

On the Settings tab, select two channels of the image for colocalization analysis. To select, move both slider bars.

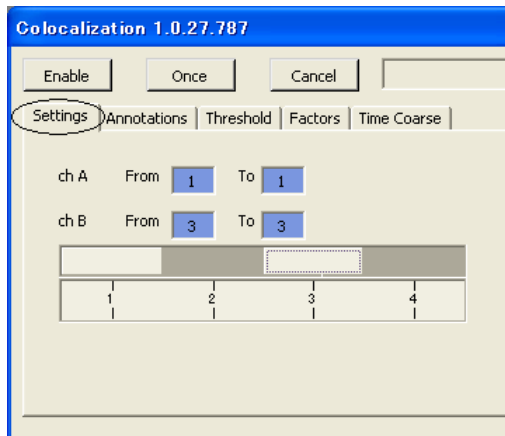

Note

A continuous channel region can be selected for the spectral data by expanding or shrinking the slider bar.

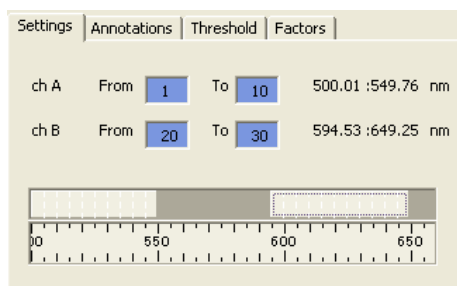

3-2 Display the Scatter Plot

In the Colocalization dialog box, click the [Once] or [Enable] button to plot the data for all pixels of the image in the Scatter Plot window. The intensity of both channels is plotted on the axes.

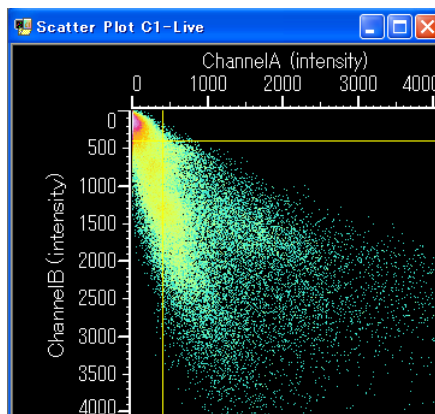
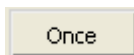

Note

- (a) If an image representing Z-stack data was selected, data for all slices is plotted in one Scatter Plot window.
- (b) If an image representing Time Series data was selected, data for each stack (for each T) is plotted.

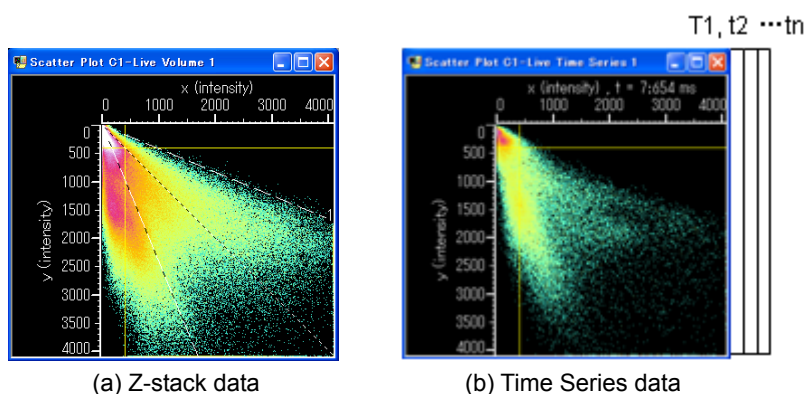

- [Enable] button: Target and simultaneously update the data currently being acquired.

3-3 Display the spatial distribution for the colocalized data

On the Annotations tab, specify a sector. In the Scatter Plot window, specify the colocalized region.

Clicking the [Add Sector] button displays the sector in the Scatter Plot window. Use the mouse to adjust the central angle and sector angle, as desired.

Selecting "Back Annotate Overlay" displays the colocalized data superimposed on the image. Plotted data in the sector (and over the threshold) is displayed as colocalized data.

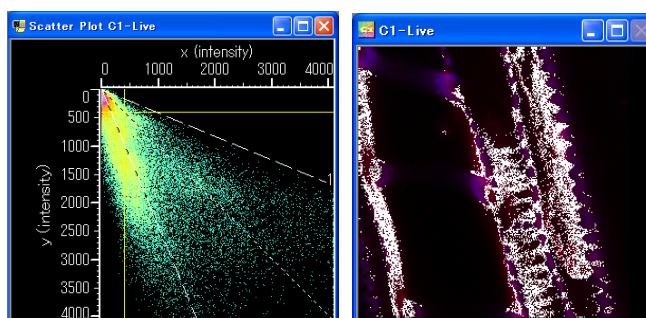
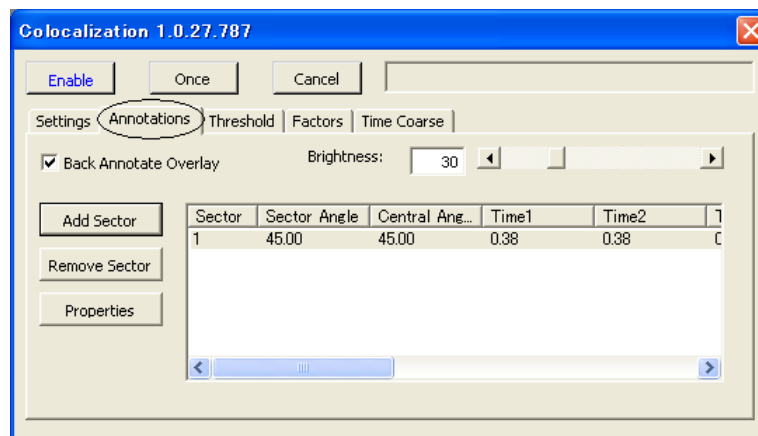

Note

- Back Annotate overlay: Overlays the colocalized data on the target image. Plot data within the sector (and over the threshold) will be displayed as the colocalized data.
- Brightness: Sets the density (%) for overlying the colocalized data.
- [Add Sector]: Displays a sector on the Scatter Plot window to specify the colocalized area. Use the mouse to adjust the central and acute angles.
- [Remove Sector]: Click to remove selected sectors in the list.
- [Properties]: Click to specify a color and label for selected sectors in the list. The distribution of colocalized data will be displayed in the same color as the sector.
- If an image representing Time Series data was selected, the proportion of pixels in each sector (and over the threshold) in each set of stack data is displayed on the Annotations tab. (Time N = number of pixels in the sector that are over the threshold / number of pixels over the threshold)

Time2	Time3	Time4	Time5	Time6	Time7
0.24	0.24	0.24	0.25	0.00	0.01

- Save: Images for which a spatial distribution of colocalized data is displayed can be saved as TIFF (bitmap) or bitmap format. The content of Scatter Plot windows can be saved in IDS or TIFF (RAW) format.

4 Obtain the colocalization factor

4-1 Specify the threshold

On the Threshold tab, specify the intensity threshold value for each channel. (The same threshold setting also applies to the spatial distribution of colocalized data.)

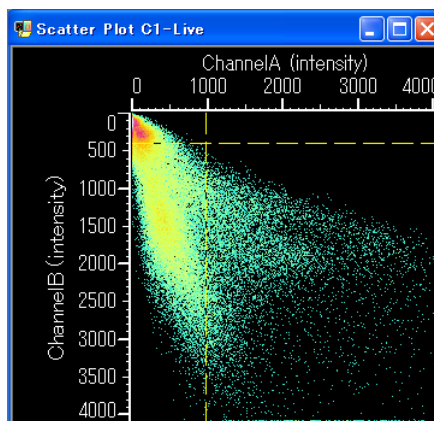
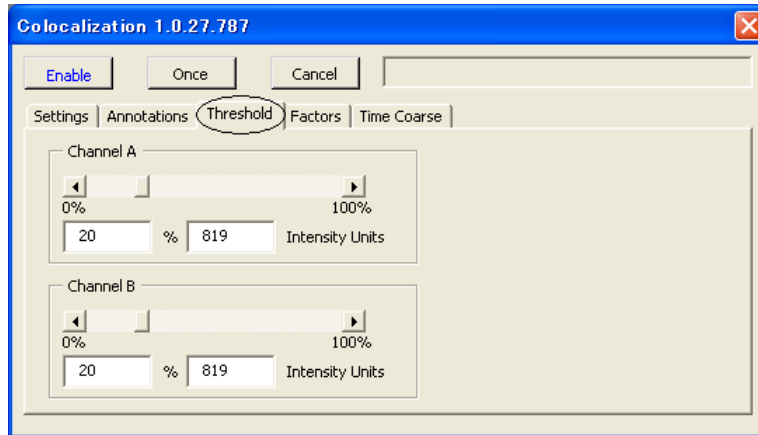

4-2 Obtain the factor

On the Factors tab, obtain the correlation coefficient for Pearson, Manders A, Manders B, and Manders's Overlap.

If desired, click the [Export Data] button to export this data as a text file.

The screenshot shows the 'Factors' tab in the 'Colocalization 1.0.27.787' window. The 'Export Data' button is highlighted. Below it is a table with the following data:

Time	Pearson	MandersH(A)	MandersH(B)	Overlap	MandersA	MandersB
1	0.506	0.678	0.541	0.606	1.000	1.000
2	0.500	0.651	0.549	0.598	1.000	1.000
3	0.484	0.614	0.554	0.583	1.000	1.000
4	0.475	0.606	0.540	0.572	1.000	1.000
5	0.465	0.574	0.549	0.561	1.000	1.000
6	1.000	1.000	1.000	1.000	0.000	0.000
7	0.549	0.623	0.754	0.685	1.000	1.000
8	0.531	0.577	0.776	0.669	1.000	1.000
9	0.515	0.535	0.782	0.651	1.000	1.000

Note

- (a) If an image representing Z-stack data was selected, the calculation applies to all slice data at once.
- (b) If an image representing Time Series data was selected, the calculation applies to data for each stack (for each T). Trends during the time of each factor are also shown on the graph. (Red: Pearson; Green: Manders A; Blue: Manders B)

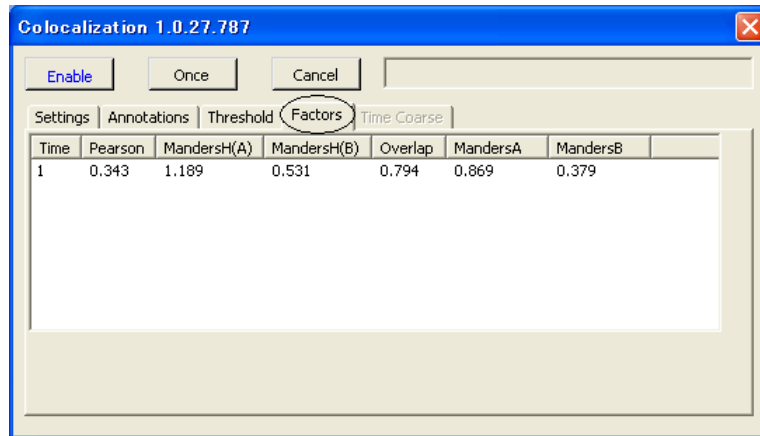

(a) Z-stack data

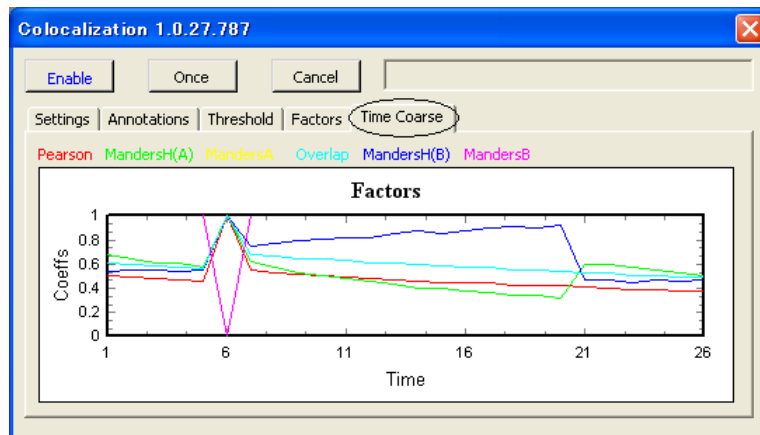
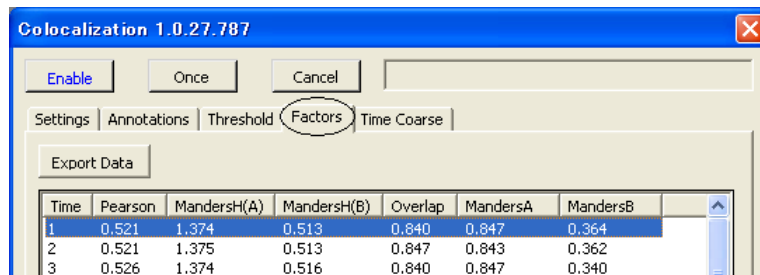

(b) Times Series data

A.7 AutoGain Macro

The AutoGain macro automatically adjusts gain so that brightness becomes optimum for observing images. The AutoGain macro is supported in the normal and spectral modes.

1 Load the AutoGain macro

For loading the macro file, refer to the head description of "A Experiment Sequence Macro."

Note

- The AutoGain macro file is provided on the CD-ROM disc. This macro is installed together with the EZ-C1 application software if the application software is installed using the EZ-C1's integrated installer (All EZ-C1 3.80 Project).
The file is installed in a folder named "Program Files\Nikon\Shared\Projects."

2 Start the AutoGain macro

Select [AutoGain] from the [Macro] menu.

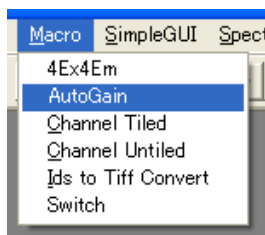

The AutoGain main frame appears.



Name	Function Overview
[Gain Optimization]	Press this button to adjust a gain of Detector Channel, which validates the update, to an optimum value. ! Laser Power When the shutter-opened laser power is set to "Min," the power is first adjusted to an appropriate value, and then gain adjustment is started.
[Settings]	The main frame is expanded and AutoGain setting items are displayed.
Status	Results of gain adjustment are displayed.

CAUTION

- The AutoGain macro adjusts gain with 2D(XY) scanning. Therefore, if sequence modes (Line Lambda, Average, Fr Lambda, Z-Stack, and Time) are set to ON when the AutoGain macro is started, all sequence modes automatically switches to Off. When the AutoGain macro is finished, settings of the sequence modes return to the settings when the macro was started.

3 AutoGain setting

After the [Settings] button is selected, a threshold value for completing gain adjustment processing can be set on the [Settings] tab of the acquisition setting. On the [Calibration] tab, gain calculation adjustment coefficient measurement is performed during gain adjustment and coefficients used for gain calculation are selected.

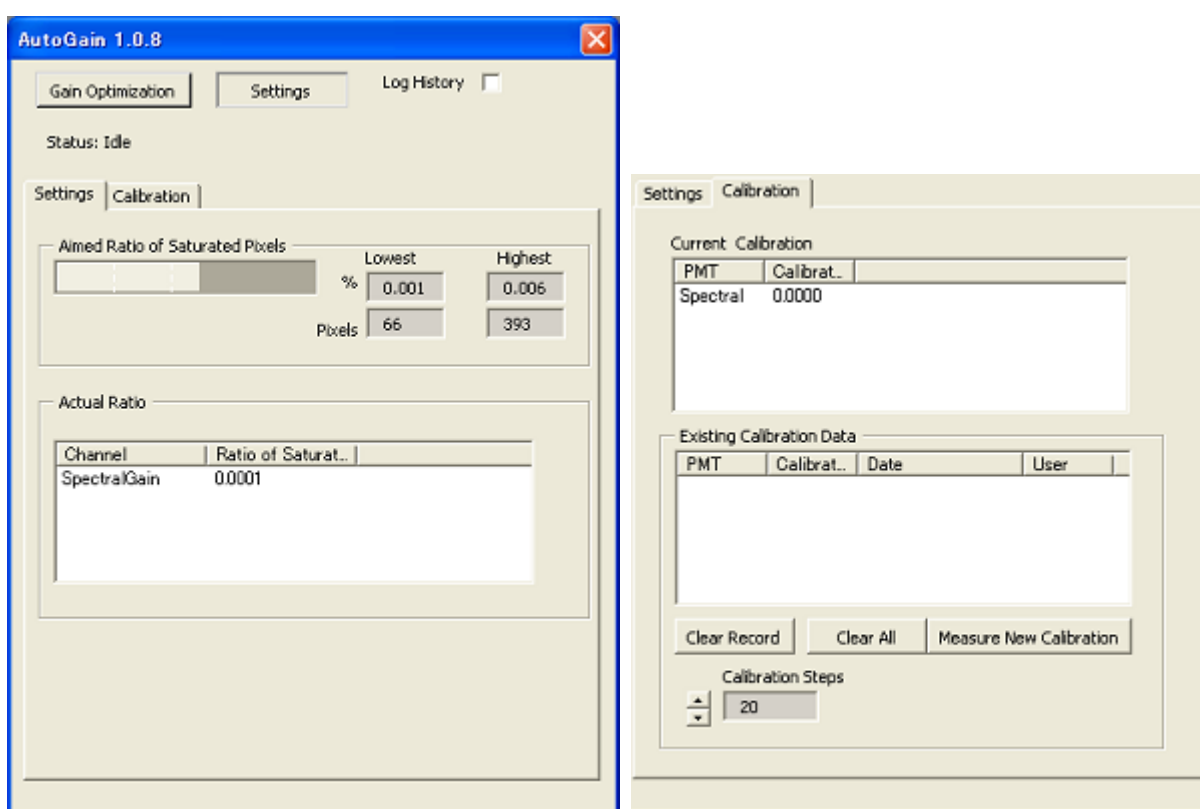

(1) Settings tab

Name	Function Overview
Aimed Ratio of Saturated Pixels	Target ratio of saturated pixels to the total pixels is set for adjusting gain. Gain adjustment is finished when the above setting is satisfied.
Actual Ratio List	The ratio of saturated pixels when gain adjustment is finished is displayed.

(2) Calibration tab

Name	Function Overview
Current Calibration List	Calibration data used for gain adjustment is displayed.
Existing Calibration Data List	<p>Measured calibration data is displayed. When the check box is checked, its data is used for gain adjustment.</p> <p>! Calibration data When check boxes of multiple calibration data are checked, the average value of checked data is used as calibration data.</p>
[Clear Record]	Data selected in the current calibration list is deleted.
[Clear All]	All data in the current calibration list is deleted.
[Measure New Calibration]	Calibration is performed.
Calibration Steps	A measurement data-acquisition count used for calibration measurement is set.

A.8 Live Unmix Macro

When this function is used, spectral data is obtained and simultaneously Unmixing calculation is performed in real time. And then the space distribution of each reagent data can be displayed.

Spectral data of each reagent used for Unmix calculation can be selected from "Reference data (Molecular probe, CLONTECH's data)" or "saved spectral data."

CAUTION

- This function is available only when spectral data is acquired in the Spectral mode.
- **An intended window of this function is always the C1 Spectral Live window.** The Unmix image is displayed in real time by updating an image in the C1 Spectral Live window.
- This function is **not supported in the special windows (Average, Volume, and TimeSeries)** in each observation mode.
- This function performs the same calculation as the [Unmix]>[Unmix] function of the Spectral menu. Note that High Accuracy Unmix calculation is not performed.

Use the following procedure to perform "Live Unmix":

1 Load the Live Unmix macro

For loading the macro file, refer to the head description of "A Experiment Sequence Macro."

Note

- The Live Unmix macro file is provided on the CD-ROM disc. This macro is installed together with the EZ-C1 application software if the application software is installed using the EZ-C1's integrated installer (All EZ-C1 3.80 Project).
The file is installed in a folder named "Program Files\Nikon\Shared\Projects."

2 Start the Live Unmix macro

Select [Live Unmix] from the Spectral menu.

CAUTION

- Live Unmix can be used only in the Spectral mode.
- While the Live Unmix macro is running, do not start any other macro application.



The Spectral Live Unmix dialog box appears.

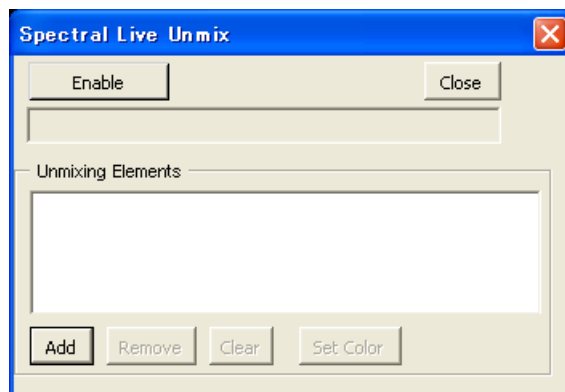

3 Reagent data setting

Set reagent data to be used for Unmix calculation. Select "Reference data (Molecular probe, CLONTECH's data" or "saved spectral data" using the [Add] button.

Specify the reagent data used for the acquired image.

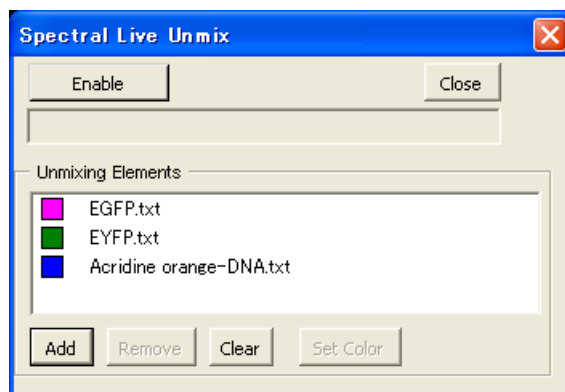

Note

- [Add]: Select reagent data to be used for Unmix calculation.
- [Remove]: One of the selected data of the reagent is deleted.
- [Clear]: All reagent data is deleted.
- [Set Color]: For data of each reagent, set a display color of a result image obtained from Unmix calculation. Default color can be changed.

4 Validate Live Unmix mode

To validate the Live Unmix mode, follow the procedure below. Press the [Enable] button to change a mode in which Unmix calculation is performed on images in the C1 Spectral Live window. The C1 Spectral Live Live Unmixed window appears to display calculation results.

Enable

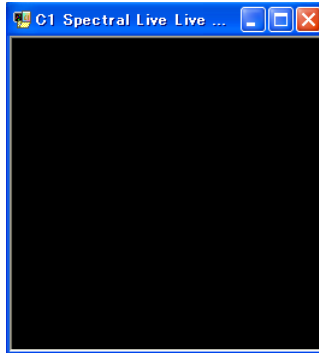

Note

- [Enable]: Data in the C1 Spectral Live window is calculated by Unmix calculation function.
- [Close]: The Spectral Live Unmix dialog box closes to end.

5 Run Live Unmix

Press the [Live] or [Single] button in the Acquire Setting dialog box so that images are acquired into the C1 Spectral Live window. At the same time, images of Unmix calculation results are displayed in real time in the C1 Spectral Live Live Unmixed window.



<Acquired data in the C1 Spectral Live window>



<Unmix calculation result>

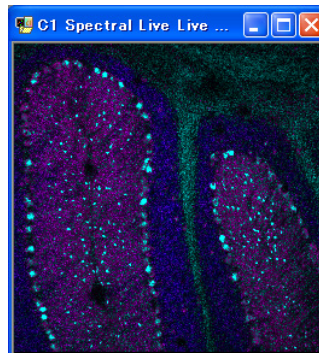

Note

- [Enable]: Perform Unmix calculation of data in the C1 Spectral Live window.
- [Close]: The Spectral Live Unmix dialog box closes to end.

6 End Live Unmix

Press the [Close] button to end the Spectral Live Unmix macro.



A.9 Z-stack Intensity Control Macro

This function allows you to observe Z-stack while changing the laser power. Setting the laser power beforehand for multiple slices to observe a thick sample enables Z-stack observation with the laser power suited for the depth of each slice. Blight data can be acquired even at a slice far from the objective. In addition, this function allows you to save the setting conditions and reuse them.

Execute the Z-stack Intensity Control macro using the following procedure.

1 Load the Z-stack Intensity Control macro

For loading the macro file, refer to the head description of “A Experiment Sequence Macro.”

Note

- Z-stack Intensity Control macro file is provided on the CD-ROM disc. These macro files are installed together with the EZ-C1 application software if the application software is installed using the EZ-C1's integrated installer (All EZ-C1 3.80 Project).
The file is installed in a folder named Program Files\Nikon\Shared\Projects.

2 Run the Z-stack Intensity Control macro

Choose “Z Intensity Control” in the macro menu.

CAUTION

- Do not execute other macro applications when the Z-stack Intensity Control macro is running.



“Z Intensity Control” dialog box opens.

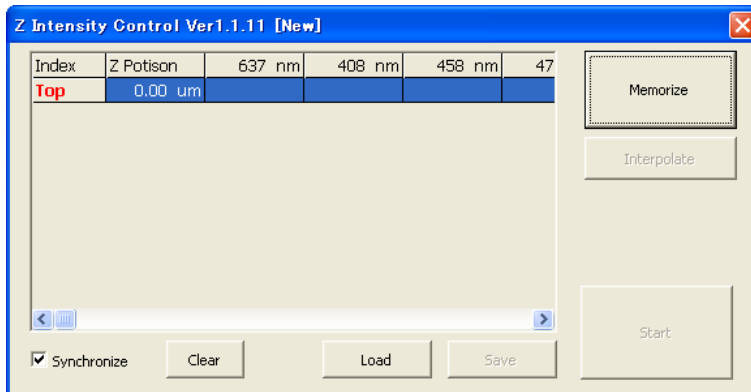

3 Set the top position

Select the “Top” checkbox in the Z-Stack tab of the EZ-C1, and control the Z stage to determine the top position in the Z-stack mode. Then the Z position of the top position is reflected in the macro.

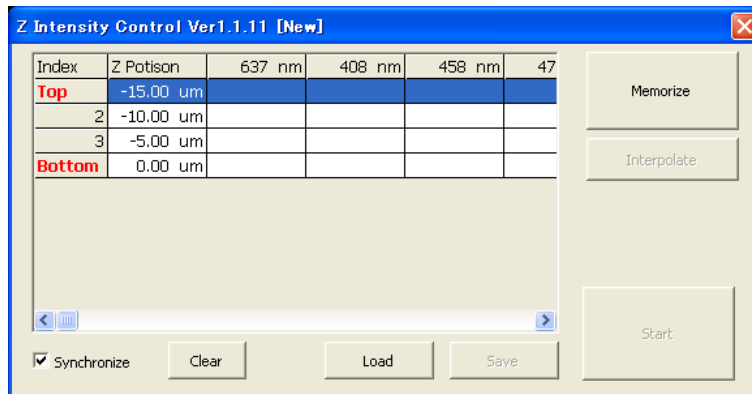
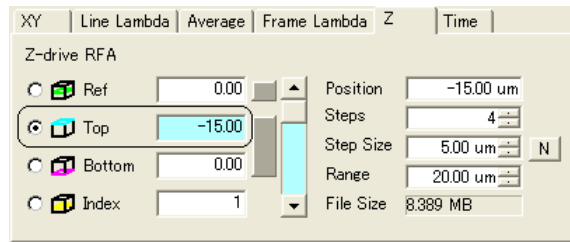

4 Set laser power for the top position

Adjust the laser power in the Laser Control Bar dialog box concurrently with live observation with the Z position set to “Top.” Set proper laser power and press the [Memorize] button of the macro. Then the laser power is reflected in each “Laser” column of the Top position.

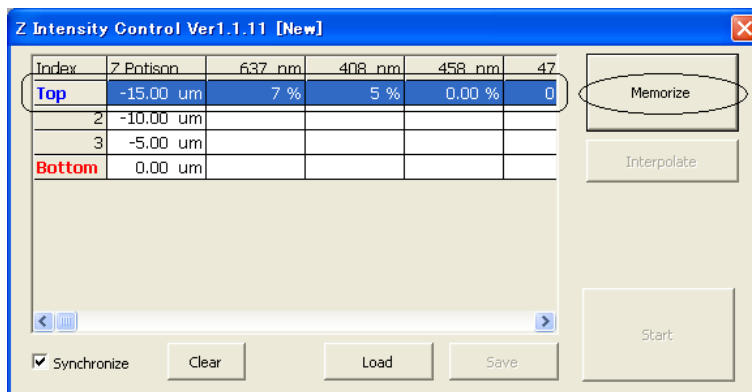
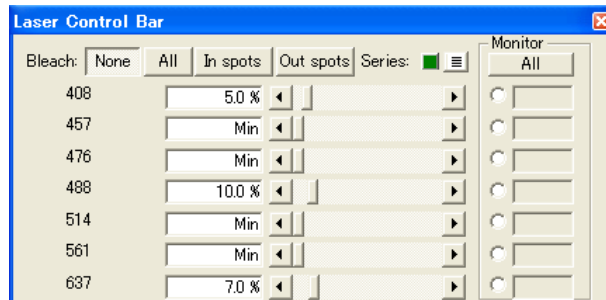

5 Set the bottom position

Select the “Bottom” checkbox in the Z-Stack tab of the EZ-C1, and control the Z stage to determine the bottom position in the Z-stack mode. Then the bottom position and the Z position at each slice position that is set at intervals of Steps are reflected in the macro.

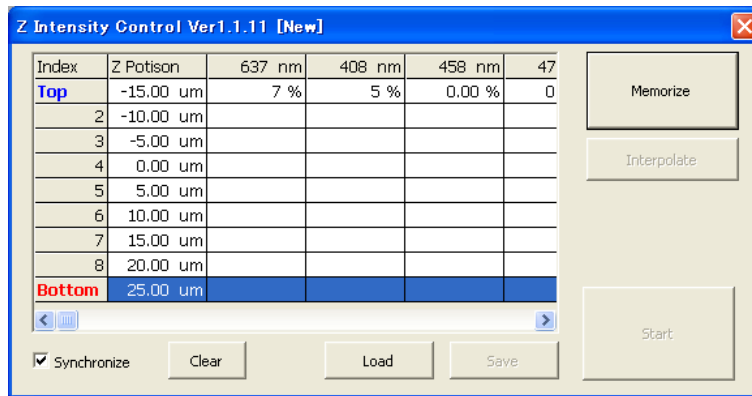
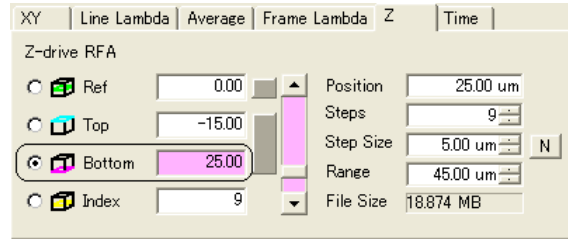

6 Set laser power for the bottom position

Adjust the laser power in the Laser Control Bar dialog box concurrently with live observation with the Z position set to “Bottom.” Set proper laser power and press the [Memorize] button of the macro. Then the laser power is reflected in each “Laser” column of the Bottom position.

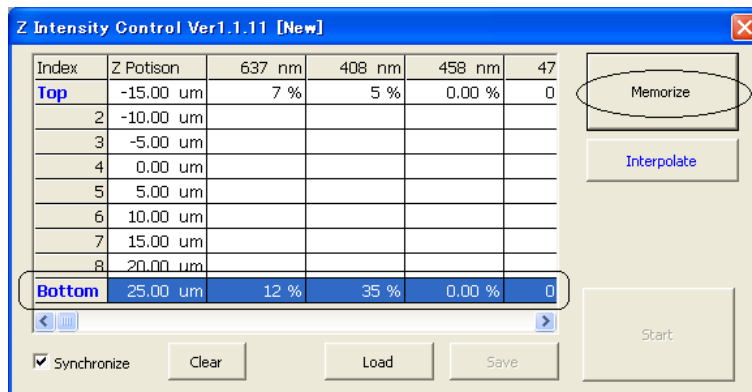
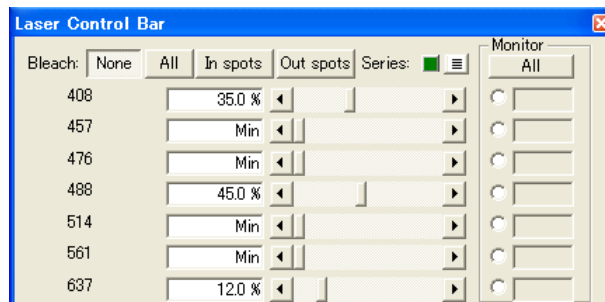

7 Set laser power for arbitrary Z positions

Select the “Synchronize” checkbox in the macro and then click the “Index” column to control the Z stage to determine arbitrary Z positions in the Z-stack mode. (The Z stage can also be controlled by selecting the “Synchronize” checkbox and clicking the “Index” column.)

Adjust the laser power in the Laser Control Bar dialog box concurrently with live observation at the selected Z positions. Set proper laser power and press the [Memorize] button of the macro. Then the laser power is reflected in each “Laser” column of the selected Z positions.

Set two or more arbitrary Z positions.

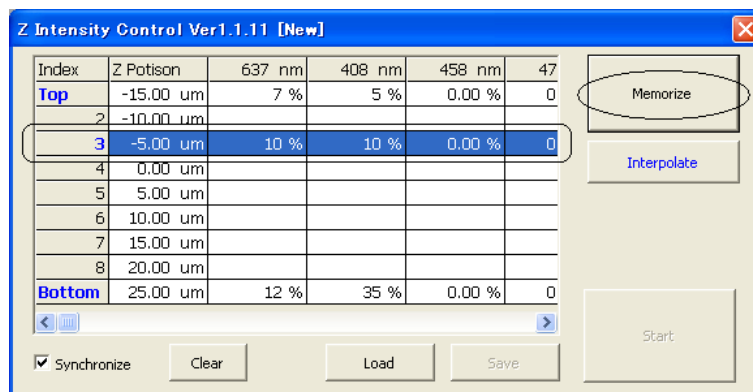
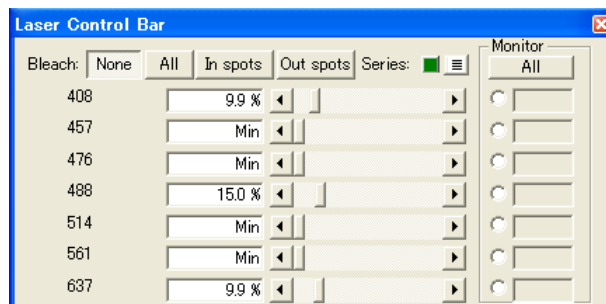
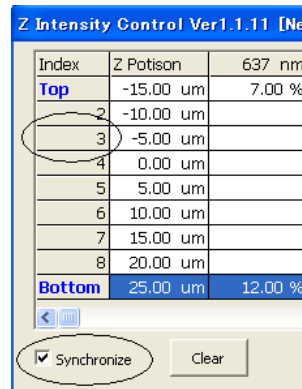

CAUTION

- Set “two or more” arbitrary Z positions.

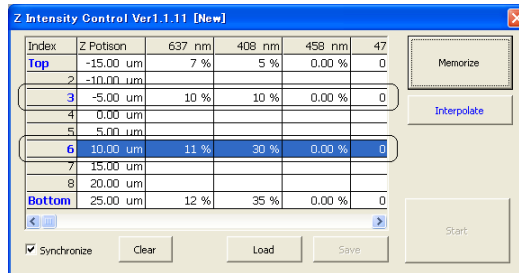

- To select an arbitrary Z position, click the Index column in the macro window. Do not use the “Synchronize” checkbox in the Z-stack tab of EZ-C1.

8 Interpolation calculation

Press the [Interpolate] button to calculate curve interpolation using the set laser poser at Z positions. As a result, the laser power of all unset Z positions is set.

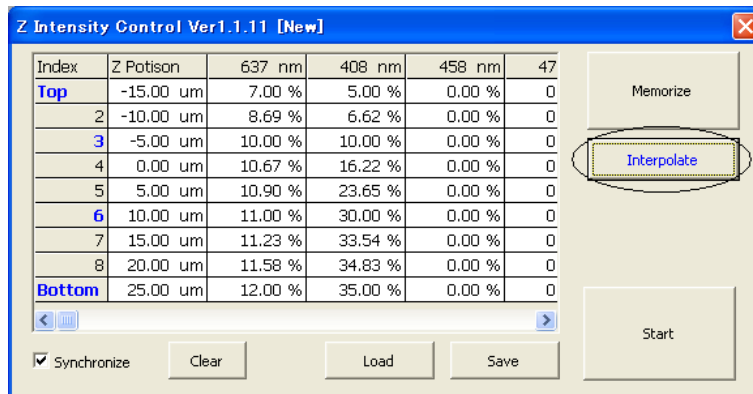

9 Start Z-stack observation

Press the [Start] button to perform Z-stack observation while changing the laser power according to the setting. The Volume window for Z-stack data opens with the captured image.

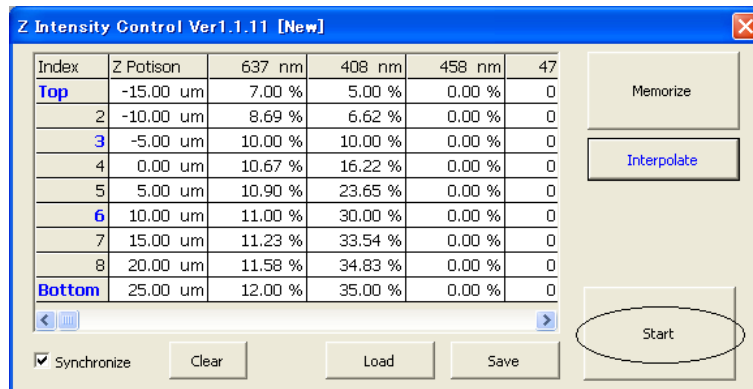

CAUTION

- The Intensity Control setting of the set Z-stack can be saved and reused.
[Save]: Saves the current settings in a file with extension .zpm.
[Load]: Re-sets the saved settings. All settings including the Z-stack setting and the laser power setting of each Z position are restored.
- All settings can be completely cleared.
[Clear]: Clears the current settings completely.

Note

- Z-stack observation can be used together with other observation modes.
Set an observation, e.g. Average, Frame Lambda Series, and Time Series using the Acquire Settings dialog box. Then press the [Start] button on the macro to start Z-stack interlocking with the modes.

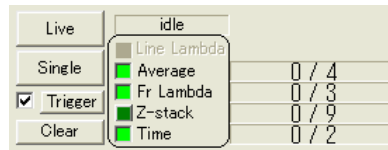

- When Z-stack observation is started using macro, the “Trigger” checkbox is set to ON by default.
When the macro stops, it is set to OFF automatically.

A.10 Tiff Series Export Macro

This function allows to serially save all channel data as Tiff data with the “1-Channel 8-Bit or 1-Channel 16-Bit” format by batch processing. For 3D and 4D data, they can be serially saved as Tiff data with the “Bitmap” format by batch processing.

Use the following procedure to perform “Tiff Series Export”:

1 Load the Tiff Series Export macro

For loading the macro file, refer to the head description of “A Experiment Sequence Macro.”

Note

- The Tiff Series Export macro file is provided on the CD-ROM disc. This macro is installed together with the EZ-C1 application software if the application software is installed using the EZ-C1’s integrated installer (All EZ-C1 3.80 Project).
The file is installed in a folder named Program Files\Nikon\Shared\Projects.

2 Start the Tiff Series Export macro

Make a window, in which the target images to be serially saved with a Tiff format exist, active and then select [Tiff Series Export] from the Macro menu.

CAUTION

- The target images can also be changed after the Tiff Series Export macro is started.
- While the Tiff Series Export macro is running, do not start any other macro application.

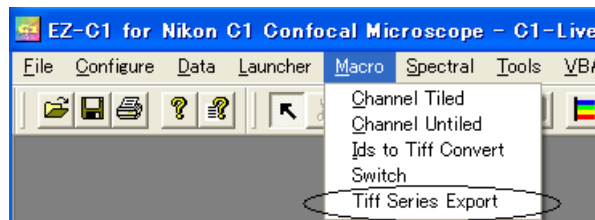

The Tiff Series Export dialog box appears.

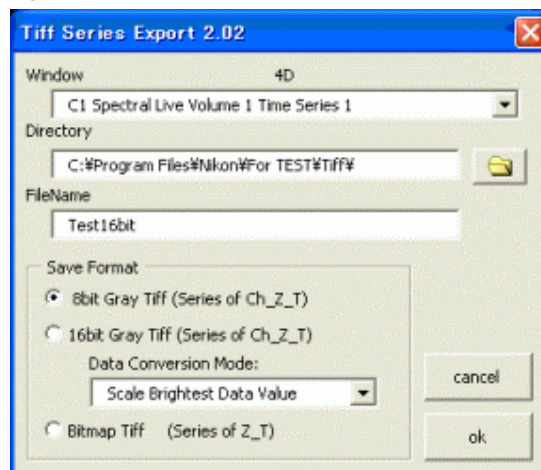

3 Confirm target images

Confirm the target images to be serially saved. Other window which is currently opened can be selected from the pull-down menu.

When the target images are 3D or 4D, all data is saved by batch processing.

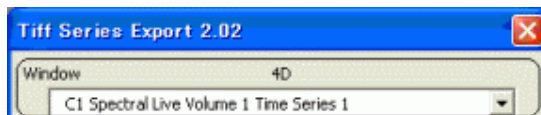

4 Specify a saving destination and a file name

To serially save images, set a save destination and file name.



5 Set the Tiff format

To serially save images, set a Tiff format.

Select an appropriate format from "8bit Gray Tiff," "16bit Gray Tiff," and "Bitmap Tiff."

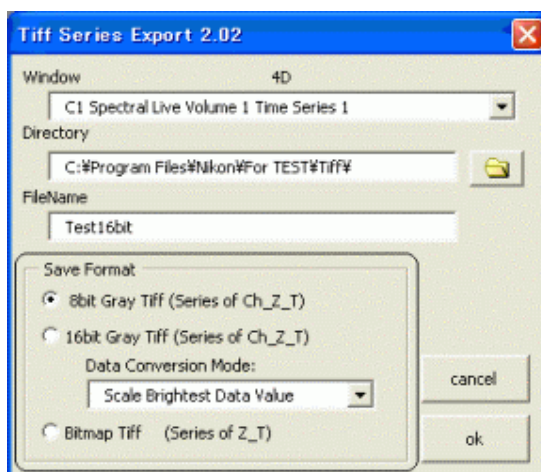

Note

- 8bit Gray Tiff: Save all channel data in the 8 bit Gray Tiff format. When the target images are 3D or 4D, they are saved serially in the order of z, t, and ch.
- 16bit Gray Tiff: Save all channel data in the 16 bit Gray Tiff format. When the target images are 3D or 4D, they are saved serially in the order of z, t, and ch.
- Data Conversion Mode: Set the method for converting data into 8-bit data or 16-bit data.
 - Scale Brightest Data Value: Data is adjusted based on the brightest data so that the dynamic range fits in 8-bit or 16-bit.
 - Scale Full Range: By truncating (adding) lower four bits of (to) 12-bit data, the 12-bit data is converted to the 8 bit (16-bit) data.
- Bitmap Tiff: Save all slice data in Bitmap format. They are saved serially in the order of z and t.

6 Serially Saving

Press the [OK] button to serially save images with a Tiff format.

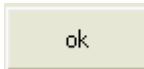

Note

- When the "8bit Gray Tiff" or "16bit Gray Tiff" format is used, each dimensional data is expressed in the format of "file name_chN_tN_zN.tif."

Examples of saved data:

XXX_ch1_t1_z1.tif
XXX_ch1_t1_z2.tif
XXX_ch1_t1_z3.tif
XXX_ch1_t2_z1.tif
XXX_ch1_t2_z2.tif
XXX_ch1_t2_z3.tif
XXX_ch2_t1_z1.tif
XXX_ch2_t1_z2.tif
XXX_ch2_t1_z3.tif

- When the "Bitmap Tiff" format is used, each dimensional data is expressed in the format of "file name_tN_zN.tif."

Examples of saved data:

XXX_t1_z1.tif
XXX_t1_z2.tif
XXX_t2_z1.tif
XXX_t2_z2.tif

A.11 SimpleGUI Macro

SimpleGUI is an application for easy image acquisition using C1 or C1si systems. This application is used to observe images of specimens obtained using the 1 excitation 1 emission ratio sequence macro, and consists of functions necessary for image acquisition and minimum setting items.

The application supports the following functions in a GUI, integrating each in a series of steps:

- Optical path setting → field of view setting → brightness setting → image acquisition setting → image acquisition

Compatible hardware is as follows.

- Ti-E microscope
- TE2000-E microscope
- I-Series microscope
- Z-drive RFA
- Prior ProScan II XY Stage without Z-Drive
- Perfect Focus System

CAUTION

This section solely describes how to start the program. [For details on SimpleGUI functions, see the Help file in the SimpleGUI program.](#)

1 Operate environment

Use the following version of EZ-C1 when using SimpleGUI.

- EZ-C1: Ver. 3.80 or later

Note

- Complete the required hardware-related settings beforehand in the Configure menu of EZ-C1.

2 Load Simple GUI macro

For loading the macro file, refer to the head description of "A Experiment Sequence Macro."

Note

- The Simple GUI macro file is provided on the CD-ROM disc. This macro is installed together with the EZ-C1 application software if the application software is installed using the EZ-C1's integrated installer (All EZ-C1 3.80 Project).
The file is installed in a folder named Program Files\Nikon\Shared\Projects.

3 Run the SimpleGUI macro

In the [SimpleGUI] menu of EZ-C1, select [SimpleGUI].

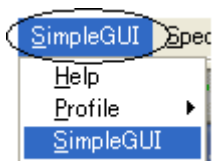

After you start the SimpleGUI macro, the following screen is displayed.

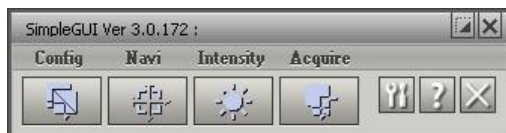

For details on SimpleGUI functions, see the Help command in the [SimpleGUI] menu.

4 End the SimpleGUI macro

To end SimpleGUI, click the [Close] button in the Main dialog box of SimpleGUI.

A.12 Thumbnailer

Thumbnailer is a standalone application that can be used independently of EZ-C1 or EZ-C1 Viewer. The application supports the following functions.

- Thumbnail list: Displays image data acquired by EZ-C1 as thumbnails.
- Detailed information: Displays details of image files in IDS format.
- Reuse functions: Applies hardware settings at the time of image data acquisition of selected files for reuse by EZ-C1.

CAUTION

This section solely describes how to start the program. [For details on Thumbnailer functions, see the Help file in the Thumbnailer program.](#)

1 Operate environment

Use the following version of EZ-C1 or EZ-C1 Viewer when using Thumbnailer.

- EZ-C1: Ver. 3.80 or later
- EZ-C1 Viewer: Ver. 3.80 or later

2 Load the Thumbnailer launch macro

For loading the macro file, refer to the head description of “A Experiment Sequence Macro.”

Note

- The Thumbnailer software is provided on the CD-ROM disc. The Thumbnailer launch macro is installed together with the EZ-C1 application software if the application software is installed using the EZ-C1's integrated installer (All EZ-C1 3.80 Project).
The file is installed in a folder named Program Files\Nikon\Shared\Projects.

The [Thumbnailer] button is added to the EZ-C1 toolbar buttons.



3 Start Thumbnailer

To start Thumbnailer from EZ-C1, click the [Thumbnailer] button in EZ-C1. To start Thumbnailer as a stand-alone application, click the Windows [Start] button and select Programs > Nikon > EZ-C1 Thumbnailer, or double-click the EZ-C1 Thumbnailer icon on the desktop.

The following dialog box is displayed.

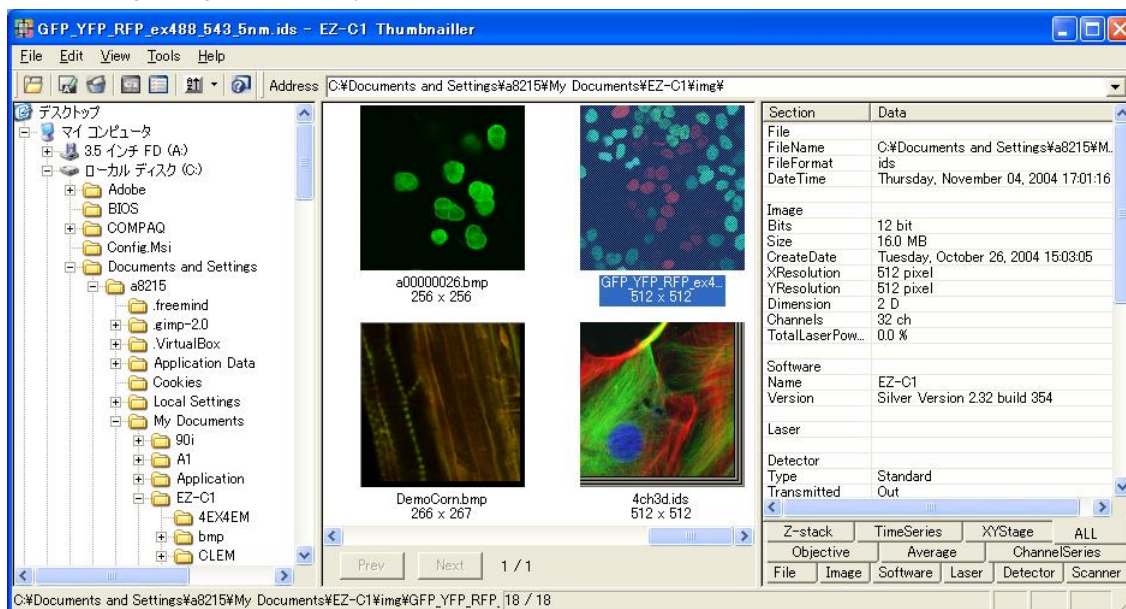

For details on Thumbnailer functions, see the Help file in the Thumbnailer program.

4 End Thumbnailer

To end Thumbnailer, select File > Exit in the Thumbnailer program.

B

Data File Formats

The supported file formats include:

- *.ics/*.ids: Image Cytometric Data File Format (see B.1)
- *.tiff/*.tif: Adobe Tagged Image File Format (see B.2)
- *.avi: Audio Video Interleaved Format (see B.3)
- *.bmp: Windows Bitmap (see B.4)
- *.xls: Excel Worksheet (see B.5)
- *.txt: Ascii Text Format (see B.6)

B.1 Image Cytometric Structure

The ics format was presented by Ph. Dean et al. in Cytometric 11:561-569 (1990). An ics image is stored in two files. One file is written in ASCII to include information about the format of the image data and optionally, information about the sample, experiment, equipment etc. The extension of the ASCII file is ics. The image data are written separately into a binary file. The extension of the binary file is ids. EZ-C1 uses the ics format as the default image format. All data types used in EZ-C1 can be stored in the ics format without loss of information.

B.2 Adobe Tagged Image File Format

The Tagged Image File Format –known as TIFF– was developed by Aldus which has now merged with Adobe Systems. The Tiff format is a versatile format that can handle all bitmapped images. Few programs are able to read all supported formats. However, most programs do support the 24-bits RGB format. For the highest level of compatibility, check the RGB format on the “Options” of “Save As” dialog box (see 4.1.5.2).

B.3 Audio Video Interleaved Format

The Microsoft Audio Video Interleaved Format (avi) is capable of storing a sequence of bitmap images that can be played with the Microsoft Media Player at a present frame rate. To store a 3D image in the avi format, select the *.avi format in the Save As dialog box and press the [Options...] button to specify the frame rate (see 4.1.5.3). The avi format stores images up to 3 channels and 8-bits accuracy without loss of information. However, the image descriptions tags (see 4.1.9) are not stored.

B.4 Windows Bitmap File Format

The Microsoft Bitmap Format (bmp) can be used to save the image as it appears on the screen. The format of the image equals the characteristics of the active window.

B.5 Excel Worksheet

Excel Worksheet is a spreadsheet format used by Microsoft Excel. Some restrictions apply with this format: it is only possible to secure data for up to 255 columns. For this reason, images obtained by the EZ-C1 which have data larger than 255 pixels cannot be saved in this format. Use this format when saving graphs obtained for a particular position.

B.6 Ascii Text Format

The Ascii Text Format can be use to edit plain dos text files. This file format is used for the report files. In addition, the integrated text editor can be used to view and edit the .ics files that describe the ics image format.

C

Troubleshooting

The EZ-C1 does not start.

[Cause] The program file is corrupted.

Following instructions in this manual, re-install the EZ-C1 and configure the software.

The image does not appear.

[Cause 1] Not connected to the network.

A. Check whether the system is connected to the network.

Follow the procedure described below to check whether the system is connected to the network.

1. Select “Start” → “Programs” → “Accessories” and then execute “Command Prompt”.
2. Execute the following command from the command prompt.

```
Ping 192.168.255.254
```

If results such as shown in the Figure C-1 are displayed, the system is connected to the network. If the system is connected to the network, go to [Cause2]. If the system is not connected to the network, continue beginning with Solution B to re-connect.

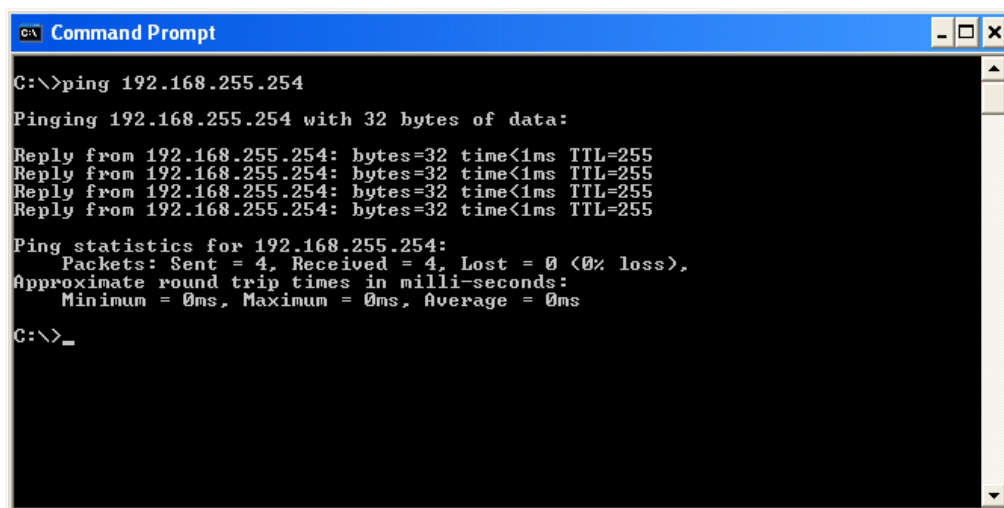

```
C:\> Command Prompt
C:\>ping 192.168.255.254
Pinging 192.168.255.254 with 32 bytes of data:
Reply from 192.168.255.254: bytes=32 time<1ms TTL=255
Reply from 192.168.255.254: bytes=32 time<1ms TTL=255
Reply from 192.168.255.254: bytes=32 time<1ms TTL=255
Reply from 192.168.255.254: bytes=32 time<1ms TTL=255
Ping statistics for 192.168.255.254:
    Packets: Sent = 4, Received = 4, Lost = 0 (0% loss),
    Approximate round trip times in milli-seconds:
        Minimum = 0ms, Maximum = 0ms, Average = 0ms
C:\>_
```

Figure C-1 Result of Ping command

- B.** Check that the “ready” lamp on the controller is lit.
Check that the Power lamp is lit. The controller is not turned on if the Power lamp is not lit. Check the condition of the power cord connection and the Power switch.
- C.** Check whether the network card is functioning.
Some network card may have a lamp on the board that flashes during communications. Look at the board through the rear of the PC and check if this lamp is flashing. If you can confirm that the lamp is flashing, go to Solution F. If you cannot confirm that it is flashing, go to Solution D.
- D.** Check that the network card driver is correctly installed.
Use the following procedure to check whether the network card driver is correctly installed.
1. Select “Start” → “Settings” → “Control Panel”.
 2. Double click “System” on the “Control Panel”, and display the “Hardware” tab on the dialog box that opens.
 3. Click the [Device Manager] button in the middle of the “Hardware” tab.
 4. Double click “Network adaptor” on the dialog box which appears as a result of Step 3, and check whether the network card driver is installed.
- The driver has not been installed properly if no driver for the network adaptor is listed on the “Device Manager” dialog box or if it is listed, but a question mark appears next to it. Please re-install the driver for the network.
- E.** Check whether the LAN cable is securely connected.
Check that the LAN cable is securely connected to the connectors on the computer and the C1 controller.
If the cable is securely connected, use a different cable and check again if the system is connected to the network following the instructions in Solution A.
- F.** Check the IP addresses of the computer and the controller.
Check the IP addresses of the computer and the controller based on information given in Chapter 1 of this manual.

[Cause 2] Problem due to over-gain of the photo multiplier.

Check whether the reset button on the Gain bar is flashing red.
If the reset button is flashing red, too much gain is being applied to the illumination level. If too much gain is being applied to the illumination level, the gain is cut-off to protect the Photo Multiplier, and the reset button flashes red. Press the reset button to reset the gain value to “0”, and set a new value for the gain.

[Cause 3] The laser box switch is not turned on.

Check the power and switch setting of the laser box.

[Cause 4] The pinhole is not stopping in the correct location.

It is possible that the pinhole is not stopping in the correct location.
You can hear a catching sound when the pinhole stops in the correct location as the protrusion on the pinhole catches on the stopper. If you cannot hear this sound, adjust the movement of the pinhole according to the following procedure.

1. Open the “Pinhole” tab.
2. Set the “Break Delay” mode to “manual setting”.
3. Change the “Break Delay” value.
4. Change the size of the pinhole using the “Laser and Detector” tool bar.
5. Check that the catching sound occurs and that the pinhole stops in the correct location.

[Cause 5] The channel is turned OFF.

Check whether the channel is turned off.

Use Channel in the Standard Detector tab in the Configure Confocal C1 dialog box or the Channel settings in the Color tab in the View Settings dialog box to check.

The image is rough.

[Cause] The illumination is not enough.

Use application settings to increase the gain.

Focus the image.

The illumination may drop drastically if the image is out of focus.