

**FINAL REPORT
TO THE
FLORIDA SPACE RESEARCH & EDUCATION
GRANT PROGRAM (FSREGP)**

*Development of a Gas Electron Multiplier (GEM) as a Novel Instrument
for X-ray Imaging Missions in Space*

Contract # UCF01-0000081024

Dr. Marcus Hohlmann, P.I.
Dept. of Physics & Space Sciences, Florida Institute of Technology,
Melbourne, Florida

August 23, 2007

1. Overview
2. Work performed
 - 2.1 Construction of a Triple-GEM Prototype Detector
 - 2.1.1 GEM stack
 - 2.1.2 Gas box and gas supply system
 - 2.1.3 High voltage circuit board
 - 2.1.4 Leakage current monitor
 - 2.2 Detector Testing and Commissioning
 - 2.2.1 Measurements of leakage currents
 - 2.2.2 Search for a detector signal
3. Technical Conclusion and Outlook
4. Educational Impact
5. Follow-up Funding
6. Related Reports and Presentations

1. Overview

This report describes work performed by the Florida Tech High Energy Physics Group under FSREGP Contract # UCF01-0000081024. This grant has been supporting the research activities of Dr. Marcus Hohlmann (faculty P.I.), graduate student Szabolcs Rembeczki, and undergraduate students, Rob Damadeo, David Dickey, Travis Garlick, Nick Leioatts, Jessi Lynn Mikkelson, and Julian Spring. Funding arrived at Florida Tech in two installments with a first portion of \$5,000 arriving on 11/10/05 and the balance of \$16,000 on 2/13/06. During summer 2006, the grant covered summer stipends for physics undergraduates Julian Spring and David Dickey. In the summer of 2007, physics undergraduate Nick Leioatts was supported with a partial summer stipend from the grant. Equipment and material purchases needed for the project were also funded from the grant.

2. Work performed

2.1 Construction of a Triple-GEM Prototype Detector

2.1.1 GEM stack

During the project period a triple-GEM detector using $10\text{cm} \times 10\text{cm}$ GEM foils was constructed. The first set of GEM foils for this detector was donated by colleagues from the Physics Department at Brookhaven National Lab, Upton, NY. Students designed and manufactured mounting frames for the GEM foils from G10 material in the Fl. Tech machine shop. The GEM foils were stretched, sandwiched between two frames, and fixed onto the frames using Stycast epoxy glue (Fig.1a). Three such subassemblies were stacked on top of a printed circuit board whose copper plane provided an induction plane for signal pickup (Fig.1b). A stainless steel mesh was also framed with G10 and placed on top of the GEM foil stack to provide a drift cathode completing the triple-GEM.

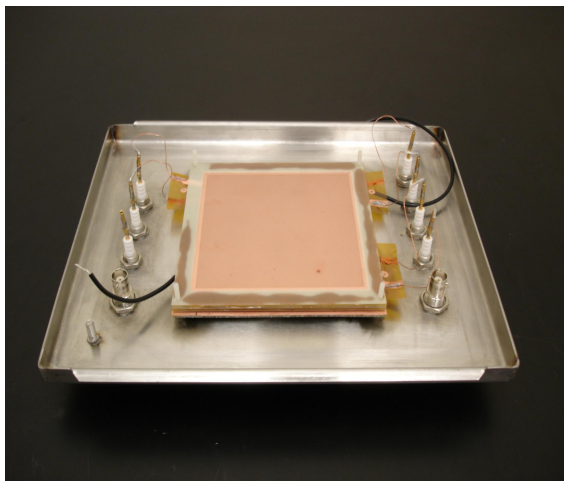
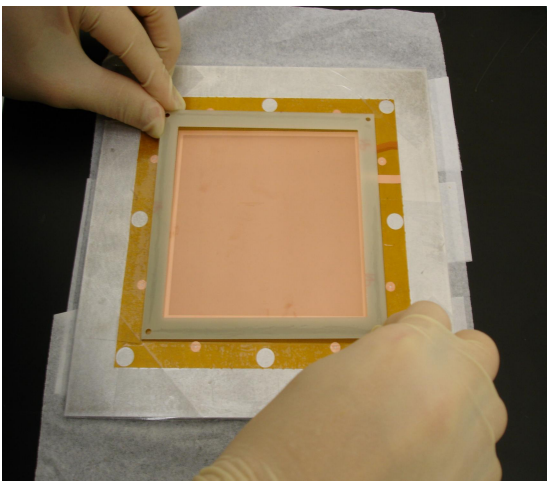

Fig. 1a (left): Mounting of a stretched GEM foil on a G10 frame. Fig. 1b(right): Stack of 3 GEM foils mounted on the lid of the gas box and connected to HV feedthroughs.

2.1.2 Gas box and gas supply system

This completed GEM stack was installed in a stainless-steel box that provided the gas volume for the triple-GEM detector. Students had previously prepared the gas box with feedthrough connectors for high voltage and pick-up signal in the lid of the box, and gas inlet and outlet on the sides (Fig. 2a). Thin Viton o-ring material was used to make a track for an ^{55}Fe X-ray source inside the box. The students designed and built shielding for this x-ray source so that it could be moved inside the closed box with an external magnet to either shield the detector from the source or to expose it to the source. The students also installed a simple open-circuit gas system using stainless-steel piping, a manual flowmeter, pressure regulators and gauges to supply the gas box with a continuous flow of either pure nitrogen for HV stability tests or of an Ar/CO₂ (80:20) gas mixture, which was used as the counting gas for the GEM detector (Fig. 2b).

During the spring semester 2006, sealing the gas box sufficiently from the surrounding air atmosphere posed an unexpected challenge for the project. The original off-the-shelf sealing mechanism between box and lid using tabs and screws proved completely inadequate as it applied too little and uneven pressure on the lid and produced gas leaks. The initial suspect for the site of the leak was the o-ring between box and lid. The ¼-inch Viton o-ring was replaced with a 5/16-inch Viton o-ring (see Fig. 2a), which was glued onto the rim of the box and allowed more compression. Julian Spring designed steel bars using the Autodesk Inventor CAD program to clamp the lid of the box down more uniformly. These ½-inch steel bars had a cutout in the middle to make room for the connectors on the lid. After receiving the bars from the machine shop he discovered that the plates on the bottom of the box were only tack-welded on and were not strong enough to hold under the needed amount of pressure. This required him to make a second set of bars to go underneath the box and give the bolts a set of solid bars to pull against.

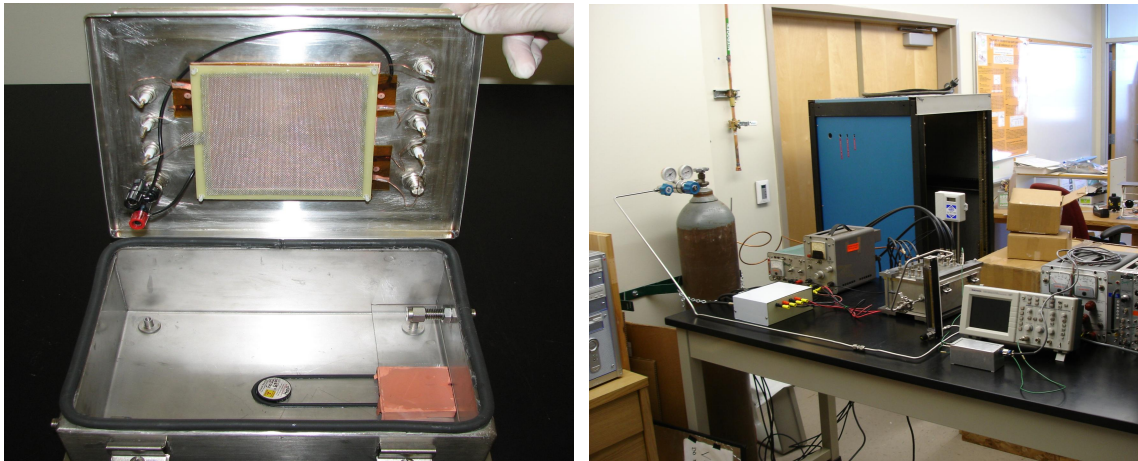

Fig.2a (left): Triple-GEM stack mounted on lid of gas box with HV and gas feedthroughs. A track and “garage” for an ^{55}Fe X-ray source is visible at the bottom of the gas box, which allows the source to be moved externally with a magnet to turn X-ray exposure on an off. Fig.2a (right): Experimental setup with gas box, gas supply system and HV supply system.

The students used three mechanical pressure gauges independently to confirm that they gave equivalent results for the leakage rate of the gas box. However, no significant reduction in the leakage rate was observed after these efforts, which was puzzling. After a number of test, graduate student Szabolcs Rembeczki finally decided to test whether our SHV feedthroughs were actually internally gas-tight. The students pressurized the box to 30 kPa and put a layer of soap water over the feedthroughs and observed bubbles forming quickly from the inside of the feedthroughs. They tested every point on the box where gas might leak from and found that all the SHV feedthroughs and one BNC signal feedthrough leaked internally, whereas the external seals between feedthroughs and box lid were gas-tight.

Since Stycast epoxy glue is an extremely good electrical insulator, it was decided to use it as an internal sealant for the HV feedthroughs as well as the BNC feedthrough. The students carefully placed two beads of Stycast epoxy glue into each connector; one at each point where gas might leak through. After applying this seal, the leakage rate was found to be reduced by a factor of about 100. However, the gas box was still leaking to some extent, which prompted the purchase of a commercial electronic leak-hunter. Using this device it was shown that the compression of the o-ring was still not sufficient for a complete seal. Consequently, large C-clamps were employed together with a new set of stainless steel plates produced by the students in the machine shop to apply more pressure and to finally bring the leak rate down to a satisfactory level. These unexpected leak problem were eventually overcome, but caused a significant delay in the project.

2.1.3 High voltage circuit board

High voltage was supplied to the GEMs using two DC-to-DC converters (EMCO G40) that take low voltage to max. 4000 V high voltage together with voltage dividers made from chains of large resistors. One converter supplies the voltages across all GEM foils, while the other converter maintains the potential difference between the drift cathode mesh and the top GEM. A previously existing HV board with a single resistor chain was upgraded to have three independent resistor chains, i.e. one for each GEM. This was done as a precaution so that a short occurring across one GEM would not affect the high voltage across another GEM because any sudden HV increase across a GEM can lead to sparks that can permanently short out a GEM and thus destroy it. The HV board was mounted in an HV box which the students outfitted with SHV feedthrough connectors.

2.1.4 Leakage current monitor

The leakage current across each GEM was monitored with 3 Keithley picoammeters. To connect these to the HV system, it was required to connect SHV to BNC for the picoammeter input and banana plug back to SHV for the output. Julian Spring built three such adapters that allowed simple connections from the HV circuit board to the picoammeters and from the picoammeters to the detector setup. In addition it was necessary to disconnect the GROUND-to-chassis LO jumper on the picoammeters in order to keep their HV input floating.

2.2 Detector testing and Commissioning

2.2.1 Measurements of leakage currents

The DC-DC converters were calibrated and showed the expected linear behavior for V_{out} vs. V_{in} . With all GEMs connected to picoammeters all GEMs in the system could be tested simultaneously. It was observed that it took some time before currents settled down and everything could be taken up to full voltage. The first GEM to give problems was the original GEM 3 at the top of the stack, which would show a leakage current of a few nA at $V_{GEM} \sim 30V$, but would only hold that for a few minutes and then jump into the μA range. The GEM was repeatedly powered up and down and it always showed that same effect, even after cleaning the GEM and prolonged gas purging. The final attempt to make it behave was to leave the GEM under voltage and drawing current overnight to see if it could be trained, or if any microscopic particles lodged in the holes could be burned off. This attempt was unsuccessful and a new GEM foil had to be framed and installed. This new GEM foil turned out to have the best behavior of all the operational GEMs, holding steady at $I_{leak} \sim 7$ nA under full operational voltage.

After installation of the new GEM 3-003 foil in the setup it was found that the original GEM 1-001 at the bottom of the stack was now also showing a larger leakage current than its neighbors. A plot of this behavior is shown in Fig. 3. Note that the designation GEM 1, GEM 2, GEM 3 indicates the GEM position in the stack, whereas the notation GEM ..-001, GEM ..-002, etc. identifies a particular GEM foil. Repeatedly testing the GEM 1-001 foil both individually and with the other GEMs powered showed the same results. The GEM 1-001 foil was deinstalled, cleaned thoroughly with isopropanol, dried out, and reinstalled, but that did not change its behavior. This forced us to mount the final remaining GEM from the BNL set in a new G10 frame and install it at

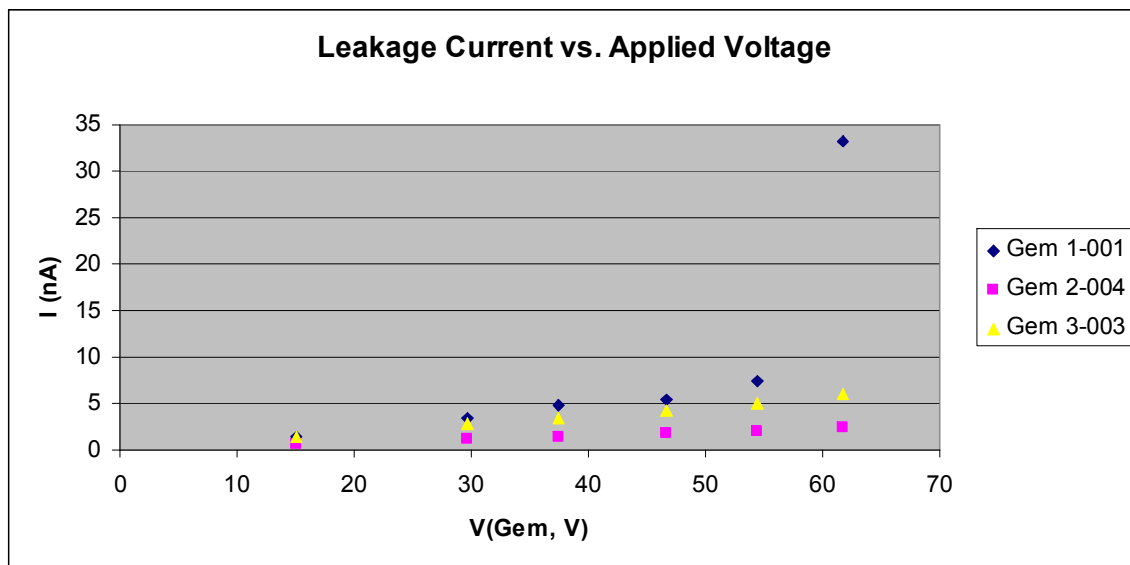

Fig.3 Leakage current across GEM foils vs. voltage applied across GEMs for the original GEM 2-004 (good) and GEM 1-001 foils (bad) and the replaced GEM 3-003 foil (good).

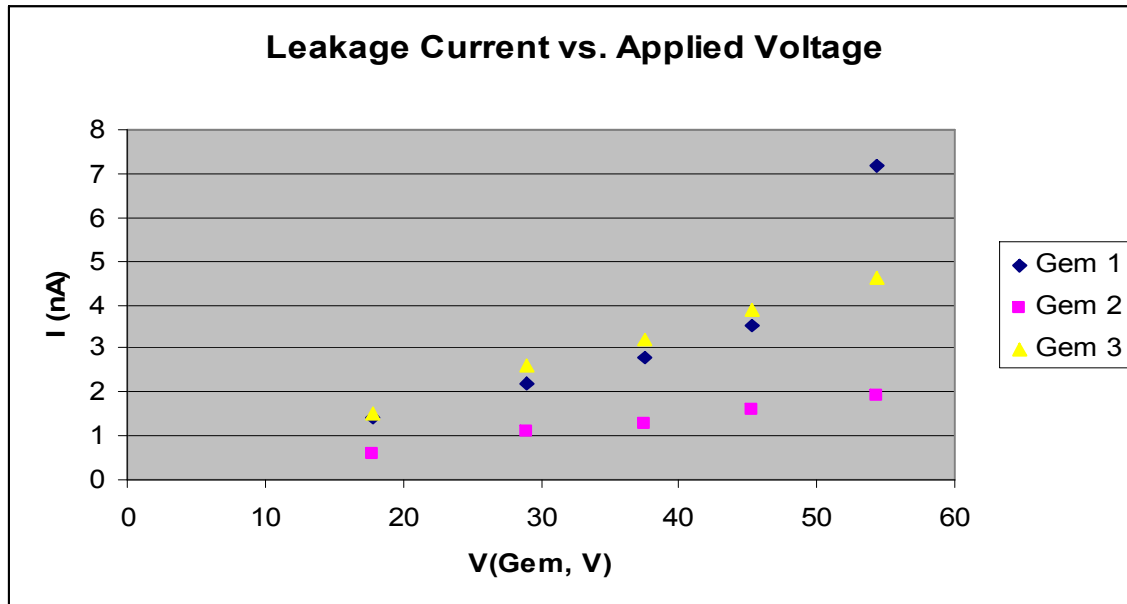

Fig.4 Leakage current across GEM foils vs. voltage applied across GEMs for the original GEM 2 and the replacement GEM 1 and GEM 3 foils.

the GEM 1 position in the GEM stack. In this configuration reasonably low leakage currents were measured for all three installed GEMs as shown in Fig.4. During this testing phase it was observed that the leakage current also depends on a foil's position in the stack. The arrangement G1-004, G2-001, G3-003 appeared to be the best in terms of lowest overall leakage currents.

At nominal operating voltages of $V_{GEM} = 300V$, G2 had a leakage current of 6.6 nA and G3 showed 1.6 nA. At $V_{G1} \sim 240V$ the picoammeter attached to G1 made a sparking noise and the display fluctuated rapidly. Running G1 alone with G2 and G3 disconnected but leaving the drift cathode powered showed the same thing. Since G1 sits at the most negative absolute potential of about -3000 V in the voltage divider, it was concluded that the floating picoammeter could not internally handle such a large potential. Consequently we monitored only the currents from G2 and G3 while the setup was running at full high voltage; both foils showed leakage currents less than 10 nA.

2.2.2 Search for a detector signal

Being confident that the GEMs were behaving reasonably well, by the end of summer 2006 the student attempted to pick up a detector signal using a charge-sensitive integration amplifier (IO1195-1 Rev.A, Fig.5) that we also obtained for free from the BNL Physics Department. Coupling the signal directly into the detector produced no initial results. With a simple signal generator he started getting a signal at the amplifier output at the correct frequency.

The majority of the work in the fall 06 semester was devoted to studying the amplifier, which was a 10-pin chip that required $\pm 5 V$ to power it and had a differential output. The preliminary testing of the chip was on a simple breadboard, which proved not

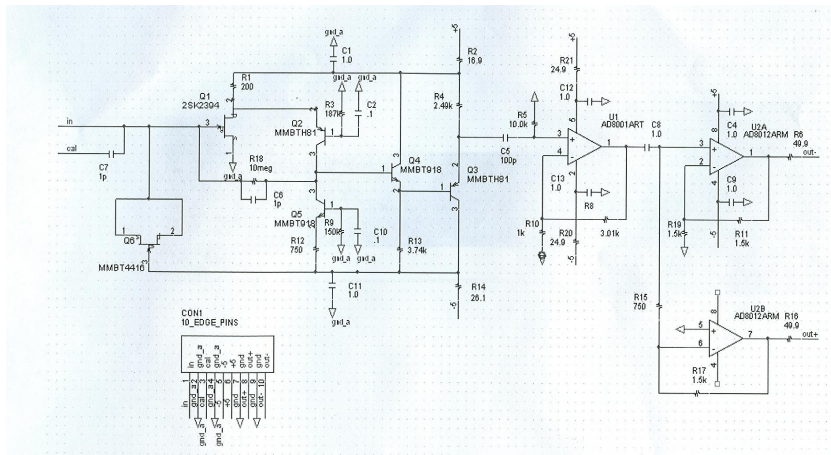

Fig.5 Circuit and pin diagrams for charge-sensitive amplifier IO1195-1 (Rev.A) with differential outputs obtained from the Physics Dept. at BNL.
 (Ref.: http://www.phenix.bnl.gov/WWW/TPCHBD/Chi_DC-EC_3-9-05.ppt)

to be ideal for the sensitivity of the chip. At first the chip was easily driven into oscillations, making it almost unusable. Eventually, through better grounding, the students no longer saw the oscillations and could see a test signal from a signal generator.

A major improvement with the amplifier came when students constructed a metal box to house and shield the amplifier during operation. Once the box was properly grounded to the chip, the students observed cleanly amplified test pulses virtually free from noise. The height of the output signal was proportional to the length of the pulse; pulses that were too long saturated the output as expected. The students also found that the amplifier worked with generated input pulses as fast as a few tens of nanoseconds, which is well-suited for the purpose of the GEM detector which is expected to produce fast pulses with rise-times of a few ns. Students also tested the induction plane by grounding the lid and applying a voltage to the plane, which produced a pulse at the amplifier output. With the amplifier working, the students expected to see a real signal coming from the detector, but could not observe any pulses corresponding to the detection of 5.9 keV X-rays from the ^{55}Fe source. After flushing the box with Ar/CO₂ for many hours and running the GEM foils up to full voltage, students still did not see a signal.

This negative result led to a re-check of all the subsystems that were considered operational until this point. Checking the voltages across the GEM foils confirmed that the potential across a GEM could reach more than 350 V, which should produce sufficient GEM gain to detect 5.9 keV X-rays. Visual inspection of the foils showed no damage to the foils that had not existed previously. Since the foils showed leakage currents of <10 nA, the foils were clearly not shorted. It was found that the drift field needed to be adjusted slightly since the voltages applied assumed a 3 mm separation. To maintain a drift field of 9 kV/cm with the actual 4 mm separation, the input voltage to the drift cathode DC-DC converter needed to be increased from 2.7 V to 3.6 V. The separation between the foils was also found to be 0.2 mm greater than the field calculation assumed, so the field strength between foils was only 94% of what was

expected. However, this small deviation should not have affected the functionality of the detector significantly.

In spring 2007, it was finally decided to replace all the GEM foils. Since there was nothing obviously wrong with the setup, we suspected that one or more of the foils had internal defects resulting in a problem with the gas gain. A set of 7 new GEM foils were purchased from a commercial vendor, TechEtch, with funds provided from this grant. Since the new foils had a somewhat different geometry than the original foils from BNL, students spent most of the spring 2007 semester and the summer of 2007 making new G10 frames and new tools for stretching and mounting the new GEM foils on the frames. At the time of this report, 3 new GEM foils are being mounted into the gas box and we expect to resume testing and commissioning shortly.

3. Technical Conclusion and Outlook

A triple-GEM prototype detector system including HV and gas delivery systems was successfully constructed. The detector is not yet operational due to suspected problems with the original GEM foils, which are being replaced by new foils. We will continue this project until the detector becomes fully operational and can detect X-rays. To address GEM foil problems we will acquire a TeraOhm-meter to help us characterize the resistive properties of GEM foils better. We also plan to acquire a multi-channel HV supply with current monitoring capabilities to improve our HV delivery system and to eliminate any noise injection into the detector due to the DC-DC converters. In addition, we will purchase an oxygen-meter and a hygrometer with sensitivities in the ppm range to monitor the quality of the counting gas.

4. Educational Impact

The project has had a significant impact on the education of the involved students. Especially the many challenges encountered during the project have provided a valuable learning experience for the students and an example for the importance of patience and perseverance in experimental physics. For the graduate student, Szabolcs Rembeczki, the project represents his main experimental experience during his graduate career since he is now mainly working on a computer simulation project for the design of high-field magnets in cooperation with the Advanced Magnet Laboratory, Melbourne, for his Ph.D. dissertation.

Several undergraduate students received formal credit for the work they performed on this project in “Undergraduate Research” courses given by the P.I. For these courses they produced a number of research reports on this project (see section 6). Julian Spring also chose to present the project as his topic in the “Senior Seminar”, which is a required course for all physics seniors. Two students gave talks on the project at the 2005 and 2006 annual meetings of the Florida Academy of Science on behalf of our GEM research group.

Two of the main students on the project are now in physics Ph.D. programs at very reputable institutions. Rob Damadeo graduated with a B.S. in physics in May 2006 and was accepted into the Ph.D. physics program at Johns Hopkins University in fall

2006. Julian Spring graduated with a B.S. in physics in December 2006 and is starting a Ph.D. program in experimental particle physics at Boston University this fall. David Dickey graduated in May 2007 and is expected to enter a physics graduate program in the near future. David had also been previously funded on an FSGC summer student internship in 2004 under the supervision of the P.I..

One of the key students currently active in the project, junior Nick Leioatts, is also showing a strong interest in experimental physics and detectors for particle detection. He was selected for an internship at Fermi National Accelerator Laboratory in Batavia, IL in summer 2006. An official technical note based on a study that he contributed to during his internship was recently released to the CMS experiment, one of the large international collaborations at the Large Hadron Collider at CERN, Switzerland. Nick also was accepted with a fellowship into the U.S. Particle Accelerator Summer School at Michigan State University in summer 2007 where he took an introductory class on accelerator physics and technology for college credit.

5. Follow-up Funding

One of the goals listed in the proposal for this grant was to use this work and funding as leverage towards obtaining a larger grant for the development of GEM detectors in applications outside of high energy physics. The P.I. is happy to report that this effort has been very successful. In May 2007, Dr. Hohlmann was awarded a \$229,000 one-year contract with the Domestic Nuclear Detection Office (DNDO) in the Department of Homeland Security (DHS) with the option for an additional \$1.1 million continuation contract for years two and three.

Under this contract the P.I.- together with a Fl. Tech faculty in computer science, a physics post-doc, electronics engineer, graduate students, and undergraduates - will investigate the application of GEMs in large scale detectors for cosmic ray muons. The goal of this project is to measure the scattering of muons in cargo with high precision in order to detect nuclear contraband hidden in that cargo. This muon radiography/tomography application has good prospect for detecting heavily shielded nuclear material that might be smuggled into the U.S. by terrorists for a nuclear explosion device or a “dirty bomb” and that might be very difficult to detect with currently employed standard cargo scanning techniques. Year 1 is devoted to computer simulations and studies of such scenarios and in years 2 & 3, large GEM prototypes will be developed drawing on our experience gained in the FSGC-sponsored GEM project.

6. Related Reports and Presentations

- Reports:
 - Julian Spring with R. Damadeo, D. Dickey, T. Garlick, M. Hohlmann, S. Rembeczki, Development of a Triple-GEM Particle Detector at Florida Tech, Senior Seminar Report, Dec 2006.
 - David B. Dickey, Experimentation with Gas Electron Multiplier (GEM), UG Research Report, Dec 14, 2006.
 - Julian Spring, Report of Work Done on Triple-GEM Detector During the Summer of 2006, UG Research Report, Sep 17, 2006.
 - Julian Spring, Undergraduate Research Semester Report, May 2006.

- Presentations:
 - Rob Damadeo, with S. Rembeczki, D. Dickey, T. Garlick, N. Leioatts, J. Spring, A. Trivedi, Detection System for Ionizing Radiation, presented at the 70th annual meeting of the Florida Academy of Science, Florida Tech, Melbourne, March 10, 2006.
 - D. Dickey, with J. Slanker, K. Dehmelt, M. Hohlmann, L. Caraway, High Energy Particle Detection through Prototype Gas Electron Multiplier Systems, presented at the 69th annual meeting of the Florida Academy of Science, U. of South Florida, Tampa, March 18, 2005.