

# Climate change and adaptation in African agriculture



**Prepared for Rockefeller Foundation**

**By Stockholm Environment Institute**

Gina Ziervogel, Anton Cartwright, Adriaan Tas, James Adejuwon,  
Fernanda Zermoglio, Molihi Shale and Ben Smith

**March 2008**

## Table of Contents

Executive summary.....	2
List of Acronyms .....	5
Chapter 1: Introduction .....	7
Chapter 2: Research approach .....	9
Chapter 3: Climate change and African agriculture – an overview .....	11
3.1 Climate change science.....	11
3.2 Climate impacts on agricultural development.....	17
3.3 Climate adaptation and agricultural development.....	19
Chapter 4: Institutions and programs active in African climate science and agricultural adaptation.....	22
4.1 Donors involved in climate science and agricultural adaptation.....	23
4.2 Key research institutions.....	28
4.3 Key practitioner institutions involved in climate adaptation.....	33
4.4 Producers and users of climate projection data in Africa .....	35
Chapter 5: Key Findings .....	36
5.1 The context of climate change adaptation in Africa.....	36
5.2 The state of climate change science in Africa.....	37
5.3 The use and application of climate change projection data in Africa .....	39
Chapter 6: Recommendations.....	43
6.1 Improving and expanding climate change projection data in Africa.....	43
6.2 Bringing data producers and data users together .....	43
6.3 Improving capacity to interpret and apply climate data .....	44
6.4 Move from awareness raising to ”proof of concept” .....	44
6.5 Platforms as the backbone for collaborative action and information sharing.....	44
6.6 Focused donor funding.....	45
6.7 Placing climate change within the broader African development context .....	46
Bibliography.....	48
Appendix A: Stakeholders interviewed.....	52

## Executive summary

### 1. Background

This study, commissioned by the Rockefeller Foundation, set out to identify and understand the extent to which, and ways in which, information from climate change models is being integrated into agricultural development practice and decision making in Africa.

### 2. Overview of climate data for Africa

The development of climate projections for Africa is evolving rapidly. General Circulation Models (GCMs) now project climate parameters at a resolution of 250 km<sup>2</sup>, while downscaled models provide projections at 50km<sup>2</sup>. The science of climate modeling is complex and efforts to communicate this science to agricultural users remain rudimentary and fraught with what are perceived to be contradictory and unreliable messages. Within the climate science community there is an emerging effort to make findings more suitable for decision making, but as yet there is very little consensus as to how data may be relied on for decision making.

### 3. Nature of climate data used in Africa

While awareness of and references to climate change are both increasing, this is mainly based on highly aggregated data from the IPCC Data Distribution Centre and GCMs. The climate data that are used within African agriculture are generated by a few key international organizations. These include the UK Met Office's Hadley Centre and their dynamical downscaling PRECIS model, NOAA (National Oceanic and Atmospheric Administration, USA) and CNRS (Centre National de la Recherche Scientifique, France) General Circulation Model (GCM) data are used to provide seasonal climate forecasts for Africa. The use of these data is based on their accessibility and familiarity to the users, rather than their suitability to the specific problem or research question being addressed. As such there is very little discernment of the relative merits of different climate models for specific regions or purposes, even though models differ markedly in their utility for specific regions and parameters.

### 4. Approaches to downscaling in Africa

A number of African-based research projects use a single GCM model with local climate data to run dynamical and empirically downscaled models. Downscaling based on a single GCM amplifies the limitations of that GCM. Relative to downscales that rely on multiple models, downscales based on a single GCM permit limited local inference.

### 5. Local climate modeling institutions

Modeling of African climate is limited from within Africa. The only African institution that is generating empirical downscaled climate data based on multiple models is CSAG at the University of Cape Town, but applications and further analysis based on this data remain limited. ACMAD, in West Africa, and ICPAC, in East Africa, have focused on providing seasonal climate information but are starting to explore climate change scenarios primarily by using PRECIS, a Regional Climate model (RCM). National Meteorological Services

have previously not been mandated to work on climate change but in many countries they are starting to explore these issues.

#### **6. Responding to climate variability versus climate change**

Whilst African agriculture has always had to, and continues to, adapt to changing environmental circumstances (including climate), there is a danger that this adaptation with its focus on climate variability, will not take cognizance of the trends imposed by anthropogenic climate change.

#### **7. Application of climate change data**

Amongst farmers, applications of the existing downscaled data in decision making is limited to a few progressive and long-term farming schemes and agribusinesses. This is unsurprising as there is currently very little evidence that short-rotation crop farmers stand to benefit from using the available climate data in their decision making due to the temporal and spatial scale at which this data are reported.

What is conspicuous is that very few agricultural policy makers, crop breeders and donor agencies - whom one might expect to adopt a longer-term and more strategic focus - apply the available climate data in their program formulation.

#### **8. Evidence of adaptation to climate change**

There are currently very few “proofs of concept” – that is examples of agricultural decision makers that have successfully drawn on climate change projection data to take decisions that have improved agricultural productivity or human well-being. This is a function of the temporal and spatial at which climate data are provided as well as the way in which they are reported, perceived in terms of the reliability of the data, questions of their relevance to agriculture, and difficulty in accessing and understanding the data.

To address this “disconnect” between climate science and African agriculture, capacity capable of linking existing climate data and agricultural decision making needs to be created. This is as much an institutional challenge as it is a technical and human resource challenge.

#### **9. Developing multi-disciplinary adaptation capacity**

The nature of climate change adaptation demands that efforts to support African agriculture in the face of climate change incorporate a multi-disciplinary set of stakeholders including climate science experts, agricultural practitioners and technicians, local communities/civil society, donors and policy makers. A key challenge involves extending the capacity that currently exists in agro-meteorological disciplines to include agro-climatic competency.

Local “climate change adaptation platforms” have been proposed by a number of development agencies, as a means of promoting collaboration between scientists and practitioners, and enhancing local adaptation capacity including the ability to draw on climate data. It is essential that these institutions design their activities around local needs and not the funding or reporting requirements of the international climate change community.

#### **10. Support processes not projects**

Climate change adaptation is, at its best, a social learning process that equips local decision makers to respond to a wide range of difficult to predict contingencies brought on by perturbed climates. Although once-off projects are capable of delivering technical capacity and social learning, experience has shown that creating the capacity to apply climate information is a resource intensive process that takes time. Therefore it is important that funding for climate change adaptation goes beyond pilot projects and once-off interventions, and instead allows local institutions to explore the relevant issues and develop the broad set of institutional capacity and technical skills that will equip them for the challenge. Developing the necessary independence and stability will require a lot of inputs from different stakeholders. For donors this presents the challenge of ensuring that funding for processes, which is more difficult to monitor than funding for projects, still delivers robust benefits and value for money.

## List of Acronyms

ACCCA	Advancing Capacity to support Climate Change Adaptation
ACMAD	African Centre of Meteorological Applications for Development
AERC	African Economic Research Consortium
AGRA	Alliance for a Green Revolution in Africa
AGRHYMET	Centre Régional de Formation et d'Application en Agrométéorologie et Hydrologie Opérationnelle
AIACC	Assessments of Impacts and Adaptations to Climate Change
CCAA	Climate Change Adaptation in Africa
CCE	Climate Change Explorer tool
CEEPA	The Centre for Environmental Economics and Policy in Africa
CGIAR	Consultative Group on International Agricultural Research
CLACC	Capacity Strengthening for Least Developed Countries (LDCs) for Adaptation to Climate Change
ClimDev	Climate for Development in Africa
CLIP	Climate Land Interaction Project
CSAG	Climate Systems Analysis Group (University of Cape Town)
DFID	UK Department for International Development
DGIS	The international cooperation department of the Netherlands Ministry of Foreign Affairs
ENDA-TM	Environment and Development Action in the Third World
FAO	UN Food and Agriculture Organization
FEWSNET	Famine Early Warning System Network
GCM	General Circulation Model
GEF	Global Environment Facility
GCOS	Global Climate Observing System
GTZ	German Agency for Technical Co-operation
IAR&T	Institute for Agricultural Research and Training
ICPACIGAD	Climate Predictions and Applications Centre
ICRAF	International Centre for Research in Agro forestry
ICRISAT	International Crops Research Institute for the Semi-Arid Tropics
IIASA	International Institute for Applied Systems Analysis
IIED	International Institute for Environment and Development
IITA	International Institute for Tropical Agriculture
IPCC DDC	Intergovernmental Panel on Climate Change Data Distribution Centre
LEAD	Inspiring Leadership for a Sustainable World
MOE	Ministry of Environment
MSU	Michigan State University
RCM	Regional Climate Model
SDSM	Statistical downscaling methodology
SEI	Stockholm Environment Institute
SIDA	Swedish International Development Agency
SSN	SouthSouthNorth
START	Global Change System for Analysis, Research and Training

UCT University of Cape Town  
UK Met Office Office for weather and climate change forecasts for UK and worldwide  
UNDP United Nations Development Programme  
UNEP United Nations Environment Programme  
UNFCCC United Nations Framework Convention on Climate Change  
UP University of Pretoria  
USAID United States Agency for International Development

## Chapter 1: Introduction

This study, commissioned by the Rockefeller Foundation, set out to identify and understand the extent to which, and ways in which, information from climate change models is being integrated into agricultural development practice and decision making in Africa<sup>1</sup>.

To this end it focused on three activities:

1. Locating the landscape: A description of the current knowledge linking climate change models with African agricultural development practice, and an identification of the institutions and stakeholders involved in the associated activities.
2. Barriers to using climate change data: The challenges confronted by agricultural development programs and farming communities in Africa that are seeking to access and use information are presented.
3. Climate data recommendations: The identification of options and opportunities for improving the uptake of climate information for developing adaptation responses

Adaptation to climate variability is not new, but climate change is expected to present heightened risk, new combinations of risks and potentially grave consequences. This is particularly true in Africa where direct dependence on the natural environment for livelihood support combines with a lack of infrastructure and high levels of poverty to create vulnerability in the face of all types of environmental change. Accordingly there is a growing focus on the need for “anticipatory adaptation” (UNDP, 2007), that is the proactive rather than the reactive management of climate change risk. Anticipatory adaptation relies on the best available information concerning the nature of future climate risks.

The Rockefeller Foundation, in commissioning this work, acknowledged a need that had been articulated by others (Nyong, 2005; Patt, 2007; Wilby, 2007) namely to gain a better understanding of which institutions were undertaking what work in the rapidly evolving field of climate change adaptation, as well as potential for a better coordination of both donor funded activities and climate science applications. In addition, insight into the perceived disconnect between the rapidly evolving work of climate scientists and the long-standing agricultural development community, was further perceived as being important and was targeted by the study.

The content of this report is structured as follows:

- Chapter 2 outlines the approach that was taken to assessing who the key players were in the field of adaptation to climate change within the agricultural development sector in Africa and establishing the barriers and opportunities to using climate change information within this field.

---

<sup>1</sup> The views expressed in this report are those of the authors and we welcome feedback: [gina@csag.uct.ac.za](mailto:gina@csag.uct.ac.za)



- Chapter 3 presents background information on issues around the production and use of climate science, impacts of climate change on agricultural development and the potential for adaptation.
- The material from the interviews is presented in Chapter 4, summarizing the focus and role of different institutions including representatives from the donor, climate science, agricultural development and adaptation communities.
- Chapter 5 draws on the interview material to present key findings and is followed by Chapter 6 that proposes some recommendations in order to address the barriers and opportunities for using climate science for adaptation within the agricultural development sector in Africa.
- The final chapter presents recommendations for improving the value of existing and future climate science for use in agricultural adaptation.

## Chapter 2: Research approach

The study commenced with a review of literature and a web search aimed at identifying the key issues and players in the field. This led to the compilation of a database that identified and described a broad set of institutions working on climate change modeling and agricultural development (including land and water management) in Africa. This included individuals and institutions focused on agriculture, a limited number of institutions supporting climate adaptation, development oriented donors and agencies, researchers and climate scientists.

The agricultural focus of this study was limited to crop and livestock production. This is in spite of notable impacts on forestry and fisheries which were excluded from this report.

Institutions in the database are clustered according to:

- Whether or not they use climate change scenarios
- Whether or not they use data on current climate variability
- The institution's work focus (e.g. crop development, water management, climate change impacts, seasonal forecasting),
- Whether or not the institution has expressly developed or supported climate adaptation strategies.

While the database is not exhaustive of the key players or their activities in this rapidly expanding arena it does provide a useful oversight. By clustering stakeholders according to their activities the database enables the identification of potential duplications and synergies – something that has emerged as a priority in previous studies (Nyong, 2005; Wilby, 2007). Although there was an attempt to report the financial resources committed towards climate change adaptation by respective institutions, very few institutions separate climate adaptation funding from general budgets, and reporting on budget allocations is incomplete.

The database also assisted the research team in identifying candidates for the next phase of the study which involved in-depth interviews. Drawing on the database and the researchers' experience in the field in an attempt to ensure a representative spread across the disciplines of climate science, climate impacts, vulnerability and adaptation, agricultural development and climate variability, forty one interviews were conducted. The interviews provided the researchers with detailed insight into the activities of specific institutions and particularly the ways in which they were (and in some instances were not) using climate information.

Interviews, some of which were conducted in person<sup>2</sup> and some on the telephone, followed the format of semi-structured questionnaires aimed at establishing the following:

---

<sup>2</sup> The Conference of Parties in Bali (December 2007) provided a fortuitous convening of experts and enabled the research team to conduct a number of in-person interviews at low cost.

- An overview of the institution's climate change strategies, strengths and adaptation pathways currently in place as well as those required.
- Identifying how different institutions accessed and used climate data.
- Gaps in the network as well as gaps in allied networks (water, health, disaster relief).
- Barriers for potential climate adaptation strategies that are created by climate change data.
- Opportunities for improved climate change adaptation in Africa.
- Identification of the priorities of donors active in this field.
- Threats to current climate adaptation and the development of adaptation strategies, including competing and counter-productive initiatives and prevailing mal-adaptation.

The researchers convened in Cape Town in early February 2008 to reflect on and collate the findings of the interviews. During this time, institutions were further classified into a matrix according to their mandate (donor, research, practitioner) and their own description of their primary focus (climate science, climate adaptation and agricultural development).<sup>3</sup>

The research team further used the time in Cape Town to map the flow of climate change information from its various sources to different decision makers at the local level, and to agree on the salient findings with regards to the use and influence of this information. The interviews themselves, although detailed, provide a rich information resource for future work and available as an appendix to this report.

---

<sup>3</sup> Needless to say a number of the institutions straddled the focus activities. Such institutions were placed in the category most appropriate to their primary focus.

## **Chapter 3: Climate change and African agriculture – an overview**

Climate change is a complex biophysical process. It is not possible to predict precise future climate conditions, but the scientific consensus is that global land and sea temperatures are warming under the influence of greenhouse gases, and will continue to warm regardless of human intervention for at least the next two decades (IPCC, 2007). The increasing concentrations of greenhouse gases in the atmosphere are mainly due to the 80 per cent increase in annual CO<sub>2</sub> emissions since 1970. Most of this historical increase emanated from the industrial activities of developed countries in Europe, North America and Japan, although the burgeoning economies of Brazil, China, India and South Africa have contributed significantly in the past decade. Developing countries, especially those on the African continent have contributed little to the observed global warming. Per unit of GDP produced African economies are the most CO<sub>2</sub> intensive in the world at 1.65 kg of CO<sub>2</sub> equivalent per US \$ dollar of GDP (indexed by 2000 dollars), but the relatively low levels of economic activity on the continent result in low aggregate emissions. The same lack of economic activity and poverty, render African countries, and especially the poorest communities in these countries, disproportionately vulnerable to climate change impacts. In regions of East and Southern Africa, this vulnerability is further heightened by the large number of households that depend on the already marginalized natural resource base for their livelihoods. Agricultural production and the biophysical, political and social systems that determine food security in Africa are expected to be placed under considerable additional stress by climate change (FAO, 2007).

The capacity to investigate these impacts can be enhanced by drawing on the best available scientific information with regards to future climates. This chapter provides an overview of the evolution of climate science, its application to African agriculture and the key dimensions of climate information for adaptation efforts in African agriculture.

### **3.1 Climate change science**

Current research in climate science is focused on a few core lines of inquiry and several excellent reviews are available on the subject (Wilby, 2007). These research lines include 1) measurement, estimation and monitoring of greenhouse gas concentrations in the atmosphere; 2) sensitivity and radiative forcings: scenario development and testing via models of modeling of the earth - ocean - atmosphere system to simulate responses to external stimuli such as those resulting from increasing concentration of greenhouse gases or from projected emissions based on plausible socio-economic futures. This line includes the impacts resulting from the dynamic interplay and feedbacks between greenhouse gas emissions and other climate parameters such as sea surface temperatures; 3) Downscaling of outputs of the General Circulation Models (GCMs) that are used to project global climate change, and 4) the description and translation of future climate data for

practitioners and decision makers at all scales.<sup>4</sup> Climate change science can then be used for modeling the impacts of climate change on agriculture (using crop models for example).

GCMs have been developed to project future climates based on different greenhouse gas scenarios and complex earth atmosphere interactions. As such GCMs provide the means of making climate change projections. The Intergovernmental Panel on Climate Change (IPCC) has defined a set of criteria that have been applied to identify GCM experiments whose results could be deposited at the IPCC Data Distribution Centre (DDC). Among these are physical plausibility and consistency with global projections (Smith and Hulme, 1998). These criteria led to an initial selection of experiments from five modeling centers with the possibility of others to be added to the DDC as they qualify for inclusion.

The IPCC Fourth Assessment Report presented 23 general circulation models (GCMs) that by design span the globe. While some of these models are relevant to Africa and are reported at pixel resolutions of around 250 km<sup>2</sup>, the underlying data used to generate this information are often so highly aggregated so as to undermine their utility at projecting regional climate. Table 1 provides information on where the models agree and if so, the direction of change. However it also indicates that in some areas there is less predictability. Whilst GCMs can more accurately project changes in average global temperature, these projections are often of little use to decision makers working on regional or local scales. Limited recognition of this fact is one of the findings to emerge from the interviews conducted in this scoping study.

Region	December-January	June-August
Sahara	Small decrease	Inconsistent
West Africa	Inconsistent	Inconsistent
East Africa	Small increase	Inconsistent
Southern Africa	Inconsistent	Large decrease

**Table 1:** Models have strengths in different aspects of climate projections and do not necessarily concur on all aspects. Similarly the climate of some regions are innately more predictable than other regions and models tend to agree in their forecasts of these regions. This is illustrated in this summary table of climate model consistency in regional precipitation projections for 2090-2099 under SRES A1B emissions. Regions in which the middle half of all model projections show disagreement on the sign of change are classified as inconsistent. Regions showing model consensus are indicated as small (5-20%) or large (>20%) increases or decreases (Source: IPCC, 2007). The table highlights the importance of selecting the right model for the regional and climate focus as well as the potential merits of using multiple model forecasts.

<sup>4</sup> Future climate data can be broadly separated into seasonal climate forecasts, decadal forecasting and climate change projections or scenarios. Seasonal climate forecasting focuses on projections of rainfall and temperature in the coming year and are widely available ([www.iri.columbia.edu](http://www.iri.columbia.edu)), decadal forecasts of climate projections for the coming 10 years are not well developed (Wilby, 2007) and climate change scenarios focus on the 2040 – 2100 time scale (with a number of Global Circulation Models being available on the IPCC DDC site [www.ipcc-data.org](http://www.ipcc-data.org)).

Nevertheless, growing recognition of the need for climate information at finer scales is itself a driver of the volume of work aimed at downscaling climate model information for local and regional decision makers. Two approaches dominate the downscaling efforts, each based on a specific set of assumptions and methodologies: empirical and dynamical downscaling (also known as regional climate models: RCMs). Figure 1 shows how these different types of climate modeling approaches fit together. These downscaled climate change models take data from GCMs and interpret them in relation to local climate dynamics (Tadross et al., 2005). The difference in pixel resolution between GCMs and RCMs can be seen in Figure 2.

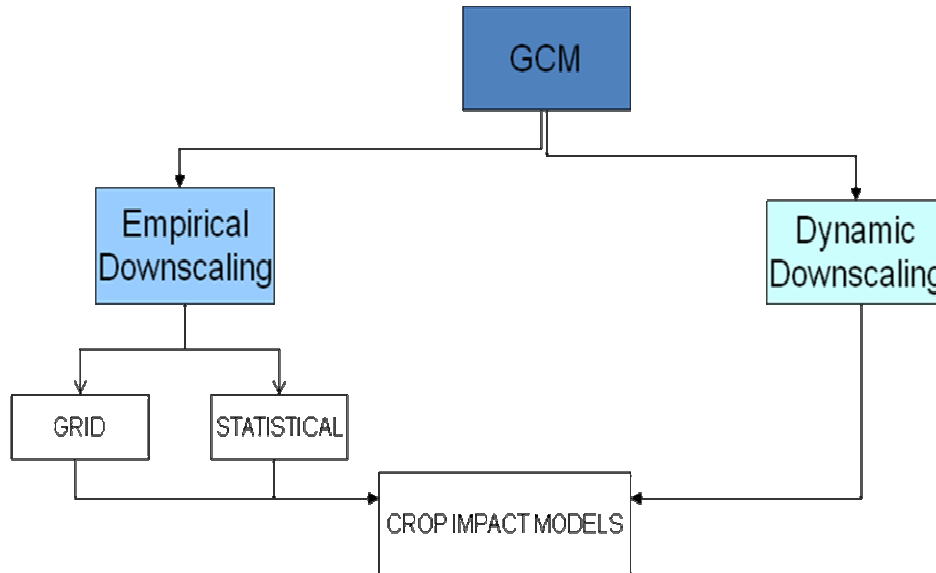

**Figure 1:** Overview of different types of climate models

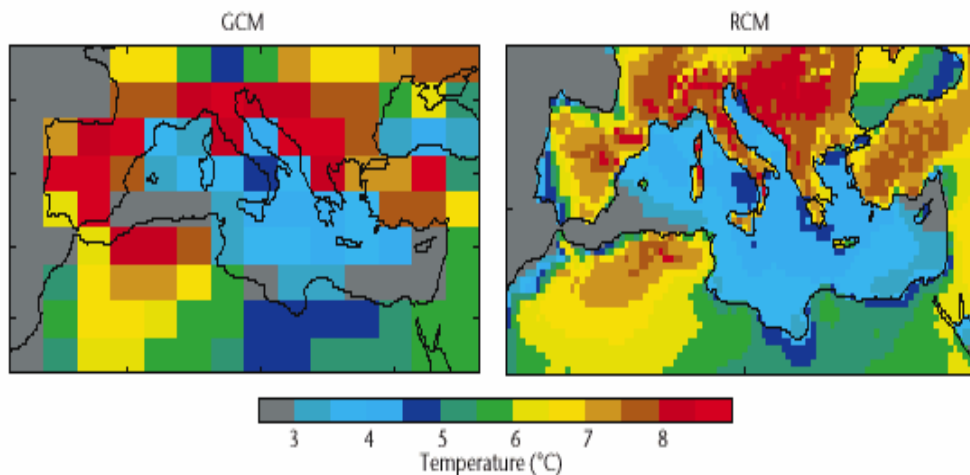

**Figure 2:** GCM versus RCM: Mediterranean temperature changes in summer

*Source:* Jones, R. and Wilson, S. (2002)

- **Empirical downscaling** makes use of the quantitative relationships between the state of the larger scale climatic environment and local variations sourced from historical data. By coupling specific local baseline climate data with GCM output, it provides a valuable solution to overcoming the mismatch in scale between climate model projections and the unit under investigation. Empirical downscaling can be applied to a grid or to a particular meteorological station. The later sub-set of empirical downscaling is more common and referred to as statistical empirical downscaling.

The Climate Systems Analysis Group (CSAG) ([www.csag.uct.ac.za](http://www.csag.uct.ac.za)), based at the University of Cape Town, South Africa, operates the preeminent empirical downscaled model for Africa and provides meteorological station level responses to global climate forcings for a growing number of stations across the African continent. The data requirements (10 years of quality controlled daily climate measurements) and technical skills intensity required for empirical downscaling has resulted in no other institutions in Africa producing such data. Existing adaptation studies and programs have had limited awareness of the availability of such data. This is gradually changing, with a growing number of adaptation and climate impact studies benefiting from the downscaled information provided by this and other downscaling approaches (Wilby and Wigley, 1997; Prudhomme et al., 2003; Wilby and Harris, 2006). Figure 3 below shows the downscaled climate data produced by CSAG, as presented in the IPCC (Christensen et al., 2007). One of the key points is that the six different downscaled projections are showing agreement in the direction of change for rainfall in many parts of Africa.

Another empirical downscaling approach, Statistical Downscaling Methodology (SDSM) has gained some applicability to Africa (Wilby et al, 2002). SDSM applies a single GCM model and requires the user to acquire historical local climate data in order to run the downscaling. Much of the use of SDSM in Africa has been restricted to students who applied this approach in their masters and doctoral dissertations. For example, a research project used SDSM to downscale HadCM3 to estimate the impact of climate change on Ethiopia's Lake Ziway's hydrology to 2099 (Zeray et al., 2006). Changes in climate variables were applied to a hydrological model so as to simulate future flows.

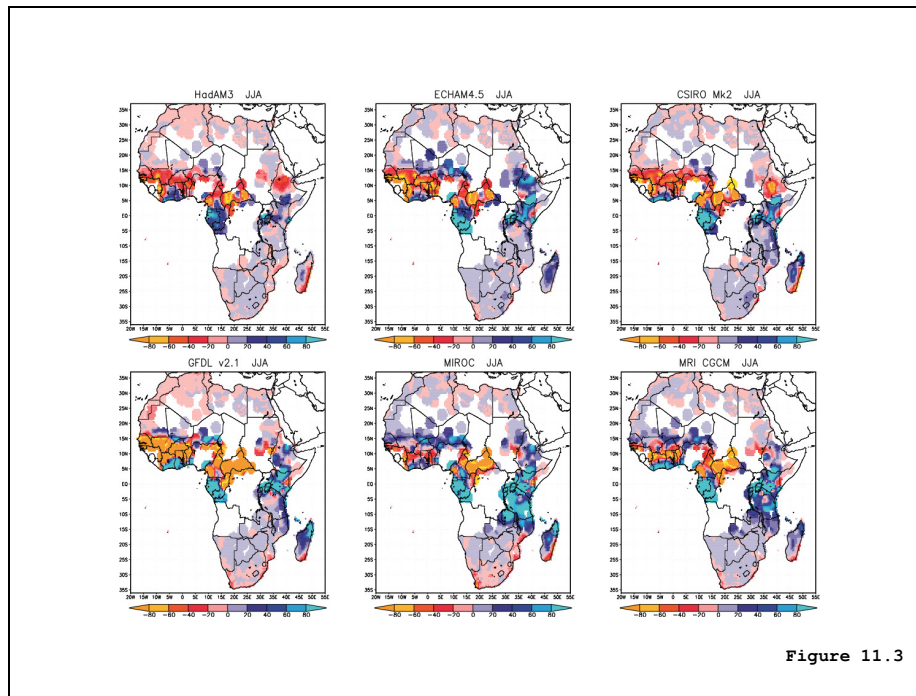

Figure 11.3

**Figure 3:** Anomaly of mean monthly precipitation (mm) using daily data empirically downsampled from six GCMs (ECHAM4.5, Hadley Centre Atmospheric Model (HadAM3), CSIRO Mk2, GFDL 2.1, MRI, MIROC) to 858 station locations. The GCMs were forced by the SRES A2 scenario. Anomalies are for the future period (2070 to 2099 for the first three models, and 2080 to 2099 for the latter three models) minus a control 30-year period (from Hewitson and Crane, 2006).

- **Dynamical downscaling and regional climate models** makes use of the boundary conditions (e.g. Atmospheric parameters from a GCM such as surface pressure, wind, temperature and vapour) and principles of physics within an atmospheric circulation system to generate small scale (high resolution) datasets. Due to its reliance on high-resolution physical datasets, the approach is useful in the representation of extreme events. However, dynamical downscaling is a computationally and technically expensive method, a characteristic that has limited the number of institutions employing the approach. Key among the dynamical downsampled models in use in Africa are the MM5 WRF (Weather Research and Forecasting Model), Darlam (CSIRO, Australia) and PRECIS (Providing REgional Climates for Impacts Studies, UK Met Office) models. PRECIS, a product of the UK Met Office, relies exclusively on the Hadley Centre's GCMs at present, and is the most widely used downsampled model in Africa.

An important component of climate change science involves the description, understanding, and representation of the inherent uncertainties in the modeling efforts. Uncertainty in climate change science is a function of the difficulties of modeling a complex and not entirely understood pair of inter-related systems (i.e. oceans, atmospheres), lack of complete knowledge on natural variability, an imperfect understanding of future greenhouse gas concentrations, and the likely impacts that surprises will bring to the climate system (Stainforth et al, 2007). Whilst it is known that specific models are more “skilled” at predicting specific parameters in certain regions, without a comprehensive exploration of multiple model outputs, choosing a single model



for a specific region is not advisable (IPCC 2007). An analysis of an “ensemble” of models, rather than a single model, is the best way of addressing the uncertainty inherent in making a decision which is influenced by the future evolution of the climate system. These “envelopes” – as the multiple model outputs are called - of climate change help define the range of potential climate change based on a number of multi-model projections. Whilst envelopes do not provide the type of discrete answers that some decision makers seek, they do allow analysis based on different models. This provides decision makers with valuable perspective on what might be expected. It also allows decision makers to collate the projections of different models to find points of maxim (and very little) concordance, which in turn can be used to attach the appropriate level of confidence to projections and associated decisions. Wrongly assumed confidence in climate projections can be as dangerous (sometimes more dangerous) than having no projection at all. Figure 4 provides an example of the envelope approach by taking three different downscaled precipitation anomaly scenarios for a location in Mali. The outer range of the combined model projections provides the “envelope” within which precipitation is expected to change.

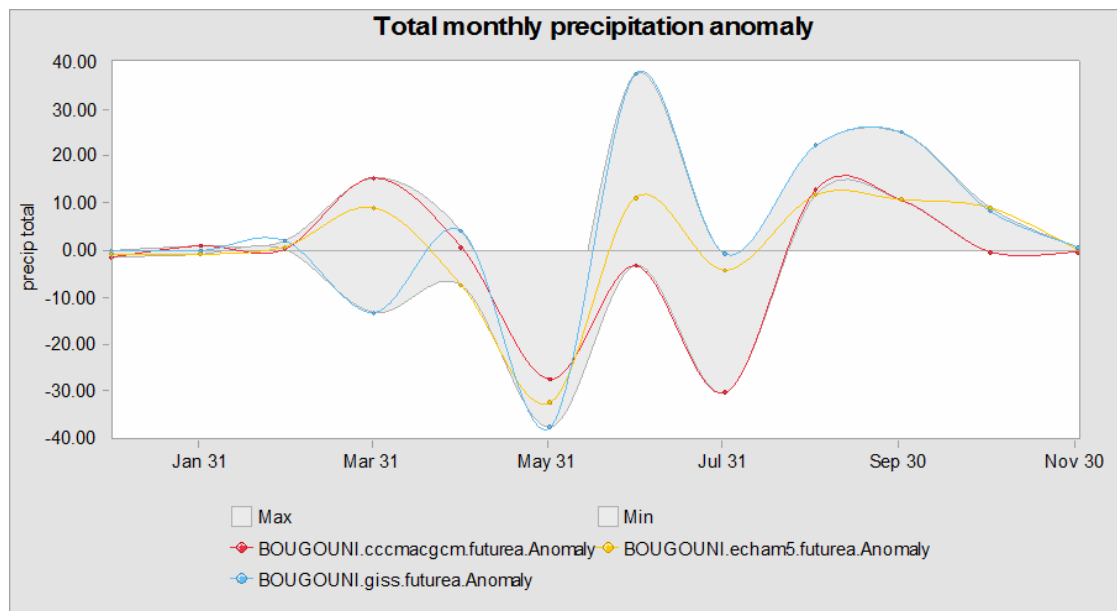

**Figure 4:** Modeled change in total monthly rainfall for Bougouni, Mali. Different colors represent different model projections while the gray area denotes the envelope. Sample output from the Climate Change Explorer indicating model agreement in the changing distribution of rainfall from March through September, which comprise the growing season for this region in Mali.

Central to the approach adopted by (CSAG) is the Climate Change Explorer, a tool designed to simplify the tasks associated with the extraction, query and analysis of climate information. The intention is to enable users to address issues of uncertainty when devising policies and strategies, and when implementing actions. This Climate Change Explorer Tool facilitates crucial links between understanding vulnerability, monitoring and projecting climate hazards and planning adaptation processes. Figure 4 was produced using the Climate Change Explorer.

### 3.2 Climate impacts on agricultural development

The IPCC's Fourth Assessment Report summary for Africa describes a trend of warming at a rate faster than the global average, and increasing aridity (see Text Box 1). Climate change exerts multiple stresses on the biophysical as well as the social and institutional environments that underpin agricultural production. Some of the induced changes are expected to be abrupt, while others involve gradual shifts in temperature, vegetation cover and species distributions. Climate change is expected to, and in parts of Africa has already begun to, alter the dynamics of drought, rainfall and heatwaves, and trigger secondary stresses such as the spread of pests, increased competition for resources, the collapse of financial institutions, and attendant biodiversity losses.

Predicting the impact of climate change on complex biophysical and socio-economic systems that constitute agricultural sectors is difficult. In many parts of Africa it seems that warmer climates and changes in precipitation will destabilise agricultural production. This is expected to undermine the systems that provide food security (Gregory et al., 2005). Whilst farmers in some regions may benefit from longer growing seasons and higher yields, the general consequences for Africa, as reported in Text Box 1, are expected to be adverse, and particularly adverse for the poor and the marginalized who do not have the means to withstand shocks and changes.

**Text Box 1: Key attributes of the IPCC's Fourth Assessment Report for Africa**

Source: Christensen et al. 2007, p.850

- Warming is *very likely* to be larger than the global annual mean warming throughout the continent and in all seasons, with drier subtropical regions warming more than the moister tropics.
- Annual rainfall is *likely* to decrease in much of Mediterranean Africa and the northern Sahara, with a greater likelihood of decreasing rainfall as the Mediterranean coast is approached.
- Rainfall in southern Africa is *likely* to decrease in much of the winter rainfall region and western margins.
- There is *likely* to be an increase in annual mean rainfall in East Africa.
- It is unclear how rainfall in the Sahel, the Guinean Coast and the southern Sahara will evolve.

Evidence from the IPCC suggests that areas of the Sahara are likely to emerge as the most vulnerable to climate change by 2100 with likely agricultural losses of between 2 and 7% of GDP. Western and Central Africa are expected to have losses ranging from 2 to 4% and Northern and Southern Africa are expected to have losses of 0.4 to 1.3% (Mendelsohn et al., 2000). Maize production is expected to decrease under possible increased ENSO conditions which are expected in southern Africa (Stige et al., 2006).

A South African study undertaken by the University of Pretoria and focusing at the provincial level, found a significant correlation between higher historical temperatures and reduced dryland staple production, and forecast a fall in netcrop revenues by as much as 90% by 2100. The study found small-scale farmers to be worst affected by the decrease.

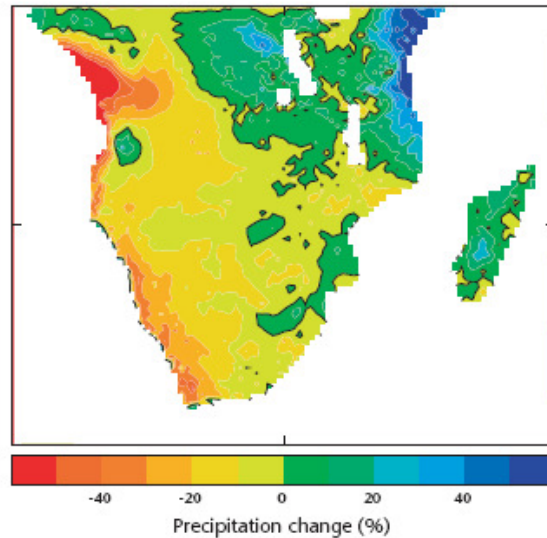

**Figure 5:** Change in mean summer rainfall over Africa for 2080, model output from PRECIS.

*Source:* PRECIS Handbook 2004.

A Nigerian study applied the EPIC crop model to give projections of crop yield in during the 21<sup>st</sup> century. The study modeled worst case climate change scenarios for maize, sorghum, rice, millet and cassava (Adejuwon, 2006). The indications from the projections are that, in general, there will be increases in crop yield across all low land ecological zones as the climate changes during the early parts of the 21<sup>st</sup> century. However, towards the end of the century, the rate of increase will tend to slow down. This could result in lower yields in the last quarter than in the third quarter of the century. The decreases in yield could be explained in terms of the very high temperatures which lie beyond the range of tolerance for the current crop varieties and cultivars.

An Egyptian study compared crop production under current climate conditions with those projected for 2050, and forecast a decrease in national production of many crops, ranging from -11% for rice to -28% for soybeans (Eid et al., 2006). Other potential impacts linked to agriculture include erosion that could be exacerbated by expected increased intensity of rainfall and the crop growth period that is expected to be reduced in some areas (Agoumi, 2003). Changes are also expected in the onset of the rainy season and the variability of dry spells (e.g., Reason et al., 2005).

Thornton et al., (2006) mapped climate vulnerability with a focus on the livestock sector. The areas they identified as being particularly prone to climate change impacts included arid-semiarid rangeland and the drier mixed agro-ecological zones across the continent, particularly in Southern Africa and the Sahel, and coastal systems in East Africa. An important point they raise is that macro-level analyses can hide local variability around often complex responses to climate change. Figure 6 shows two scenarios where >20% reduction in the length of the growing period is expected by 2050.

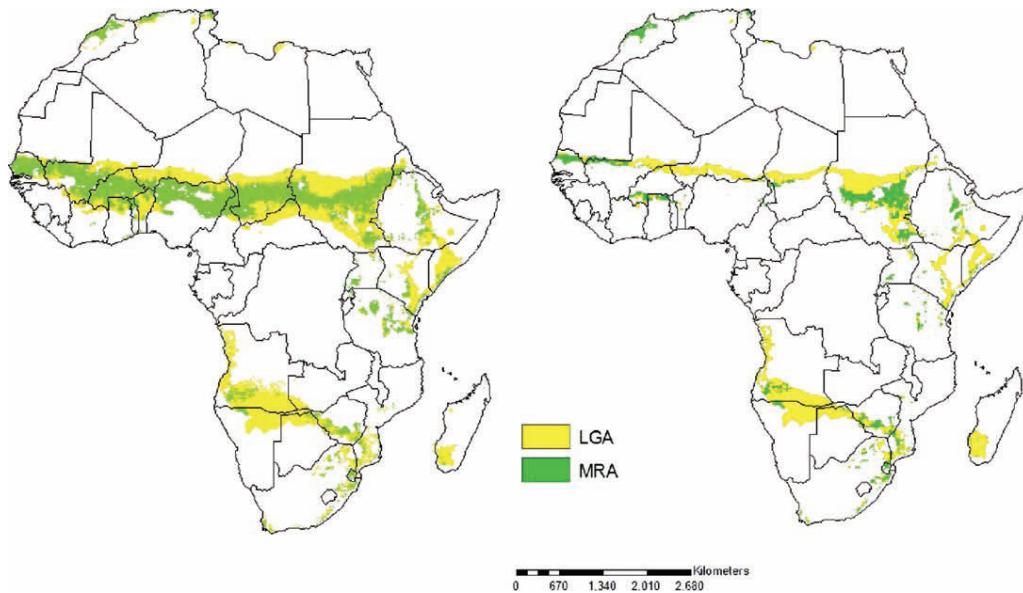

**Figure 6:** Agricultural areas within the livestock-only systems (LGA) in arid and semi-arid areas, and rain-fed mixed crop/livestock systems (MRA) in semi-arid areas, are projected by the HadCM3 GCM to undergo >20% reduction in length of growing period to 2050, SRES A1 (left) and B1 (right) emissions scenarios, From Boko et al (2007) after Thornton et al. (2006).

The International Livestock Research Institute in collaborate with Michigan State University have conducted a number of local studies aimed at understanding local variability and the complex interactions between local land use practices, local climate and human well being. The impacts of climate change on livestock are likely to be felt from an increased severity and frequency of drought. Deterioration of pastures during droughts, and periods of over-grazing can result in poor health and death of livestock, which impacts food and livelihood security of those who own livestock. In times of water scarcity, when livestock are forced to use the same water resources as humans, diseases are transferred between humans and animals and vice versa. Where livestock practices alter local vegetation cover, this in turn affects local climate (Olson, pers. comm.).

In northwest Kenya, recurring droughts have led to increased competition for grazing resources, livestock losses and conflict. Based on temperature and precipitation readings, Michigan State University have found no discernable trend in the frequency or intensity of droughts in the region, in spite of local farmers articulating a worsening situation. There is a suggestion that higher average temperatures have stressed the regions vegetation to the extent that it takes less extreme hot and dry spells to inflict drought like conditions.

### 3.3 Climate adaptation and agricultural development

Climate change adaptation aims to mitigate and develop appropriate coping measures to address the negative impacts of climate change on agriculture. Most agricultural systems have a measure of in-built adaptation capacity (“autonomous adaptation”) but the current rapid rate of climate change will impose new and potentially overwhelming pressures on existing adaptation capacity. This is particularly true given that the secondary changes induced by climate change are expected to undermine the ability of people and ecosystems to cope with, and recover from, extreme climate events and other natural hazards. It is for

this reason that the IPCC encourages “planned adaptation”, that is deliberate steps aimed at creating the capacity to cope with climate change impacts (IPCC, 2007).

Effective adaptation strategies and actions should aim to secure well-being in the face of climate variability, climate change and a wide variety of difficult to predict biophysical and social contingencies. In pursuing this aim, climate adaptation should focus on support for the decision-making and capacity building processes that shape social learning, technology transfer, innovation and development pathways. Adaptation is most relevant when it influences decisions that exist irrespective of climate change, but which have longer-term consequences (Stainforth et al., 2007).

A key component of climate adaptation involves building resilience, where resilience is the capacity of a system to tolerate disturbance without collapsing into a qualitatively different state that is controlled by a different set of processes: a resilient system can withstand shocks and rebuild itself when necessary.

Over sixty per cent of Africans remain directly dependent on agriculture and natural resources for their well-being (FAO, 2003). Agriculture is highly dependent on climate variability (Salinger et al., 2005) which is why the threat of climate change is particularly urgent in Africa (Boko et al, 2007).

Despite the reliance on large proportions of the population on agriculture, agricultural development has historically not been a priority of governments, with 1% or less of the average national budgets going to agriculture (FAO, 2003). However many donors and NGOs have supported agriculture across the continent because of this reliance on agriculture and the potential to improve yields. Alliance for a Green Revolution in Africa (AGRA) is an example of such an organization that is supporting agriculture development across the chain from funding projects on seeds and soils to markets and policies ([www.agra-alliance.org](http://www.agra-alliance.org)).

In spite of the documented exposure of agricultural activities to projected changes in climate, not all agricultural institutions have made use of climate science data. The current tendency is for institutions to reference climate change as a backdrop to their work as opposed to integrating probabilistic future climate data into their current planning and research approaches. Accordingly it is difficult to distinguish the documented cases of climate change adaptation in Africa from general development and agricultural practice. The impacts of the East African droughts, for example, have been countered in some instances by digging and maintaining sand dams in river bottoms. The dams allow for continued cattle watering during dry periods, and have reduced cattle deaths and conflict. It is not possible, however, to establish climate change as the trigger for the construction of sand dams (or other adaptation measures), and the people constructing sand dams do not draw on climate change data.

This apparent disconnect between adaptation efforts and climate data is in spite of efforts on behalf of climate scientists (including ACMAD, Tyndall Centre, AGRHYMET, Walker Institute and CSAG at the University of Cape Town) to make their work more relevant to

agriculture, and the equally concerted attempts by the impact community to clarify their climate information needs. Some interviewees attributed this situation to a lack of understanding among agriculturalists of how climate data can or should be applied. As Neil Leary from START suggested, most farming groups are naïve as to how difficult it is to understand, interpret and use climate information. It is equally true, however, that much of the climate modeling work remains focused on gaining greater understanding of atmospheric dynamics, and does not appreciate the type of issues confronted by farmers or the manner in which data needs to be packaged so as to make it accessible to agricultural decision makers.

As such agricultural adaptation that has always taken, and continues to take place in Africa, is responding more to perceived climate variability than climate change. This is true of the examples unearthed in this study, as well as the season forecasting and drought early warning systems that enjoy increasing use (especially among livestock farmers) on the continent. Very little has been accomplished in relating crop yield and animal productivity to climate change in Africa, even though the appropriate methodology is available in contemporary literature. Whilst these systems have proven their worth for farmers, there is a danger that farmers, agricultural policy makers, crop breeders and government officials that structure their activities around short term climate variability, will be exposed by the trend of climate change and its longer-term implications.

Three problems appear to impede the wider use climate data for farmers and agricultural decision makers. First, climate change data are not available at the spatial resolution required by farmers and as such farmers struggle to reconcile their observations of the weather with climate projections and lose confidence in the projections. Second, the timeframes (or temporal resolution) over which climate data are reported is often of little relevance to farmers. Whilst one might expect policy makers to consider the implications of a 2050 projection, farmers base their decision on more immediate issues. Third, there are very few African scientists with the requisite training and experience to interpret and apply climate change data in the agricultural context.

## Chapter 4: Institutions and programs active in African climate science and agricultural adaptation

The study required a mapping of the institutions and programs that are currently active in the field of African climate science, agricultural development and climate change adaptation.

This chapter draws on the database of institutions that was compiled at the inception of the report, the researchers' professional experience and the results of the forty-one interviews conducted by the researchers to provide an oversight of the key players and their programs.

The list of institutions and programs cited in this section is neither definitive nor exhaustive. It does however aim to identify and describe the key players and activities in the rapidly expanding field of climate science and agricultural development in Africa.

Once the interviews had been conducted, institutions were clustered according to their primary focus: climate science, climate adaptation and agricultural development, as well as in terms of their mandate: donors and development agencies, researchers and practitioners (see Table 2 below).

	Climate Science <sup>5</sup>	Climate Adaptation <sup>6</sup>	Agricultural Development <sup>7</sup>
<b>Donors and Development Agencies</b>		GTZ (Peterson, Lawrence)	
		SIDA (Palm, Mirjam)	
		USAID (Furlow, John)	
		DGIS (Pirenne, Christine)	
		DFID (Lennard Tedd, Sean Doolan)	DFID
<b>Researchers</b>	J.K University (Gathenya, J.: ACCCA project - Kenya).	Bodolo, M. (ACCCA project - Burkina Faso)	Molua, E. (ACCCA project Cameroon). Buea University; Dept. Economics.
	Iowa State University / Federal Univ. Technology, Akure/University of Cape Town (Babatunde Abiodun)	Kamaila, E. (ACCCA project Malawi).Zambian Red Cross Society	Lake Chad research institute (Bukar Bababe)
	Hewitson, B and Tadross, M. (University of Cape Town)	Boubacar Sidiki Dembele (Ministry of Environment and Sanitation, Mali)	University of Pretoria (Jame Blignaut)

<sup>5</sup> Climate Science: Stakeholders or organizations producing or using climate science in their respective areas of work.

<sup>6</sup> Climate adaptation: Stakeholders or organizations whose work incorporates or focuses on climate change adaptation.

<sup>7</sup> Agricultural development: stakeholders or organizations whose work focuses largely on agricultural development

	MSU (Jennifer Olsen) (linked to livestock)	CLIP and EACLIPSE (ILRI)	Centre for Arid Zones Study
	Wilby, R. SDSM	CCAA (Anthony Nyong)	IAR&T
	Tyndall Centre (Andrew Watkinson)	LEAD Network (Kenneth Gondwe)	International institute for tropical agriculture
	Walker Institute for Climate Systems research (Maria Noguera)	START (Neil Leary)	AGRA (Joe de Vries)
	GCOS (William Westermeyer)	Tom Downing, Stockholm Environment Institute	AERC (Olu Ajakaiye)
		IIASA (Anthony Patt)	CGIAR (Ann-Marie Izaac)
		Anderson, Simon (IIED)	ICRAF (Peter Cooper, Louis Verchot)
<b>Practitioners</b>	Overseas Mwangase, Chief Meteorologist (Zambia Meteorological Services)	Adele Arendse (SSN Africa)	ALMP (James Oduor)
	ICPAC (Chris Oludhe; Bwango Apuuli)	SSN Group	Jabenzi (James Blignaut)
	ACMAD		World Vision (Joe Muwonge)
	Nigeria Ministry of Environment (Special climate change unit) (S.A Adejuwon)		FAO (Climate Change working group)
			AGRHYMET
			FEWSNET

**Table 2:** Interviewees for project

*Note:* White: national activities based within African countries, Green: regional activities, based in Africa, Blue: internationally based

From this table it is evident that the study focused on the specific donors addressing climate change adaptation. Interestingly these donors are all internationally based, as are the majority of climate scientists. The national climate science activity that is taking place is linked to organizations such as ACMAD and ICPAC. In the table we have classified much of this activity under “practitioners” as it tends to be linked to public services. One of the findings emerging from the study that is reflected in the table is the lack of adaptation specific practitioners. There are practitioners in the agricultural sector who are exploring climate change impacts, and there are climate scientists focusing on adaptation. There is noteworthy lack of practitioners with knowledge of both climate change and agricultural adaptation.

#### 4.1 Donors involved in climate science and agricultural adaptation

It is clear that adaptation is becoming more widely supported among donors. Increased support for adaptation is coming from traditional development donors who see the need to protect the benefits of their program and projects against climate change, as well as some donors that see climate change adaptation as a goal in itself.

Government agencies are scaling up their adaptation commitment and the number of people assigned to work on adaptation is growing. For example, GTZ have 10 people working on climate change with 2 dedicated to adaptation issues, USAID have 5 people working on climate change issues, with 2 of those focused on adaptation and SIDA are just



starting to grow their adaptation focus. The World Bank has 15 people in its climate change group, 9 of whom work on adaptation globally. FAO, similarly, have launched a well attended Inter-departmental Working Group on Climate Change, with a specific adaptation focus.

**Department for International Development (DfID)** integrate climate change adaptation into their Central Policy Research Division, the work of their country offices and into their pan-African program. DfID do not fund climate change models, but do have a number of programs focusing on rural economies in Africa.

In terms of its funding allocations, DfID's lead adaptation program is the Climate Change Adaptation in Africa (CCAA) program. The £24 million program is funded jointly by DFID's research division and IDRC (Canada). "The CCAA program works to establish a self-sustained skilled body of expertise in Africa to enhance the ability of African countries to adapt." CCAA makes use of a variety of climate and weather data use to inform its adaptation support. In Benin, for example, farmers in the CCAA program received access to a "weather pre-alert" system, but did not make use of medium term or long term climate forecasts. In the Western Cape of South, fruit farmers in the CCAA program did get the benefit of GCM forecasts from the Hadley Centre to assist them in anticipating water availability scenarios, but these models were at a continental scale.

In order to protect this portfolio of projects against climate change DfID has undertaken an internal due diligence study aimed at identifying risks created by climate change for their existing and proposed work. The study relied on PRECIS to gain an idea of future climate related risks in Africa and, somewhat surprisingly given the number of agricultural and water projects that DfID supports in Africa, concluded that risks to DfID work were generally quite low on the grounds that their poverty alleviation efforts contributed to climate coping capacity. DGIS and DANIDA have conducted similar "climate screening" exercises on their activities; their conclusions were less optimistic.

**International Development Research Centre (IDRC)** has partnered with the Department for International Development (DFID) to fund The Climate Change Adaptation in Africa (CCAA) is a 5-year program which started in 2006. The program is currently funding 14 projects in Africa with a budget of £24 million. The main aim of CCAA is to improve the capacity of African people and institutions to adapt to climate change in ways that benefit the most vulnerable. In order to do so, the CCAA supports a range of activities that build research capacity and provide evidence to strengthen adaptation policies and plans.

There are various ways in which the program is trying to increase the engagement of stakeholders and improve the communication of climate information. Firstly, an action research approach is taken on adaptation which links communities, researchers, development agents and policymakers in a shared process of testing new and existing adaptation strategies. Furthermore, the CCAA supports a learning-by-doing approach as well as a range of communication and dissemination activities to see knowledge on adaptive practice shared widely. Finally, monitoring and evaluation of the program takes

place on the basis of ‘outcome mapping’, a tool developed by IDRC to assess changes in behavior, actions and activities of the people who are directly involved in the project.

Both the ACCCA and CCAA are linked through joint UNITAR management of the two programmes with ENDA as regional partner. The two are increasingly moving towards the development of more specific and concrete adaptation measures by working closely together with stakeholders and policymakers and by increasing the applicability and relevance of climate change information. There are a handful of CCAA projects that are linked to ACCCA through the support of ENDA-TM.

**The Global Environment Facility (GEF)** is a collaboration between UNEP, the World Bank and UNDP, GEF is an independent financial organization that provides grants to developing countries for projects that benefit the global environment and promote sustainable livelihoods in local communities. Assessments of Impacts and Adaptations to Climate Change (AIACC), was one of GEF’s key initial adaptation programs. AIACC consisted of a global initiative developed in collaboration with the UNEP/WMO Intergovernmental Panel on Climate Change (IPCC) and funded primarily by the Global Environment Facility (GEF) to advance scientific understanding of climate change vulnerabilities and adaptation options in developing countries. The total budget was around \$8 million (with \$7.5 million from the GEF, \$300 000 from USAID, \$100 000 from CIDA, \$50 000 from USEPA and \$25 000 from Rockefeller, plus about \$20K in-kind services and co-financing by the AIACC partners reported at \$1.8 million). The program started in 2002 and the final reports were submitted in 2006. Similar to the NCCSAP, the AIACC program took an approach to capacity building that was research driven. Twenty-four regional assessments were carried out under the AIACC program, covering 46 countries. Seventeen of the countries were in Africa.

The AIACC regional studies were diverse in their objectives, scientific methods, and in the sectors and systems that were investigated. These include, among others, food security, water resources, livelihood security, and human health. Despite this diversity, the studies share a common assessment approach that places understanding vulnerability at the center of the assessment.

Even though the program’s initial focus was on enhancing the scientific capacity of developing countries, the program also sought to take the state of the assessments one step further and make the research more relevant to local and regional priorities by engaging stakeholders in the assessment process. The end result is that, to some extent, the AIACC climate change assessments did engage effectively with policy processes. At the same time, however, the final report does recognize the need for the further engagement of stakeholders in the design and start up phases of the projects.

The association of poverty and low levels of development with high levels of vulnerability is borne out in the AIACC studies. Failures of development to raise people out of poverty has resulted in people occupying highly marginal lands for farming and grazing, settling in areas susceptible to floods and mudslides, and living with precarious access to water, health care and other services. These conditions contribute to the high degree of vulnerability

found among the rural poor, as shown in the AIACC case studies in Botswana, Nigeria, Sudan, Thailand, Lao PDR, Vietnam, the Philippines, Argentina and Mexico (Leary et al. 2008). Some urban squatter communities in Jamaica and the Philippines are more vulnerable than other communities because of lack infrastructure, access to basic services and social institutions to support collective efforts for reducing risks (Taylor et al., 2007, Lasco et al., 2007).

**DGIS (Netherlands Ministry of Foreign Affairs/Directorate General for International Cooperation):** In recognition of the need to assist developing countries to adapt to the adverse effects of climate change, DGIS launched the Netherlands Climate Change Studies Assistance Program (NCCSAP) in 1996. Being one of the first climate adaptation programs, the first phase of NCCSAP focused on creating a greater awareness of climate change issues and building capacity among scientists and policymakers. The program was active in 13 countries, including 5 countries in Africa.

The program put emphasis on the identification and quantification of impacts, especially in the agricultural and water sector. In many of the country studies, mathematical models were used to model possible future impacts of climate change on the agricultural and water sector based on IPCC scenario outcomes. In the evaluation of the program, it was recognized that the translation of the model outcomes into something useful for policymakers remained problematic. According to the evaluators this was due to an inability among the technical experts to effectively communicate the study results to the stakeholders and to a lack of involvement of stakeholders in the early phases of the program. Despite these shortcomings, the program did increase the capacity of scientists and experts from the participating countries in understanding the impacts of climate change in their respective countries.

In a follow up to the first phase of the NCCSAP, the Netherlands Ministry of Foreign Affairs/Directorate General for International Cooperation (DGIS) initiated a second phase of the NCCSAP starting in 2003. Similar to the first phase, the second phase, which is called NCAP, also aims to increase the capacity of developing countries to deal with the adverse effects of climate change. However, whereas in the first phase the focus was predominantly on understanding the biophysical impacts of climate change, the NCAP phase puts more emphasis on understanding the vulnerabilities of people and livelihoods and tries to influence policy processes. As such, the second phase of the program started to move away from a unilateral focus on research. To stress this shift in focus, the name of the program was changed to Netherlands Climate Assistance Programme.

The NCAP is active in 14 countries, including 5 countries in Africa. The topics and approaches taken by the different country projects are much more diverse than during the first phase, including water, health, agriculture and coastal zone management. The program will end in June 2008.

Even though the NCAP and AIACC Programs have taken important steps to engage stakeholders and influence policymaking processes, considerable challenges have remained in translating the results into something that is useful and applicable for policymakers and

decision-takers. These challenges relate to the uncertainty that is inherent in climate change projection data, the scale at which they are available and the relative lack of skills among climate change experts to communicate the information to stakeholders. More recently, two international research programs have been launched by DGIS which, among other things, try to address these challenges.

Both GTZ and USAID referred to support material they were developing in order to help a range of stakeholders interpret and use climate data (although neither of them is publicly available yet). These included 'recipe books' of where to access climate information, assess the quality of information and develop risk management strategies as well as manuals that intend to take users through a process of using climate change projections to map impacts. There is also the recognition of the need to improve capacity on communicating climate information and applying available climate information to responses.

Although START is not a donor, they manage a number of donor programs that relate to climate change. Neil Leary of START highlighted a concern that many development donors are supporting floods, famine and conflict disaster response, and do not see it as their responsibility to support longer term research on climate science and adaptation, even though this research could assist them in their preparation for disasters. At the same time, many science agencies do not fund adaptation on the grounds that this will be covered by development donors. These leaves something of a gap in the available for funding for programs focused specifically on climate change adaptation. As Neil Leary observed, "It is important to adapt now but this should be supported by science", which requires science agencies and donors to cooperate more.

This observation was born out by this study. Whilst climate scientists were generally adequately funded, and traditional development agencies were all aware of climate change, there were very few programs (CGIAR have requested funding for a program and MSU's CLIP program draws on local climate science) specifically focused on linking climate science with adaptation efforts. Instead most current donor activity aimed to either assess impacts and vulnerability to climate change in order to determine priorities, or integrate a measure of "climate proofing"<sup>8</sup> in development projects.

Interestingly, amongst the donors interviewed, agriculture was not always the main focus. GTZ acknowledged that there has been a move away from focusing on agriculture to rather focusing on issues around nutrition, food quality and getting to market. SIDA is exploring how adaptation to climate change can be integrated into poverty alleviation approaches within different sectors. USAID has supported some agricultural-focused activities and explored what additional challenges climate change may present. DFID maintains an agricultural focus in East and Southern Africa but at the request of West African governments has moved its focus in that region to urban issues.

---

<sup>8</sup> "Climate proofing" whilst in common use in the development discourse, is not a term that the authors support on the grounds that it is very difficult to predict all climate change impacts and then secure projects and programs against climate change. Whilst most development institutions recognise this, the term endures. "Climate preparedness" might be more appropriate.

To some extent the gap in funding for adaptation specific activities is being filled by private sector funders. There has been a discernible increase in private sector funding for development and climate change activity. In the past five years the activities of the Bill and Melinda Gates Foundation, the Google Foundation and the Rockefeller Foundation (to name but a few) have moved beyond conventional corporate social responsibility and begun to engage systemically with global issues. This has seen an increasing overlap with the work of traditional donors such as DfID, USAID, SIDA and GTZ, but private sector funders appear to have identified the specific need for climate change adaptation in advance of the traditional donors.

Interviewees at DFID welcomed the involvement of large private sector players and cited the relative flexibility, speed of mobilisation and innovation that they could contribute. However, **in the field of climate adaptation there is not yet a clear division of labor and responsibilities between private donors and their more traditional public sector counterparts.**

#### 4.2 Key research institutions

Since the ratification of the United Nations Framework Convention on Climate Change, various international research programs have been undertaken in order to develop the capacity of developing countries to cope with the effects of climate change. Typically, these research programs are a collaborative effort of many different institutions involving research institutes, NGO's as well as governmental institutions. Many times, these international research programs also involve studies on the impacts of climate change on the agricultural sector.

Even though it is hard to generalize about the different programs, a shift seems to have taken place in the past 18 months, from a primary focus on understanding the nature of climate change towards the question about who is vulnerable and why. More recently, a further shift is taking place towards an increased attention for policy-relevant applications and the question on how to adapt. To some extent, these shifts are in line with the current developments in the climate change debate which has gradually moved from a focus on awareness raising about the reality of the problem towards a focus on how to respond.

Interestingly most of these institutions are reliant on financial and other support from non-African sources, and as such there are very few "home-grown", locally funded research programs focused on climate adaptation in Africa.

**IPCC and supporting research institutions:** The intergovernmental panel on climate change (IPCC) is the preeminent source of climate change information. The IPCC reviews and collates research on a range of climate change related issues and records climate data in its data distribution centre (DDC).

No African climate research institutions are involved in producing GCM models. Because of the lack of the necessary tools, both human and instrumental, Africa depends, to a very large extent, on institutions based in Europe and North America for its operational climate

forecasting capacity. Three institutions - NOAA (National Oceanic and Atmospheric Administration, USA), UK Met Office/ Hadley Centre (United Kingdom) and CNRS (Centre National de la Recherche Scientifique, France) routinely make seasonal climate forecasts for Africa based on their respective GCM models.

Among these three it is clear that the Hadley Centre, and specifically their dynamically downscaled PRECIS model, is the most widely applied, especially in Southern Africa.

**CSAG** (Climate Systems Analysis Group) at University of Cape Town (UCT) is the only African institution currently engaged in empirical downscaling activities for climate change. In the last 6 months CSAG has made available downscaled data from 6 GCM AR4 (IPCC Fourth Assessment Report) models. The implication is that there is downscaled daily control period data and climate projection data for multiple scenarios extending from 2050 until 2100 for the whole of Africa from 6 different GCMs. These data are available through the CSAG website that requires registration but no charge.

The CSAG model enables users to compare outputs from the entire archive of IPCC models, rather than relying on a single model's projections. In spite of attempts to make it accessible, the uptake of CSAG's downscaled data has, to date, been fairly limited.

**ACMAD** (Africa Centre for Meteorological Applications for Development), based in Niamey, Niger, is charged with gathering, collating and disseminating weather forecast information. ACMAD operates in synergy and in a network with international partners, partner institutions and focal points. The international partners include: France's CNRS, United Kingdom Met Office and United States NOAA among others. These institutions provide the primary climate information to be collated and transmitted to the end users within the various African countries. The partner institutions have specific sector and regional responsibilities which require weather and climate information. Among such institutions are AGRHYMET and ICRISAT. The primary focal points are the National Meteorological Services of 53 African Countries. Focal points for ACMAD have also been established within the operational structure of sub-regional economic groupings such as ECOWAS (Economic Community of West African States) and SADC (South Africa Development Community). The focal points are the primary recipients of the products emanating from ACMAD, meant for end users in agriculture, energy, water resources and other sectors within the various countries.

The data reception at ACMAD is achieved via a unique African Meteorological Environmental Diagnostic Integrated System (AMEDIS). AMEDIS is a system for receiving, processing and broadcasting meteorological information. It also consists of the Display Units, SYNERGIE and MESSIR-VISION. SYNERGIE is a forecast tool (software suitable for universal applications) for an easy and efficient access to a wide range of observed and predicted meteorological data. It is versatile and adaptable to specific situations and also further developments. The MESSIR-VISION is comparatively less expensive and is operational on PC. ACMAD is thus not yet qualified to conclusively interpret the climate predictions from the model products. Climate prediction and weather forecasting consist of complex and interactive processes on various scales of motion, even

smaller than considered on the GCMs. The degree of importance of the smaller-scale circulation varies from one sub-region to the other. Thus the need for regional modeling and downscaling of GCM outputs is yet to be adequately met from within Africa.

**IGAD Climate Prediction and Application Centre (ICPAC):** ICPAC is a regional climate centre based in Nairobi, Kenya. The Centre was established in 1989 as the Drought Monitoring Centre in Nairobi (DMCN) in an effort to minimize the negative impacts of extreme climate events like droughts and floods in the Greater Horn of Africa. In recognition of the role of the Drought Monitoring Centre in the region, the IGAD (Intergovernmental Authority on Development) Heads of State and Government, decided to absorb DMCN as an autonomous specialized institution of IGAD. Hence, its name was changed to the IGAD Climate Prediction and Application Centre.

The major goal of ICPAC is to improve and enhance the production and provision of sector-relevant climate information and applications in the IGAD region. To that end, ICPAC is producing decadal (10 day), monthly and seasonal forecasts and distributes them to all National Meteorological and Hydrological Services of the participating countries, as well as to sectoral users, including policy makers and planners in the health, energy, agriculture and water sectors.

Whereas the focus of the centre is primarily on the production of information about climate variability, ICPAC has recently also started to work on generating climate change projection data, mainly through the use of the PRECIS dynamical downscaling model. In October 2007, they organized a training workshop on PRECIS for all National Meteorological and Hydrological Services (as well as some universities) in the region. The training was funded and supported by the Hadley Centre and the International Centre on Theoretical Physics (ICTP). In the near future, ICPAC intends to expand its activities and services in the field of climate change and relationships have already been established with the Climate for Development in Africa Program.

One of the flagship activities of ICPAC is the organization of the Climate Outlook Forums that take place twice a year. During the Climate Outlook Forums, ICPAC presents the most recent seasonal forecast and discussions can take place between climate scientists and sectoral decision makers to assess and evaluate the usefulness and applicability of the information that is provided by ICPAC. So far, ICPAC has organised 17 Climate Outlook Forums.

**Global Climate Observing System (GCOS):** In 2005, DFID and Defra jointly commissioned a review of Africa's science gap, and measures needed to reduce it, ahead of the UK Presidency of the G8. The report showed that we know remarkably little about Africa's climate. Furthermore, the African climate observing system is the least developed of any continent and is deteriorating. Scientific understanding of the African climate system is, as a whole, low. The level of technical expertise available to support climate science in Africa, and hence the level of activity, is very low (Wilby, 2007: 3).

**CGIAR:** CGIAR with a secretariat in Washington, has an exclusive agriculture (including forestry, fisheries, aquaculture, water management) focus, and the bulk of CGIAR's climate change work is focused on Africa. CGIAR are about to launch a major Challenge program aimed at integrating climate science. CGIAR recently submitted a proposal for a 10 year study that will seek to close the gap between existing climate data at the regional level (from the World Climate Research Programme, WCPR) and existing data that is available for land-use and socio-economic change at the local level.

The proposal outlines 3 study sites initially, two of which will be in Africa (i) Eastern and Sub-Saharan Africa (ii) Central and Western Africa. With regards to the human capacity that it will mobilize, the proposed CGIAR study will draw on 5-6 researchers in each of CGIAR's 15 centres.

**The United Nations Food and Agriculture Organization:** FAO in Rome has a widespread presence in Africa. FAO's overarching mandate is the support of food security in Member Countries, but the organization undertakes a range of activities and recently launched a climate change adaptation strategy aimed primarily at focusing the relevant units and their efforts within the organization, but also at signaling internationally FAO's intent to engage in climate change adaptation. FAO has access to a wealth of agri-met data but does not specifically apply climate change projections in its agricultural support programs.

**ICRISAT:** ICRISAT has used regional IPCC data to explore the impact of a 3 degree warming on a variety of crops. Some of these (IPCC) data are obtained from the download options available in the DDC (Data Distribution Centre).

**Iowa State University:** Over the last 7 years, Iowa State University's College of Liberal Arts and Sciences has been developing (and applying) a regional climate change model called the CAM-EULAG model. CAM-EULAG is a downscaling model which uses the grid adaptive model which is based on the use of global models. The model has been used in the USA to study hurricanes over the Atlantic Ocean. Babatunde Abiodun, a Nigerian post doctoral researcher has been working with the team for the past 3 years and is currently looking into adopting the model for use in Southern and Western Africa. From 2008 he will be based part-time at CSAG at the University of Cape Town and work in collaboration with them and in partnership with the Federal University of Technology in Akure, Nigeria. Using climate change simulations, Babatunde hopes to see the impacts on crops and water resources. The output data from the model will be useful for agricultural development because farmers usually need to know when to start planting. Therefore, based on the crop type, specific crop models can be produced as these are useful in understanding what the expected yields of a particular crop can be. The model can also be used for seasonal forecasting - usually over a period of 3 months.

**SEI:** Stockholm Environment Institute specializes in sustainable development and environment issues at local, national, regional and global policy levels over its 6 centers around the world. The SEI Oxford center in particular focuses on adaptive resource management, particularly related to climatic risks, with expertise in water, food security and livelihoods. Over the years the center has been involved in African agriculture through



numerous projects. One of the center's current initiatives is developing a collaborative platform for climate adaptation, called [weADAPT](#), and building a network of Centers for Climate Adaptation in Africa. This involves developing novel approaches to link risk of future climate change, viewed within a multi-stressor context, to robust adaptation actions.

**START International:** Global Change SysTEm for Analysis, Research and Training research activities in Africa are consistent with critical environmental priorities in the continent which include food and water security and vulnerability to climate change impacts. START fosters regional networks of collaborating scientists and institutions in developing countries to conduct research on regional aspects of environmental change, assess impacts and vulnerabilities to such changes, and provide information to policy-makers. START also provides a wide variety of training and career development opportunities for young scientists.

**NCAR:** The National Center for Atmospheric research (NCAR) has used the MAGICC/Scengen software package for future climate change prediction and particularly drawing out the sources and magnitude of uncertainty (see Wigley, T. 2004). Boulder University are responsible for the MAGICC/SCENGEN model (currently in version 2.4), based on DOEPCM GCM. The downscaled climate model applies a regionalization algorithm. It takes emissions scenarios for greenhouse gases, reactive gases, and sulfur dioxide as input and gives global-mean temperature, sea level rise, and regional climate as output. The software also quantifies uncertainties in these outputs. The regional results of the model are based on results from 17 coupled atmosphere-ocean general circulation models (AOGCMs), which can be used individually or in any user-defined combination (Hulme, et al., 2000).

**Michigan State University:** MSU's Department of Telecommunications, Informational Studies and Media, Michigan State University has a longstanding partnership with the International Livestock Research Institute, Kenya. ILRI and MSU conduct several joint programs in East Africa looking at local interactions of land use and climate.

MSU's flagship adaptation project is called CLIP. Whereas many programs are increasingly focusing on policy applications there are a couple of programs that continue to focus on unraveling the complexities of the climate system and the ways in which it is interacting with the biophysical environment. One such program is the Climate-Land Interaction Program (CLIP).

The CLIP project has developed a unique coupled modeling system integrating human behavior and biophysical factors that traces current and future land and climate change in East Africa. The framework allows geographically explicit analyses of the impacts of land use and climate change on natural and agricultural systems. Components include a regional climate model for East Africa linked to a dynamic crop-climate model and to a land use change model. The system projects climate changes between 2000 and 2050 and includes intra-daily, seasonal and yearly trends of many climatic variables.

The CLIP system can be used to explore in more depth agricultural productivity as related to climatological and soil constraints, as well as technological changes (e.g., crop variety characteristics, fertilizer applications). As such the system allows to explore how technological advances could be developed to better respond to recent and projected climate changes.

**University of Pretoria:** James Blignaut at the University of Pretoria's Economic Department has conducted his own research on the relationship between historical temperature and rainfall and agricultural productivity in South Africa. The research makes no use of global or regional climate projections. The Centre for Environmental Economics and Policy in Africa (CEEPA) located within the Department of Agricultural economics, Extension and Rural Development at the University of Pretoria has been running a project over the past few years that aims to improve national and regional assessments of the economic impact of climate change on the agricultural sector of eleven African countries, and to determine the economic value of various adaptation options. The budget was US \$ 1.32 million over 3 years.

#### 4.3 Key practitioner institutions involved in climate adaptation

Institutions involved in actual adaptation initiatives appear to be fewer than those involved in research, but a number of agricultural programs have designed adaptation components.

UNITAR is managing the implementation of the ACCCA programme with the scientific support of a network of partners including the START International secretariat, TEA and SEA START, CSAG, SEI and ENDA TM. The ACCCA programme is funded by the European Commission, UK DEFRA, the Dutch NCAP through the ETC Foundation and the International Development Research Center (IDRC). ACCCA seeks to enable and support effective adaptation decisions that reduce vulnerability to climate change and environmental change. The program is funding 19 country projects, 14 of which are situated in Africa. At the start of the project in 2006 € 2,000,000 was available and more funding has been secured since then.

Building upon past experiences, the program emphasizes the importance of developing strategies for communicating climate risk information in a way that is clear and understandable for policymakers. Specific training modules have been developed to support the project teams in developing such communication strategies. In addition, the program is also working closely together with the Climate System Analysis Group at the University of Cape Town to provide the country teams with downscaled data for carrying out their vulnerability analyses.

**CLIMDEV:** The Climate for Development in Africa Programme (ClimDev) is currently still in the proposal phase. Building on the GCOS Regional Workshop Program and a follow up meeting in Addis Ababa in 2006, ClimDev Africa emerged as an African development program to integrate climate information into development practices. The objective of the Programme is to improve the availability, exchange, and use of climate information and services in support of economic growth and achievement of the MDGs, working at national, local and regional levels. This will be achieved by improving climate

observing networks and services in Africa and by taking actions necessary to improve climate-sensitive sectoral planning (including the agricultural sector) and decision-making at different timescales through adoption and implementation of climate risk management practices. It is envisaged as a 3-phase program over an 11-year period.

In order to strengthen resilience to short-term climate variability and long-term climate change, ClimDev-Africa will assess primary stakeholder needs in relation to climate information and build capacity in institutions (public, private and civil) and people to use climate knowledge more effectively in planning and decision-making. At the same time it will build capacity in the African national meteorological and hydrological services (NMHSs) and regional climate institutions to improve the quality and quantity of climate observations and to enhance the climate information services required for adaptation to climate variability and change.

The development of the Programme has gotten off to a slow start but recently substantial progress has been made in preparing programme documentation. There a number of prospective donors that are planning to help support the programme. In the period before resources become available, the principal African partners (AU, ECE, and ADB) plan to appoint an interim director who will be responsible for day-to-day startup and implementation activities. Although ultimate needs on a continental basis have been estimated to exceed \$800 million over ten or more years, the partners hope to raise about a tenth of this figure for activities in the first few years. The observations component of the programme (i.e., improving observing systems for climate), is estimated at about \$70 million.

**FAO** has conducted pilot studies in a number of member countries, typically with local ministries of agriculture. The pilots have various aims, but broadly seek to combine better use of information with improved technology and greater care for the natural environment, so as to deliver enhanced and less risky agricultural production. Whilst FAO pilots are beginning to consider the implications of climate change they do not make systematic use of downscaled climate data in their planning.

**SouthSouthNorth (SSN)** operates both as a local NGO (SSN Africa) and as an international network (SSN group) with a central office in Cape Town, South Africa. SSN started in 1999 with a focus on climate change issues and is now in the second phase of a 4-year cycle funded by the Dutch that ends at the end of 2008. The budget for all SSN work including adaptation is approximately \$4 million. They draw on climate change projections by engaging with climate scientists but they are only now starting to see how this information could be more strategically factored in to adaptation planning. One of their adaptation projects in South Africa focuses on how seasonal climate forecast information can be used by smallholder rooibos tea farmers and the potential agricultural strategies that could reduce drought risk (Archer et al., 2008).

Other stakeholders that fall under this category but not outlined in detail include World Vision, ENDA-TM, ALMP, AGRHYMET and FEWSNET.

In addition there are a number of private sector consultancies that are now active in the field of climate change adaptation, and some NGOs now sell their services in this field alongside consultancies on a wide range of matters including social learning, emissions management and trading, bioenergy and capacity building. Examples include OneWorld Sustainable Investments, Environmental Resource Management (ERM) and D1 oils. In the course of the interviews the researchers were referred to a local consultancy Jabenzi, which is affiliated to the University of Pretoria (James Blygnaut). The company is active in South Africa with a number of projects, and purports to restore natural capital so as to protect livelihood and commercial farming activities against climate change. The company does not base its activities on any specific climate data, but rather on an understanding of the general phenomenon.

#### 4.4 Producers and users of climate projection data in Africa

The section above has described institutions and where possible the climate data on which they rely. Figure 7 below illustrates the relationship between a select number of interviewees and the key climate models. This figure is not exhaustive but rather tries to capture some of the salient relationships. Noteworthy is the reliance by a large number of end users on relatively few models, often models that provide data at a highly aggregated spatial scale.

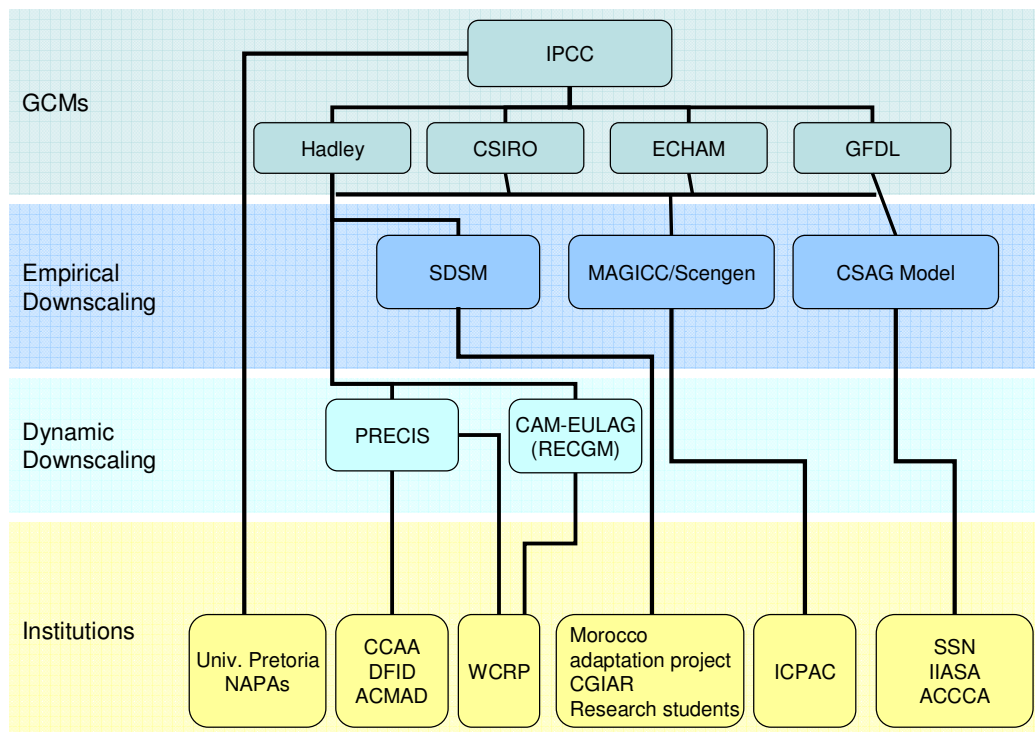

**Figure 7:** Producers and users of climate projection data in Africa.

## Chapter 5: Key Findings

### 5.1 The context of climate change adaptation in Africa

An important constraint to the effective adoption of climate change information in Africa's agricultural sector is the lack of a comprehensive baseline understanding that characterizes much of the current work. This lack of context manifests itself in three ways.

First, there appears to be a general tendency to isolate the impacts of climate change from the broader context in which developments are taking place. There are several examples where climate change is assumed to be causing negative trends without considering the possible importance of other drivers. Peter Cooper from ICRISAT, for instance, noted an example from the Machakos district in Kenya, where farmers blamed climate change and decreasing rainfall for decreasing crop yields. After consulting the meteorological records, however, it became apparent that rainfall had been increasing rather than decreasing. It was only after studying the broader context in more detail that it became clear that declines in crop yields were attributable, in large part at least, to a government decision that reduced fertilizer subsidies. In a similar way, many interviewees cited an increasing tendency among pastoralists to ascribe climate change as the principal cause for a reduced availability of pasture land. In doing so, however, pastoralists opt to downplay the detrimental effects of overgrazing on pasture resources. What these examples clearly illustrate is the importance of putting climate change in a broader context, taking into consideration other possible (and often more directly probable) causes and explanations. Lack of understanding of these other drivers of change might unintentionally lead to misdirected projects and, in the long run, to maladaptation.

Secondly, respondents from both SEI and START highlighted the tendency for institutions to adopt the adaptation mandate without first clearly understanding the climate change and vulnerability context. Institutions tend to take certain climate impacts and vulnerabilities for granted without looking at or even broadly understanding which climate parameters and conditions are actually responsible for specific vulnerabilities to climate change (versus vulnerability to a range of other stressors including health, conflict, and governance, among others) and how these parameters and conditions might change under future scenarios. This might again lead to misdirected adaptation measures.

Thirdly, climate change adaptation efforts often fail to contextualize climate change risks within the set of other climate information used in decision making, including historical data, real-time data and traditional knowledge, all of which are currently used and available to support decision making processes. In fact, there seems to be an apparent tension between people working on future climate change and those focusing on current climate variability. Climate change professionals tend to argue that by focusing on current climate variability, agricultural decision makers might be caught off-guard by climate change, particularly where the changes brought about by climate change are significant and can be abrupt. In modeling parlance this is referred to as responding to the climate change “signal” rather than the climate variability “noise”. In contrast, those who focus on climate variability claim that, unless farmers in Africa can be helped cope better with current

climate variability, the challenge of adapting to future climate change will be daunting for most and impossible for many.

It is clear that both views are important. These are not mutually exclusive perspectives and must be integrated in a seamless continuum. Both information about future climate change and information about current climate variability should be placed within the broader context of climate information in general and the value of each will depend on the specific decision-making context. A small-scale farmer, for instance, will be more interested in getting information about the expected rainfall in the coming season in order to make a decision on what crop to grow. In this case, seasonal climate forecasts are the appropriate resource (Ziervogel et al., 2006), and it should be unsurprising that these farmers do not prioritize climate change projections in their decision making. A crop breeder, on the other hand, might benefit more from an understanding of climate change patterns in the next 20 to 30 years because of the time delay between the development of new crops and the actual distribution and use. In this case an understanding of climate change scenarios would be beneficial. Similarly a donor agency looking to promote sustainable rural development should be interested in the climate change induced shifts in agro-ecological zones over a 10 to 20 year period.

Over the past couple of years, climate change professionals have increasingly acknowledged the importance of placing adaptation and the use of climate change information in this broader context of other drivers and have paid more and more attention to the local situation (Reid and Vogel, 2006; Ziervogel and Taylor, 2008). Nevertheless, the past and current experiences of interviewees still point to the fact that contextualizing climate change adaptation remains an issue of concern.

## **5.2 The state of climate change science in Africa**

The last 10 years have seen considerable advances in the global science of climate change modeling. This is attributable in part to an improved understanding of the physical processes governing the climate system as well as significant improvements in computational capacity. These advances in climate change have improved the number, quality and availability of GCM scenarios, with a few of direct relevance to Africa. The GCM data are provided mostly by international organizations in the North. These include the UK Met Office's Hadley Centre, NOAA (National Oceanic and Atmospheric Administration, USA) and CNRS (Centre National de la Recherche Scientifique, France) that all provide GCM data for Africa.

More important than the increased availability of GCM data, recent years have also seen an increase in downscaling efforts, both dynamic and empirical, providing information at a finer scale that, relative to the data produced by GCMs, is more relevant for research and policymaking. This is because downscaled data, when analyzed appropriately, can provide station level responses from GCM patterns, improving the temporal and spatial resolution of available information.

In Africa, however, the number of available downscaled datasets remains limited (especially when compared to those available for Europe and North America) and they are the product of an even more limited number of institutions and models. In fact the only African institution that is generating empirically downscaled climate data based on the IPCC's Fourth Assessment Report is CSAG at the University of Cape Town, but the application and assessment of the utility of these data remains limited. Instead, many researchers and practitioners continue to rely on output from a regional climate model, PRECIS a dynamical model developed by the Hadley centre.

Another common trend in Africa is that most climate modelers tend to rely on only one model output for their analysis, be it a GCM or a downscaled model. However, reliance on a single model makes interpretation of the data vulnerable to errors and less robust than multiple model approaches that permit comparison of results from different models. Here again, CSAG remains the only institution in Africa that is using a multi-model approach. The results from CSAG's downscaling efforts, which have been available online since late-2007, are based on 6 different GCMs, with more models continually added. This approach is rapidly proving a valuable avenue for the exploring the climatological boundaries (envelope) of climate scenario output, and represents some of the most detailed climate data available for Africa.

While the barriers to expanding the number of downscaled climate change projections and multi-model approaches in Africa are many, climate change modelers stressed the following two.

Firstly, one of the main barriers to producing climate change information remains the lack of reliable meteorological data. This is especially true for complex environments where higher concentrations station data are needed to capture the complexity of the terrain. While many African countries established extensive monitoring networks during much of the 20th century to support daily weather forecasting, economic difficulties in the region, not to mention civil wars, have led to the deterioration of these networks in recent years. In fact, there are fewer rainfall monitoring stations in many African countries now than there were 20 or 30 years ago (Patt, 2007). Ultimately, the lack of sufficient and clean historical data renders the task of developing sound and robust downscaling models difficult.

The second barrier that has been mentioned by a number of climate modelers is the lack of capacity both in terms of human resources and computational capacity to expand the available databases. In particular, running dynamical downscaling models requires considerable computational capacity and there are currently few computers available on the continent which are powerful enough to run these models. Even when there is a super computer available, there are very few people that have the necessary capacity to develop and/or carry out downscaling activities. Apart from CSAG, there are a handful of other institutions (including ICPAC and ACMAD) that have some basic infrastructure and human resources in place but much more needs to be done to support these institutes in their evolution into fully-fledged climate modeling centers.

Despite these barriers and shortcomings, many climate scientists and donors feel that the state of climate science and modeling has reached a point where it is able to adequately support local decision making processes (Neil Leary, Bruce Hewitson, Mirjam Palm, Sean Doolan). The critical focus, however should be placed on the development of sector-specific methods and examples of how the climate data could be utilized to support robust adaptation responses. It follows that the objective of the modeling community is to focus on **expanding the modeling efforts within Africa while working closely and interactively with the users of model information in the interpretation and understanding of climate data.**

### 5.3 The use and application of climate change projection data in Africa

When it comes to the application and use of climate change projection data by researchers and practitioners in the agricultural sector in Africa a number of observations can be made.

Firstly, it should be noted that there is a growing awareness about the issue of climate change and many of the researchers as well as practitioners refer to the potential impacts of climate change on their sector. However, while awareness of and references to climate change are both increasing, much of these are based on media messages, or highly aggregated data from the IPCC (DDC) and GCM models. The link between climate change information and adaptation practitioners on the ground remains largely non-existent and many adaptation practitioners in the agricultural sector still rely on generalized assumptions about how the climate will change or derive very general information about climate change and its impacts from the IPCC reports. As previously noted, the applications of existing, improved resolution downscaled data to agricultural decision making is limited and, when used, **people tend to rely on only one model creating the risk of drawing unsubstantiated, or at best sub-optimal, inference.**

It also appears the case that the decision of what model or scenario to use is more than often based, not on that model's suitability to the research problem or adaptation challenge, but its ease of access and use, with the extreme, but still plausible adoption by simple word of mouth. Only rarely do researchers provide a science-based rationale for choosing one model over another.

It is also clear from a review that climate adaptation and agricultural development activity in Africa has been mobilized in response to foreign funding. In this sense the activity is "supply driven", and it is worth asking why there are so few programs conceived, planned and funded from within Africa. As Lorenz Peterson from GTZ emphasized, **there needs to be more focus on "demand driven" approaches that help to strengthen cooperation and understanding between donors and those impacted by climate change.**

It is probably not an understatement to say that, despite a growing recognition of the issues surrounding climate change among researchers and practitioners, there are very few examples where the climate change model data have actually been used to inform decision-



making. Even within the research community, the actual use and interpretation of these data is a recent advance (for example in some of the ACCCA projects).

The relatively few farmers who draw on the available climate projections is unsurprising. Most farmers base their decisions on short-term weather and seasonal climate variability, and stand to gain little from engaging with the complex world of climate projections and its difficult to apply messages. In the case of plant breeders, policy makers, government officials and donors, all of whom might be expected to adopt a longer-term focus, there is a greater need to engage with and apply the available climate projections.

Both researchers and practitioners interviewed attributed the failure to use model information to different dynamics:

- Lack of perceived relevance: Agricultural decision makers require information on a range of matters in order to manage their businesses and programs. Making the link between the type of data that are reported by climate change models (projections up to 2100) and the type of data that they perceive as being important to their activities (market demands, price, cost of inputs, labor availability, short-term weather) is not always possible, or in some instances is not considered a priority. Indeed, it posits a great challenge that is difficult to overcome.
- Gaining access to the right information remains a barrier: In spite of the fact that many climate change projections are freely available, farmers and agricultural decision makers do not know where to access this information and are not yet accustomed to searching for this information.
- Issues of spatial and temporal resolution: The perception that climate projections do not provide accurate information on the scale that land users and agricultural decision makers require, remains a critical problem. This is particularly true of issues related to temporal resolution. Because global and downscaled climate models tend to provide information for time periods more than ten years in to the future (typically from 2040s to 2100), farmers consider them inappropriate to their immediate decisions.
- Skepticism over reliability: For farmers and other agricultural decision makers, there are costs and risks involved when modifying their age-old activities and practices in order to adapt to what models indicate will happen. Some farmers and program operators noted that it makes more sense to react to observed (or historical) changes in weather than to alter their activities based on a predicted climate risk. It is further true that many decision makers are unable to contextualize the uncertainty that is inherent in climate projections and therefore stick to what they know. **The reality is, however, that most models concur on the direction of change in the near term. If used with the correct caution, these models can provide a sound, scientifically grounded basis for decision making.**

Difficulty in interpreting the detail of climate data: A large number of farmers and agricultural decision makers in Africa are aware of climate change and are painfully aware of how it might affect them. They are, however, unable to mobilize an adaptation response because they lack access to the appropriate tools and interpretation techniques necessary to evaluate these impacts. Whilst farmers might know that climate change is expected to make their country wetter on average, they may not be directly aware of the cascading effects of these patterns on their day to day activities. For example, they may not understand the interaction between precipitation and evapotranspiration that would dramatically alter soil moisture conditions, planting dates, etc. Nor would they understand the seasonal distribution of increased rainfall or how the frequency or intensity of rainfall events might alter.

- Specific user needs not addressed by the available climate data: Sean Doolan of DfID pointed out in his interview, that the majority of climate data available has been produced without due consideration of the specific (and admittedly diverse) needs of the people that might need to use them, and as such is packaged in a way that makes it difficult for practitioners to utilize. A farmer for example, may be less interested in mean annual temperature but would be very interested in knowing many years in a orchard life-time of say 25 years, they might expect to receive sub-optimal rainfall or extreme temperatures, and how this number can be expected to change. This might be impossible to infer from a reported temperature increase, especially where the relationship between extremes and averages is not established.
- Lack of translators: Climate change projections have been developed by climatologists yet there has not been sufficient growth in the people and institutions able to interpret and communicate this information effectively. These translation skills (of so-called boundary organizations) are necessary in order to engage a wide range of stakeholders with specific needs, as the limited number of climate scientists in Africa are unable to develop their science at the same time as meeting the growing need for data interpretation and communication.
- Climate data are accessed and understood but do not warrant an adaptation response: In a few instances farmers and agricultural program leaders have used the best available climate data in their assessment activities, their best decision was to continue with their existing practices – i.e. not to adapt, yet. DfID, for example, used PRECIS to screen the climate change impact on their portfolio of development projects in Africa (including non-agricultural projects), and convinced themselves whether correctly or not, that they did not need to take action now in order to safeguard the benefits of these projects under a changing climate.

The barriers and constraints to the appropriate use of climate change projection data are various but they all seem to point to a general lack of interaction and communication between data producers and data users about information needs and the possibilities and limitation of climate change projection data.

Whilst climate change modelers believe they are able to provide the type of data and information that can reliably inform local decision making and tend to attribute the limited use of climate change information to a general lack of capacity among researchers and practitioners to understand and apply the information, researchers and practitioners maintain that available climate change projection data remain difficult to access, and particularly difficult to apply with any measure of confidence to the types of decision that they need to take. This highlights again the need for translators.

Addressing this apparent disconnect between data producers and data users will be crucial for advancing the use of climate projection data in the agricultural sector in Africa.

An overarching challenge for African countries grappling with practical steps in climate change adaptation in agriculture, is to move beyond simply responding to UNFCCC and GEF reporting requirements, and to begin engaging in the dynamics of future climates and their implications. This will require the tailoring of climate information not only for awareness raising but for guiding context-specific responses.

## Chapter 6: Recommendations

Based on the analysis and assessment in the previous chapters, five broad recommendations are proposed that would improve the use and application of climate change projection data in the agricultural development sector in Africa.

### 6.1 Improving and expanding climate change projection data in Africa

In order to improve and expand the availability of climate change projection data in Africa a number of measures could be taken. Priority could be given to two types of measures.

Firstly, improved historical data is needed. Historical data are paramount to the examination and understanding of present climate variability and the implications of future scenarios. Reliable, quality controlled historical climate data is often not available. Data rescue activities that facilitate the digitization of archives currently on paper that are in many cases in the hands of a range of stakeholders including meteorological stations and farmers would improve this. It was noted by various interviewees that there are many so-called “volunteer stations”, i.e. people or projects keeping records of weather data on a voluntary basis. In Kenya, for instance, it is estimated that there are around 600 manned and operated volunteer stations as opposed to only 25 “official” meteorological stations. Often these data consist of long time series dating back as much as 40-50 years. Data rescue efforts to convert these to workable/digital formats could be a very valuable contribution to overcoming the current data constraints across Africa, improving the quality of climate modeling and downscaling efforts. GCOS is involved in a pilot project starting in 2008 that addresses some of these data rescue issues in Africa.

Secondly, more capacity building efforts are needed to train climate scientists in Africa in the development and application of downscaling techniques as well as in the use of multi-model approaches. The START African Climate Change Fellowship Program aims to address this gap, though more resources are needed to support graduate students and provide subsequent employment opportunities for them at the post-doctoral level in order to encourage their continued involvement and contribution to the development and application of climate data. Simultaneously, efforts should galvanize the establishment of regional climate science centers in Africa that have the necessary computational and institutional capacities to support climate modeling and downscaling activities.

### 6.2 Bringing data producers and data users together

More opportunities that join agricultural decision makers and climate scientists, and provide an environment in which the skills necessary for closer collaboration between these two groups could be created. These interactions should aim to:

- Improve data users' understanding of the possibilities and limitations of climate change projection data and, as such build their capacity in interpreting and applying the data in a correct and appropriate way.

- Improve data producers' understanding about the information needs of different user groups and, as such, enable them to tailor and package their data in ways that are more useful for agricultural decision makers.
- Support translators who understand the challenges on both sides and can act as information conduits. The challenge with this task is that it requires skills that many of the people currently engaged in climate change adaptation simply have not developed. Specifically it requires the ability to translate science concepts into those that users understand and can use, without distorting the concepts. It also requires in-depth understanding of users' needs and the potential opportunities for using climate change projection data. The NCAP project in Mali is beginning to address some of these concerns, but more efforts are needed.

### **6.3 Improving capacity to interpret and apply climate data**

The ability to draw correct inference from climate data from different sources, and to apply these data in decision making could be standardized in the format of a training module. The module could be made available to government officials, agricultural decision makers and farmers as a means of strengthening their capacity to draw appropriately on available data. The training module could also, of course, raise awareness of the available data as it evolves. Standard modules could be developed that would need country specific input to make them relevant to local stakeholders.

### **6.4 Move from awareness raising to “proof of concept”**

With the climate change debate gradually moving from a focus on awareness raising about the problem to the development of actual adaptation responses, there is a need for developing so-called “proofs of concept” – examples of agricultural decision makers that have successfully drawn on climate change projection data to make decisions that have improved agricultural productivity or human well-being. “Proofs of concept” could also provide an opportunity to quantify and assess the potential value and benefits of using climate change projection data as opposed to not using climate change projection data at all. However, the long term nature of climate change will make “proof of concept” examples hard to evaluate.

### **6.5 Platforms as the backbone for collaborative action and information sharing**

The Oxford English Dictionary defines platform as “*an opportunity for the expression or exchange of views*”. Climate change adaptation platforms could be seen as spaces for collaborative action and information sharing. These platforms could be developed in a number of ways and fulfill an equally large number of functions:

- Platforms could provide a space where scientists, researchers, decision makers and practitioners could share their knowledge and experience on climate change adaptation and engage in a process of mutual learning.

- Platforms could function as repositories for local climate and weather information in order to improve accessibility.
- Platforms could store information about tools and methodologies for assessing the impacts of climate change and contribute to the development of appropriate adaptation strategies.
- Platforms could be supported by material from workshops, fellowships, mailing lists or e-conferences and collaborative outputs (including academic papers, policy briefs and information sheets) where agricultural development practitioners engage with climate scientists and/or climate information and document the process and their learning.

By design a platform focused on climate change adaptation would have to be multi-disciplinary, including agricultural technicians, climate science experts, local communities/civil society and donors, with obvious links to policy makers. One example is that of the weAdapt platform, which unites modelers, practitioners, donors and others via a suite of new and innovative tools and methods, datasets, experiences and guidance that are a resource for strengthening the capacity of those tasked with undertaking adaptation.

One of the entry points to the platform is an interactive wiki space such as ([www.weAdapt.org](http://www.weAdapt.org)), which provides a structure and forum for reading about, discussing and contributing to current thinking and experience on climate adaptation. It also includes stories about living with climate variability and change from stakeholders in Africa, challenges in developing NAPAs and suggestions on the use of climate information. It is label-free and institutions are encouraged to contribute by adding to existing pages or developing new pages and components. Recent experiences at the Conference of Parties in Bali (2007) catalyzed partnerships that are certain to provide new and innovative avenues for collaboration and sharing of climate data, experience, and expertise.

Another key element of the weADAPT platform is the Climate Change Explorer (CCE) tool, with routines that permit access to, and exploration of attributes of the past and projected future climate. Indeed, the CCE tool development process itself is a testament to the potential synergies to be gained from encouraging and supporting the interaction between providers and users of information.

## **6.6 Focused donor funding**

Many donor agencies are currently undergoing a similar process of gap analysis and exploration of opportunities for coordination in order to direct future funding strategies. Since most of these processes are still ongoing it is difficult at this moment to draw final conclusions. Nevertheless some issues seem to be emerging.

In the past three years, donor agencies have shown an increasing interest in the issue of climate change adaptation. In order to avoid the vagaries of supply driven interventions that bear little reference to local needs and priorities, it is essential that the volume of

funding that is being released focus on the needs that seem to be emerging from within Africa.

In order to do this it is important to **support processes not projects**. Although projects can facilitate the development of technical capacity to interpret and use climate information, experience has shown that building capacity for the appropriate use of climate information is a tedious and resource intensive process that takes time. Therefore it is important that existing networks are strengthened and funding goes beyond project specific skills creation to develop institutional capacity and stability, which requires a lot of inputs from different stakeholders.

Presently some donors are supporting independent adaptation projects that first assess impacts and vulnerability to climate change and then develop relevant adaptation strategies, whilst others are focusing on development projects at the inception phase and integrating climate throughout the project cycle. Both approaches have their merits yet the aims of the approach should be clearly stated.

Even though there is an institutional deficit in Africa, there are local and international institutions starting to explore the field. **Building on these existing institutions and networks has many advantages** as opposed to creating new ones. In general, existing institutions can benefit from a long-standing presence in the region and they have typically built up credibility and trust among stakeholders. Often they are already grounded in the local reality with an understanding of the local needs and some knowledge about how to deal with institutional constraints that characterize a certain country. Certainly this is the case for Michigan State University's work in East Africa which has been able to build on long-standing affiliations through the Climate-Land Interaction Program (CLIP) and has undertaken some ambitious modeling of the relationships between local agricultural practices and climate. Some people have argued that supporting such institutions that have emerged from local needs is more likely to continue and be sustainable although the moral hazards of international support for local institutions should be fully acknowledged in these processes.

Finally, there is an increasing number of private sector donors such as the Bill and Melinda Gates Foundation, The Google Foundation and the Rockefeller Foundation, and a burgeoning group of consultants and NGOs targeting research and implementation opportunities. To ensure an effective response and avoid overlap, discussions will need to take place between the existing donors and these new players in order to identify roles and responsibilities.

## **6.7 Placing climate change within the broader African development context**

This study has provided an overview of the type of institutions and activities dealing with climate science, agricultural development and adaptation in Africa. It has highlighted the challenges associated with producing, disseminating, interpreting and using climate data. In addressing these challenges it is important to recognize the context in which climate change should be addressed in Africa – as urgent yet one of many other development challenges

that Africa is dealing with. However, a common sentiment as reiterated by UN Secretary-General Ban Ki-moon' address to the tenth African Union Summit in Addis Ababa, Ethiopia (AU Summit, 2008), is that "our best efforts in peace, development and human rights will be undermined if we do not effectively address the threats posed by climate change."



## Bibliography

- Adejuwon JO (2005) "Food crop production in Nigeria. I: Present effects of climate variability" *Climate Research* 30 53-60
- Adejuwon JO (2006) "Food crop production in Nigeria. II: Potential effects of climate change" *Climate Research* Vol 32 229-245
- African Union Summit. 2008. Ban Ki-Moon. Secretary-General's address to the Summit of the African Union. Addis Ababa, Ethiopia, 31 January 2008.  
<http://www.un.org/apps/sg/sgstats.asp?nid=2978>
- Agoumi, A., (2003) Vulnerability of North African countries to climatic changes: Adaptation and implementation strategies for climatic change. In *Developing Perspectives on Climate Change: Issues and Analysis from Developing Countries and Countries with Economies in Transition*. IISD/Climate Change Knowledge Network, 14 pp. [http://www.cckn.net//pdf/north\\_africa.pdf](http://www.cckn.net//pdf/north_africa.pdf)
- Archer, E.R.M., Oetllé, N.M., Louw, R, Tadross, M.A. (In Press). 'Farming on the Edge' in arid western South Africa: adapting to climate change in marginal environments. *Geography*. June 2008.
- Boko, M., I. Niang, A. Nyong, C. Vogel, A. Githeko, M. Medany, B. Osman-Elasha, R. Tabo and P. Yanda. (2007) *Africa in Climate Change 2007: Impacts, Adaptation and Vulnerability*. Contribution of Working Group II to the Fourth Assessment Report of the Intergovernmental Panel on Climate Change, M.L. Parry, O.F. Canziani, J.P. Palutikof, P.J. van der Linden and C.E. Hanson, Eds., Cambridge University Press, Cambridge UK, 433-467.
- Christensen, J., Hewitson, B.C., Busuioc A., Chen, A., Gao., X., Jones, R., Kwon, W.-T., Laprise, R., Magana, V., Mearns, L. Menenedez, C., Raisaenen, J., Rinke, A., Kolli, R. K. and Sarr, A. (2007). *Regional Climate Projections*, in IPCC Fourth Assessment Report "Climate Change 2007: The Scientific Basis", Cambridge University Press.
- Easterling, III, W. E., P. R. Crosson, N. J. Rosenberg, M. S. Mckenney, L. A. Katz and K. M. (1993) "Agricultural impacts of and responses to climate change in the Missouri-Iowa-Nebraska-Kansas (MINK) region" *Climate Change* 24: 23-62.
- Eid, H. M., El-Marsafawy, S. M. and Ouda, S. A. 2006: *Assessing the impacts of climate change on agriculture in Egypt: A ricardian approach*. Centre for Environmental Economics and Policy in Africa (CEEPA) Discussion Paper No. 16, Special Series on Climate Change and Agriculture in Africa, University of Pretoria, Pretoria, 1-33.
- FAO. Food and Agricultural Organisation of the United Nations. (2003). *Responding to Agricultural and Food Insecurity Challenges Mobilising Africa to Implement Nepad Programmes*. Conference of ministers of agriculture of the African Union, Maputo, Mozambique. 1-2 July, 2003.

- FAO Interdepartmental Working Group on Climate Change. 2007. *Climate Change and Food Security: A Framework for Action*. Rome.
- Gregory, P.J., Ingram, J.S.I. and Brklacich, M. (2005). Climate change and food security. *Philosophical Transactions of the Royal Society B*. Vol. 36: 2139-2148.
- Hellmuth, M.E., Moorhead, A., Thomson, M.C. and Williams, J. (eds) 2007. *Climate risk management in Africa: Learning from practice*. International Research Institute for Climate and Society (IRI), Columbia University, New York, USA.
- Houghton JT, Ding Y, Griggs DJ, Noguer M van der, Linden PJ, Xiaosu D (2001) *Climate Change 2001: The Scientific Basis, Contribution of Working Group I to the Third Assessment Report*, Cambridge University Press
- Hulme, M; T.M.L. Wigley; E.M. Barrow; S.C.B. Raper; A. Cantella; S. Smith; and A. C. Chipanshi (2000) Using a climate scenario generator for vulnerability and adaptation assessments: MAGICC and SCENGEN Version 2.4, Workbook Climate Research Unit, East Anglia University, Norwich.
- Insitful, J.D. (2006) *Regionalisation Techniques and Regional Climate modeling*. CGE hands on training workshop on V&A. Asuncion, Paraguay. 14-18 August.
- IPCC (2007) Summary for Policymakers. In: *Climate Change 2007: Impacts, Adaptation and Vulnerability. Contribution of Working Group II to the Fourth Assessment Report of the Intergovernmental Panel on Climate Change*, M.L. Parry, O.F. Canziani, J.P. Palutikof, P.J. van der Linden and C.E. Hanson, Eds., Cambridge University Press, Cambridge, UK, 7-22.
- Jodha, N. S. (1989) "Potential strategies for adapting to greenhouse warming: Perspectives from the developing world". In: N. J. Rosenberg et al. (ed.). *Greenhouse Warming: Abatement and Adaptation, Resources for the Future*. Washington, DC, 147-158
- Jones, R. and Wilson, S. (2002) PRECIS: Providing Regional Climates for Impact Studies. A presentation to the Tyndall Centre AIACC training workshop. 23 April 2002.
- Lasco RD, Cruz RVO, Pulhin JM, Pulhin FB (2008) "Spillovers and trade-offs in adaptation watershed of the Phillipines" in Leary N, Adejuwon J, Barros V, Burton I and Kulkarni I (eds) *Climate Change and Adaptation*, Earthscan Publications, London. 247-263
- Leary, Neil (2008) "A stitch in time: General lessons from specific cases" in Leary N, Adejuwon J, Barros V, Burton I and Kulkarni I (eds) *Climate Change and Adaptation*, Earthscan Publications, London. 1-28
- Mendelsohn, R., A. Dinar and A. Dalfelt (2000) *Climate change impacts on African agriculture. Preliminary analysis prepared for the World Bank*, Washington, District of Columbia, 25 pp
- Molua, E. (2002). Climate variability, vulnerability and effectiveness of farm-level adaptation options: the challenges and implications for food security in Southwestern Cameroon. *Environment and Development Economics*, 7, 529-545.

- Nyong, T. (2005). Report on Africa-wide consultation on DFID/IDRC proposed collaborative research and capacity development program on climate adaptation research. Report for DFID/IDRC.
- Patt, A. G., Ogallo, L. and Hellmuth, M. (2007) Learning from ten years of Climate Outlook Forums in Africa. *Science* 318, 49-50.
- Pelling M, Maskrev A, Ruiz P, and Hall L (2004) Reducing Disaster risk: A challenge for development; United Nations Development Bank, Bureau for Crisis Prevention and Recovery, New York
- Reason, C.J.C., S. Hachigonta and R.F. Phaladi, 2005: Interannual variability in rainy season characteristics over the Limpopo region of southern Africa. *International Journal of Climatology*, 25, 1835-1853.
- Reid, P. and Vogel, C. (2006) Living and responding to multiple stressors in South Africa—Glimpses from KwaZulu-Natal. *Global Environmental Change* 16 (2), 195-206.
- Rosenberg, N. J. (1992) “Adaptation of agriculture to climate change”. *Climatic Change*, 21:385-405.
- Salinger, J; Sivakumar, M V.K. and Motha, R. P. (Eds.) (2005) *Increasing Climate Variability and Change: Reducing the Vulnerability of Agriculture and Forestry*. Reprinted from *Climatic Change*, Vol. 70, Nos. 1-2, 2005, VI, 362 p., Hardcover.
- Stainforth, D.A; Downing, T.E.; Washington, R; Lopez, A and New, M (2007) Issues in the Interpretation of Climate Model Ensembles to Inform Decisions. *Philosophical Transactions of the Royal Society*, 365, pp. 2163-2177.
- Stige, L.C., J. Stave, K.S. Chan, L. Ciannelli, N. Pretorelli, M. Glantz, H.R. Herren and N.C. Stenseth (2006) The effect of climate variation on agro-pastoral production in Africa. *P. Natl. Acad. Sci. USA*, 103, 3049-3053.
- Tadross, M. (2006) Climate change scenarios for the Olifants catchment area. In "South Africa Pilot Study Report: Climate Change and Water Resource Planning in Polokwane" prepared for the U.S. Agency for International Development by Stratus Consulting Inc. PO Box 4059 Boulder, CO. pp 139.
- Tadross, M.A., Jack C., and Hewitson B.C. (2005) On RCM-based projections of change in southern African summer climate. *Geophysical Research Letters*, 32(23), L23713, doi 10.1029/2005GL024460.
- Taylor MA, Chen A, Rawlins S, Heslop-Thomas C, Amarakoon D, Bailey W, Chadee Huntley S, Rhoden C, Stennett R (2008) “Adapting to Dengue Fever in the Caribbean” in Leary N, Adejuwon J, Barros V, Burton I and Kulkarni I (eds) *Climate Change and Adaptation*, Earthscan Publications, London. 1-28
- Thornton PK, Jones PG, Owiyo T, Kruska RL, Herrero M, Kristjanson P, Notenbaert A, Bekele N and Omolo A, with contributions from Orindi V, Otiende B, Ochieng A, Bhadwal S, Anantram K, Nair S, Kumar V and Kulkar U (2006). Mapping climate vulnerability and poverty in Africa. Report to the Department for International Development, ILRI, Nairobi, Kenya. Pp 171.

- Tubiello FN, Rosenzweig C, Goldberg RA, Jagtap S, Jones JW (2002) “Effects of climate change on US crop production: simulation results using two GCM scenarios. Part I: Wheat, potato, maize, and citrus” *Climate Research* 20: 259 – 270.
- United Nations Development Programme (UNDP) (2007) *Adaptation Learning Mechanism: learning through sharing experience*. [www.adaptationlearning.net](http://www.adaptationlearning.net)
- Wilby, R. (2007) *Decadal Climate Forecasting Techniques for adaptation and development planning*. Report for DfID.
- Wilby, R., Dawson, C.W. and Barrow, E.M. (2002) SDSM — a decision support tool for the assessment of regional climate change impacts. *Environmental Modelling & Software*. 17. 147–159.
- Wigley, T. M. L. (2004). MAGICC/SCENGEN. Boulder, Colorado National Center for Atmospheric Research. <http://www.cgd.ucar.edu/cas/wigley/magicc/>
- Working Group on Climate Change and Development (2006). *Africa – Up in smoke 2*. New Economics Foundation, London, pp20.
- Zeray, L., Roehrig, J. and Chekol, D.A.. Tropentag, October 11-13, (2006) Bonn. “Prosperity and Poverty in a Globalised World - Challenges for Agricultural Research” *Climate Change Impact on Lake Ziway Watershed’s Water Availability, Ethiopia*
- Ziervogel, G., Bharwani, S. and Downing, T.E. (2006) Adapting to climate variability: pumpkins, people and policy. *Natural Resource Forum*. 30 (4). 294–305.
- Ziervogel, G. and Taylor, A. (2008). Feeling Stressed: Integrating Climate Adaptation with Other Priorities in South Africa. *Environment*. 50, 2. 32-41.

## Appendix A: Stakeholders interviewed

Institution	Name of person interviewed	Country
ACCCA project	Mathieu Badolo	Burkina Faso
Jomo Kenyatta University (ACCCA project)	John Gathenya	Kenya
Red Cross (ACCCA project)	Ethel Kamaila	Malawi
ACMAD	Mohamed Kadi	Niger
AERC	Olu Ajakaiye	Nigerian based in Kenya
AGRA	Joe de Vries	Nairobi
AGRHYMET	Hubert N'Djafa Ouaga	Niger
ALMP	James Oduor	Kenya
CCAA	Anthony Nyong	Kenya
Centre for Arid Zones Studies	Prof Adeniji	Nigeria
CGIAR	Ann-Marie Izac	Rome
CSAG (University of Cape Town)	Bruce Hewitson and Mark Tadross	South Africa
CSAG (University of Cape Town) and Iowa State	Babatunde Abiodun	Nigerian in South Africa
DFID	Lennard Tedd and Sean Doolan	UK
DGIS	Christine Pirenne	Netherlands
FEWSNET	Yahaye Tahirou	Nigeria
GCOS	William Westermeyer	Switzerland
GTZ	Lorenz Peterson	Germany
IAR&T	A.G. Oluwatosin	Nigeria
ICPAC	Chris Oludhe and Bwango Apuuli	Kenya
ICRAF	Louis Verchot	Kenya
ICRISAT	Peter Cooper	Kenya
IIASA	Anthony Patt	Austria
IIED	Simon Anderson	UK
IITA	Kai Sonder	Nigeria
Lake Chad research institute	Bukar Bababe and S. Aji	Nigeria
LEAD Network	Kenneth Gondwe	Malawi
Ministry of Environment and Sanitation, Mali. ACCCA-NCAP project	Boubacar Sidiki Dembele	Mali
Buea University, Economics Dept (ACCCA project)	Molua, E	Cameroon
MSU (International)	Jennifer Olsen	Lives in Michigan, works in

Livestock Research Institute)		Kenya
Nigeria MOE (Special climate change unit)	S Adejuwon	Nigeria
Rockefeller Foundation	Peter Matlon (African Regional Program)	Nairobi (left in 2007)
SDSM	Rob Wilby	UK
SIDA	Mirjam Palm (Climate Advisor)	Sweden
SSN Africa	Adele Arendse	South Africa
START International	Neil Leary	USA
SEI (Oxford)	Tom Downing	UK
Tyndall Centre	Andrew Watkinson	UK
University of Pretoria / Jabenzi	James Blignaut	South Africa
USAID	John Furlow	USA
Walker Institute for Climate Systems research	Maria Noguer	United Kingdom
World Vision	Joe Muwonge	Kenya
Zambia Meteorological Services	Oversease Mwangase	Zambia