



Leica CM1850

Cryostat

Instruction Manual

Leica CM1850 V2.2 English – 12/2003

Always keep this manual near the instrument!

Read carefully prior to operating the instrument!

Leica

MICROSYSTEMS

The information, numerical data, notes and value judgments contained in this manual represent the current state of scientific knowledge and state-of-the-art technology as we understand it following thorough investigation in this field. We are under no obligation to update the present manual periodically and on an ongoing basis according to the latest technical developments, nor to provide our customers with additional copies, updates etc. of this manual.

For erroneous statements, drawings, technical illustrations etc. contained in this manual we exclude liability as far as permissible according to the national legal system applicable in each individual case. In particular, no liability whatsoever is accepted for any financial loss or consequential damage caused by or related to compliance with statements or other information in this manual.

Statements, drawings, illustrations and other information as regards contents or technical details of the present manual are not to be considered as warranted characteristics of our products.

These are determined only by the contract provisions agreed between ourselves and our customers. Leica reserves the right to change technical specifications as well as manufacturing processes without prior notice. Only in this way is it possible to continuously improve the technology and manufacturing techniques used in our products.

This document is protected under copyright laws. Any copyrights of this document are retained by Leica Microsystems Nussloch GmbH.

Any reproduction of text and illustrations (or of any parts thereof) by means of print, photocopy, microfiche, web cam or other methods – including any electronic systems and media – requires express prior permission in writing by Leica Microsystems Nussloch GmbH.

For the instrument serial number and year of manufacture, please refer to the name plate at the back of the instrument.

© Leica Microsystems Nussloch GmbH



MICROSYSTEMS

Leica Microsystems Nussloch GmbH
Heidelberger Str. 17 - 19
D-69226 Nussloch
Germany

Phone: +49 (62 24) 143-0
Fax: +49 (62 24) 143-200
eMail: histo_info@leica-microsystems.com
Internet: <http://www.histo-solutions.com>

Table of contents

1.	Important Information	6
1.1	Symbols used in this manual and their meaning	6
1.2	Qualification of personnel	6
1.3	Designated use	6
1.4	Instrument type:	6
2.	Safety	7
2.1	Safety features	7
2.1.1	Locking the handwheel	7
2.1.2	Knife guard	8
2.2	General information on instrument design and safe handling	8
2.3	Operating conditions	9
2.5	Cleaning and disinfection	10
2.6	Removal of the microtome	10
2.7	Maintenance	11
3.	Technical data	12
4.	Unpacking and installation	14
4.1	Site requirements	14
4.2	Transport to the desired location	14
4.3	Standard delivery	15
4.4	Handwheel assembly	16
5.	Setup	17
5.1	Connection to mains power	17
5.2	Prior to operation	17
5.3	Leica CM1850 - Overview	18
5.4	Mains switch and automatic mains fuse	20
5.5	Turning the instrument on	20
6.	Control panel operation	21
6.1	Control panel 1	21
6.2	Programming the desired values	21
6.2.1	Setting the time	21
6.2.2	Setting the automatic defrost time (cryochamber)	22
6.2.3	Selecting the cryochamber temperature	22
6.2.4	Activation of the Peltier element (option)	23
6.2.5	Manual defrosting of the quick freeze shelf	23
6.2.6	Manual defrosting of the cryochamber	24
6.3	Display lock	24
6.4	Control panel 2 - Electric coarse feed	25

7.	Daily use of the instrument	26
7.1	Specimen freezing	26
7.1.1	Quick freeze shelf	26
7.1.2	Stationary heat extractor (accessory)*	26
7.2	Specimen discs	27
7.2.1	Inserting the specimen discs in the specimen head	27
7.2.2	Specimen orientation	27
7.3	Sectioning	28
7.3.1	Trimming the specimen	28
7.3.2	Section thickness setting	28
7.4	Temperature selection chart (in minus °C)	29
7.5	Defrosting	30
7.5.1	Automatic defrosting of the cryochamber	30
7.5.2	Manual defrosting of the cryochamber	30
7.5.3	Manual defrosting of the quick freeze shelf	31
7.6	Terminating work	31
7.6.1	Terminating daily work	31
7.6.2	Shutdown for a longer period	32
8.	Troubleshooting	33
8.1	Error messages in the display	33
8.2	Temperature control button	33
8.3	Possible causes and remedies	34
9.	Cleaning, disinfection, maintenance	39
9.1	Cleaning	39
9.2	Spray disinfection with Leica Cryofect	40
9.3	Maintenance	41
9.3.1	General maintenance	41
9.3.2	Removal of the microtome	42
9.3.3	Removal of the microtome cover	44
9.3.4	Reinstallation of the microtome	44
9.3.5	Replacement of the fuses	46
9.3.6	Replacement of the lamp	46
10.	Ordering information, optional accessories	48
10.1	Ordering information	48
10.2	Optional accessories	49
10.2.1	Mobile heat extractor	49
10.2.2	Thermal block	49
11.	Warranty and service	50

1.1 Symbols used in this manual and their meaning



Warnings
appear in a grey box and are marked by a warning triangle .



Notes
i.e. important user information appears in a grey box and is marked by an information  symbol.

(5)
(Fig.5) Figures in brackets refer to item numbers in drawings or to the drawings themselves.

1.2 Qualification of personnel

The Leica CM1850 may only be operated by trained laboratory personnel.

All laboratory personnel designated to operate the instrument must carefully read the present instruction manual prior to starting work with the instrument.

1.3 Designated use

The Leica CM1850 is a powerful cryostat for routine as well as research applications in biology, medicine and industry.

The instrument has been designed for rapid freezing and sectioning of tissue samples.

The instrument has not been designed for unattended storage of tissue material.

The instrument may only be operated within the scope of its designated use as described above and as per the instructions given in this manual.

Any other use of the instrument is considered improper.

1.4 Instrument type:

All information given in this instruction manual applies only to the instrument type indicated on the title page.

A name plate, indicating the instrument serial number, is attached to the back of the instrument.



Fig. 1

This instruction manual includes important instructions and information related to the operating safety and maintenance of the instrument.

The instruction manual is an important part of the product. It must be read carefully before using the instrument for the first time and must always be kept with the instrument.

If additional requirements, which exceed the scope of this manual, are imposed by regulations and/or laws on accident prevention and environmental protection in the country of operation, appropriate instructions for compliance with such requirements must be added to this manual.

Read this instruction manual carefully before attempting to use or operate the instrument.

2.1 Safety features

The instrument and its accessory equipment incorporate the following safety features: safety handwheel and knife guards on the knife holders.

The consistent use of these safety features and strict observation of the warnings and cautions in this manual, will safeguard the operator from accidents and/or personal injury to a great extent.

2.1.1 Locking the handwheel

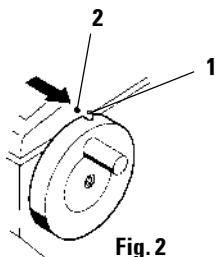

Prior to manipulating the knife and specimen, or changing the specimen or knife, and during breaks, always lock the handwheel!

For locking the handwheel rotate the handle until it is in the upper position. Push the locking pin (1) into the recess at the handwheel. The locking position is marked by a black dot (2). If necessary, move the handwheel slightly forth and back until the locking mechanism engages.

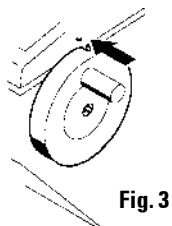

To unlock, push the locking pin (1) to the left from the recess at the handwheel.

2. Safety

2.1.2 Knife guard



For every manipulation in the cryochamber, or upon changing a specimen when the knife or disposable blade is clamped, or during breaks, cover the cutting edge with the knife guard.

The knife holders CN and CS are equipped with knife guards; on the knife holder CE the glass plate of the anti-roll guide constitutes the knife guard (please refer to the separate instruction manual for your knife holder). Prior to manipulating the knife and specimen, or changing the specimen or knife, and during breaks, always lock the handwheel!

2.2 General information on instrument design and safe handling

This instrument has been built and tested in accordance with the following safety regulations on electrical measuring, control, regulating and laboratory devices:

- DIN EN 292,
 - DIN EN 61010-1,
 - EN 50082-1,
 - EN 55011,
 - IEC 1000-4
- as well as according to the international quality standard,
- DIN ISO 9001.

In order to maintain this condition and to ensure safe operation, the operator must observe the instructions and warnings contained in this instruction manual.

2.3 Operating conditions

Transport and installation

- After transporting do not turn the instrument on for a minimum of 4 hours!
- Do not operate in rooms with explosion hazard!
- To ensure an adequate cooling capacity, the instrument must be set up with at least 10 cm distance from walls and furniture!

Connection to mains

- Before connecting to the mains power, please check if the local voltage complies with the power rating specified on the name plate of the instrument!
- During the compressor start-up the nominal voltage must not drop below the values specified in the 'Technical data'!
The compressor requires a start-up current between 45 and 50 A. Therefore, the electric circuit at the place of installation must be inspected by an electrical engineer to ensure that it meets the requirements for a smooth operation of the instrument.
A constant adequate power supply to the instrument must be ensured at all times.
Failure to comply with the above will cause severe damage to the instrument.
- After transporting, wait at least 4 hours before turning the instrument on.
This waiting period is necessary to allow the compressor oil, which may have been displaced during transport, to return to its original position.
Failure to comply with this can cause severe damage to the instrument.

Defrosting

- The quick freeze shelf may become hot during defrosting!
Therefore, do not touch it!

2.4 Operating the instrument

- Take care when handling microtome knives and disposable blades. The cutting edge is extremely sharp and can cause severe injury!

2. Safety

- Never leave knives and knife holders with a knife/blade mounted lying around!
- Do not place a knife on a table with the cutting edge facing upward!
- Never try to catch a falling knife!
- Always clamp the specimen before the knife!
- Prior to manipulating the knife and specimen, or changing the specimen or knife, and during breaks, always lock the handwheel and cover the cutting edge with the knife guard!
- Avoid contact with cold parts of the instrument as this can cause frostbite!
- To make sure that the condensation water stemming from the defrost cycles drains into the waste container and to avoid the risk of possible contaminations, ensure that the tap of the waste container (2, Fig. 31.1) is open when operating the instrument. Only shut the tap when draining the waste container!

2.5 Cleaning and disinfection

- It is not necessary to remove the microtome for routinely disinfecting the cryochamber.
The instrument is appropriate for spray disinfection with Leica Cryofect!
- Do not use organic solvents or any other aggressive substances for cleaning and disinfection!
Only use the cleaning agents and disinfectants specified in this instruction manual such as Leica Cryofect (alcohol or common disinfectants based on alcohol)!

2.6 Removal of the microtome

- Prior to removing the microtome, turn the instrument off with the mains switch and pull the mains plug.
- Prior to removing the microtome, bring the specimen head to the lower position with the handwheel.
Otherwise the specimen head would rapidly fall down and might injure the operator's hands, when taking out the microtome.
- Wear appropriate protective gloves to take the cold microtome out of the cryochamber.

Extended skin contact with cold parts of the instrument may cause frost bite!

- The microtome must be entirely dry before reinstallation. Humidity inside will condense and freeze in the cold cryostat and thus cause malfunctions or damage.
- Do not use external heaters for drying the cryochamber. This can cause damage to the cooling system!
- All components removed from the cryostat must be carefully dried before they are replaced in the cryochamber

.2.7 Maintenance

Replacement of the fuses

- Turn the instrument off with the automatic mains fuse and pull the mains plug, before replacing the fuses.
- Only use fuses of the same specification! For the required values, please refer to Chapter 3 'Technical data'.

The use of fuses other than specified by the manufacturer may cause severe damage to the instrument!

Replacement of the lamp

- Turn the instrument off with the automatic mains fuse and pull the mains plug, before replacing the lamp.
- If the lamp is broken, it must be replaced by the technical service, as the replacement involves a high risk of injury.

3. Technical data



Operating temperature range (ambient temperature): 18 °C to 40 °C.
All specifications related to temperature are valid only up to an ambient temperature of 22 °C and an air humidity lower than 60%!

Type	CM 1850	CM 1850	CM 1850-08	CM 1850-01
Mark of conformity	CUL	-	-	VDE
Nominal voltage (±10%)	120 V AC	220 V AC	230 V AC	240 V AC
Nominal frequency	60 Hz	60 Hz	50 Hz	50 Hz
Power draw	1600 VA	1600 VA	1600 VA	1600 VA
Max. start-up current for 5 sec	45A eff.	45A eff.	45A eff.	45A eff.
Protective class	I	I	I	I
Automatic mains fuse	T12A T1	T12A T1	T10A T1	T10A T1
Pollution degree	2	2	2	2
Overvoltage installation category	II	II	II	II
Heat emission (max.)	1600 J/s	1600 J/s	1600 J/s	1600 J/s

Refrigeration system	50 Hz	60 Hz
Cryochamber		
Temperature setting range	0°C to -35°C (+ 2 K / - 0 K)	0°C to -35°C (+ 2 K / - 0 K)
Defrosting	automatic hot gas defrosting, temperature controlled 1 automatic defrost cycle/24 hours, temperature controlled manual defrost cycle	automatic hot gas defrosting, temperature controlled 1 automatic defrost cycle/24 hours, temperature controlled manual defrost cycle
Refrigeration capacity	690 W	690 W
Safety factor	3	3
Refrigerant	300 g ±5g refrigerant R 404A *	300 g ±5g refrigerant R 404A *
Compressor oil	0.6 l EMKARATE RL-22S, ICI *	0.6 l EMKARATE RL-22S, ICI *
Quick freeze shelf		
Max. temperature	-40°C (+ 0 K / - 2 K)	- 40°C (+ 0 K / - 2 K)
Number of quick freeze stations	10	10
Defrosting	manual hot gas defrosting time controlled	manual hot gas defrosting time controlled
Peltier element (option)		
Max. temperature	-60°C (+5 K)	-60°C (+5 K)
Number of freezing stations	2	2*
Defrosting	together with quick freeze shelf	together with quick freeze shelf



*** Refrigerant and compressor oil must only be replaced by qualified, authorized service personnel!**

Microtome

Rotary microtome	
Section thickness setting	1 - 60 µm
Specimen feed	25 mm
Vertical stroke	59 mm
Maximum specimen size	55 x 55 mm
Specimen orientation	8° (x-, y-, z-Achse)
Electric coarse feed	
slow	0.2 mm/s
rapid	0.7 mm/s

Fluorescent lamp

50 Hz version:	Osram Dulux S 11 W/21
	Color: LUMILUX light white
60 Hz version:	Osram Dulux S 13 W/21
	Color: LUMILUX light white

① according to IEC-1010, UL 3101

② according to CECOMAF

Liquid temperature 45 °C

Evaporation temperature -25 °C

Cryocabinet

Dimensions	
Width (w/o handwheel)	600 mm
Width (with handwheel)	730 mm
Depth	730 mm
Height	1140 mm



Please refer to section 5.2 'Site requirements'!

Weight (incl. microtome,
without specimen cooling) approx. 135 kg

All CM 1850 types require the following fuses:

F1:	T0,25 A	Fa. Schurter, Typ FST; 6,3x32 mm	or	T0,25 A	Fa. Littlefuse, Typ 313; 6,3x32 mm
F2:	T0,6 A	Fa. Schurter, Typ FST; 6,3x32 mm	or	T0,6 A	Fa. Littlefuse, Typ 313; 6,3x32 mm
F3:	T1,6 A	Fa. Schurter, Typ FST; 6,3x32 mm	or	T1,6 A	Fa. Littlefuse, Typ 313; 6,3x32 mm
F4:	T6,25 A	Fa. Schurter, Typ FST; 6,3x32 mm	or	T6,25 A	Fa. Littlefuse, Typ 313; 6,3x32 mm
F5:	T4 A	Fa. Schurter, Typ FST; 6,3x32 mm	or	T4	Fa. Littlefuse, Typ 313; 6,3x32 mm

4. Unpacking and installation

4.1 Site requirements



Do not operate in rooms with explosion hazard! To ensure an adequate cooling capacity, the instrument must be set up with at least 10 cm distance from walls and furniture.

- The place of installation must meet the following requirements:
 - no direct sunlight,
 - mains power socket at a distance no greater than approximately 1.5 m,
 - no drafts (air condition outlets, etc.) directly over the instrument,
 - even floor,
 - mainly vibration-free floor,
 - obstruction-free access to the handwheel,
 - room temperature max. 35 °C,
 - Air humidity must not exceed 60 % High room temperatures and excessive air humidity affect the cooling capacity of the cryostat.



High room temperatures and excessive air humidity affect the cooling capacity of the cryostat.

4.2 Transport to the desired location

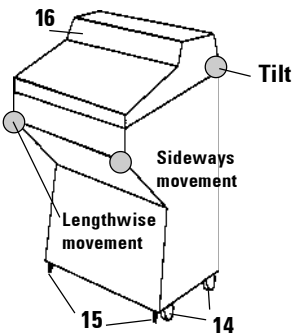

Fig. 4

- Move the instrument to the installation site on its wheels (**14**). Please note the areas which are reinforced for transporting and grip the cabinet only at these locations (Fig. 4).
- The adjustable feet (**15**) can support the weight of the instrument when tipping at a slight angle (max. 30 °).
- At the installation site unscrew the screws in the adjustable feet (**15**) using a fork wrench. This is necessary to ensure stability.
- Align the adjustable feet to level the instrument.



The instrument must be transported in an upright position only. When the instrument is tilted, the compressor oil is displaced. Do not grip the cabinet at the lid. Grip the cabinet only at the marked locations (○). The alignment of the adjustable feet is necessary to ensure an unobstructed drain of the quick freeze shelf defrosting water.

4.3 Standard delivery

It gives following variations:	- CM1850 with Retraction	0471 31150
	- CM1850 without Retraction (only US)	0471 31148
1 Handwheel, assy.		0416 18478
1 Heat extractor, stationary		0471 30792
1 Low temperature stabilizer for heat extractor, (Parking station).....		0471 30793
1 Optional clamping lever for object head		0112 28806
3 Specimen discs, 25mm diameter		0416 19275
1 Section waste tray		0471 30787
1 Storage shelf, right		0471 30789
1 Storage shelf, left		0471 30790
1 Brush, fine		0183 28642
1 Leica brush		0183 30751
1 Brush shelf		(0398 13088
1 Tool set:		
- 1 Allen key, size 2.5		0222 04137
- 1 Allen key, size 3		0222 04138
- 1 Allen key with spherical head, size 4		0222 32131
- 1 Allen key, size 6		0222 04141
- 1 Single-head wrench, size 16		0330 18595
1 Bottle of cryostat oil, type 407, 50 ml		0336 06098
1 Bottle of OCT-Compound, mounting medium for cryosectioning, 125 ml.....		0201 08926
1 Instruction manual Leica CM1850 - G/E/F/S		0708 37106

Compare the delivered components with the parts list and your order. Should you find any discrepancies, please contact your Leica sales office without delay.



A choice of different knife holders is available for the CM 1850. The knife holder is accompanied by its own separate instruction manual. Please contact your Leica sales office if the instruction manual is missing.

4. Unpacking and installation

4.4 Handwheel assembly

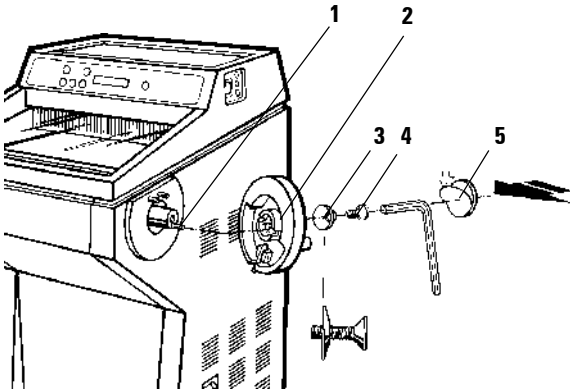

Fig. 5

- Insert the pin (1) of the handwheel shaft in to the hole (2) of the handwheel.
- Mount the spring washer (3) on the screw (4) as shown in Fig. 16.
- Tighten the screw (4) with an Allen key (5 mm).
- Attach the cover disc (5) (self-adhesive).

To dismount, proceed in reverse order.



The handwheel including the fixing components are packed in the cardboard box for the accessories. The handwheel can be dismounted for transporting (e.g. narrow doors).

5.1 Connection to mains power



During the start-up of the compressor the nominal voltage must not drop below the values specified in the 'Technical data'.

Please note that the compressor requires a start-up current between 45 and 50 A.

Therefore, the electric circuit at the installation site must be inspected by an electrical engineer to ensure that it meets the requirements for a smooth operation of the instrument.

A constant adequate power supply to the instrument must be ensured at all times.

Failure to comply with the above will cause severe damage to the instrument.

- The electric circuit at the place of installation must be protected separately.
- Do not connect any other consumers to this electric circuit.

5.2 Prior to operation

- Before connecting the instrument to the mains power, please check if the local mains voltage complies with the power rating indicated on the name plate of the instrument.
- Place the storage shelves in the cryochamber.
- Place the section waste tray and brush shelf in the cryochamber.
- Place the knife holder base on the microtome base plate.
- Insert the knife holder and clamp it on the base plate (For details, please refer to the separate instruction manual for your knife holder).
- Open the knife box with the knife and place it in the cryochamber for precooling.
- Place all tools needed for specimen preparation in the cryochamber.
- Close the sliding window.
- Connect the mains plug to the mains power outlet at the wall.

5. Setup

5.3 Leica CM1850 - Overview

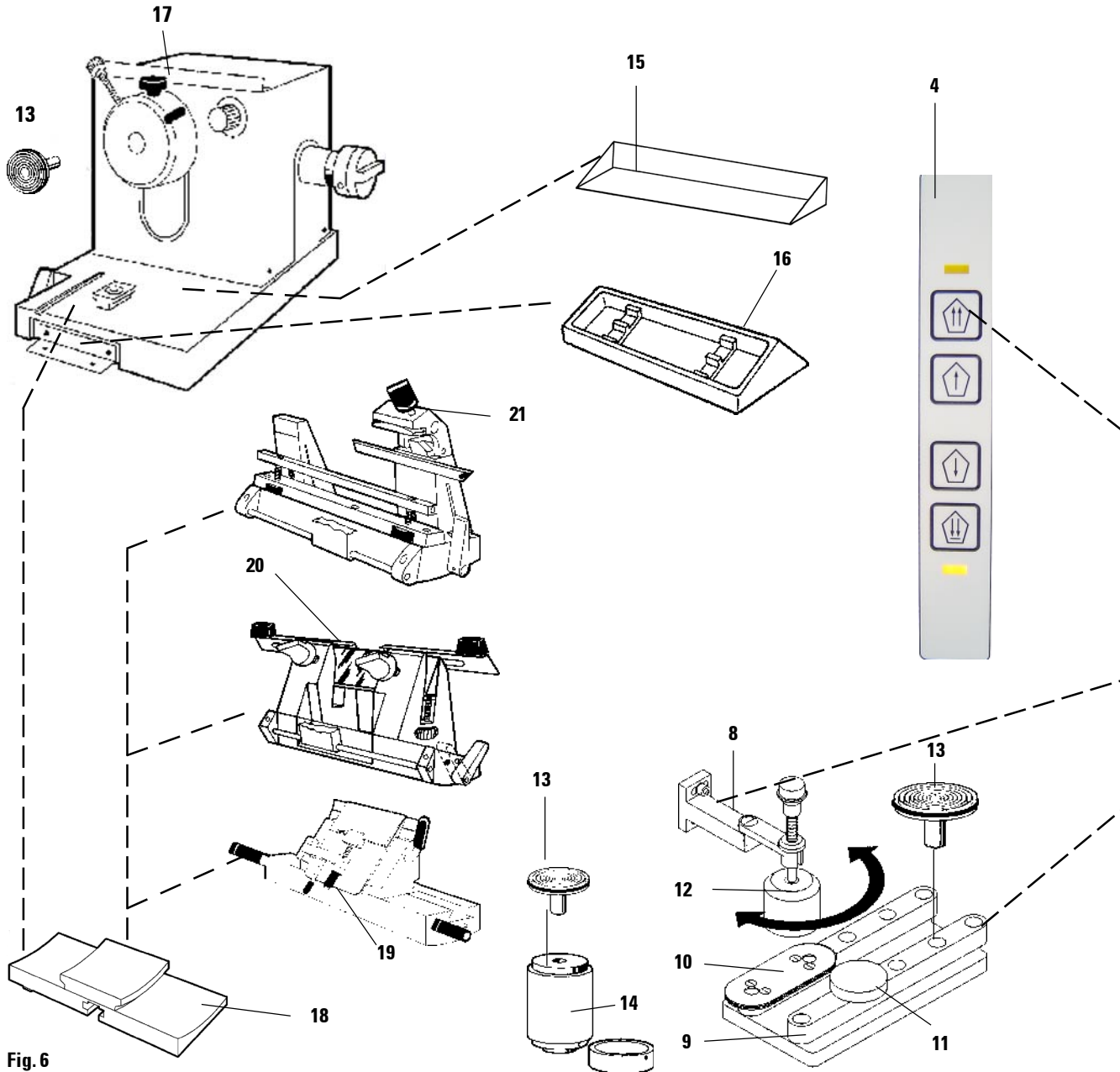
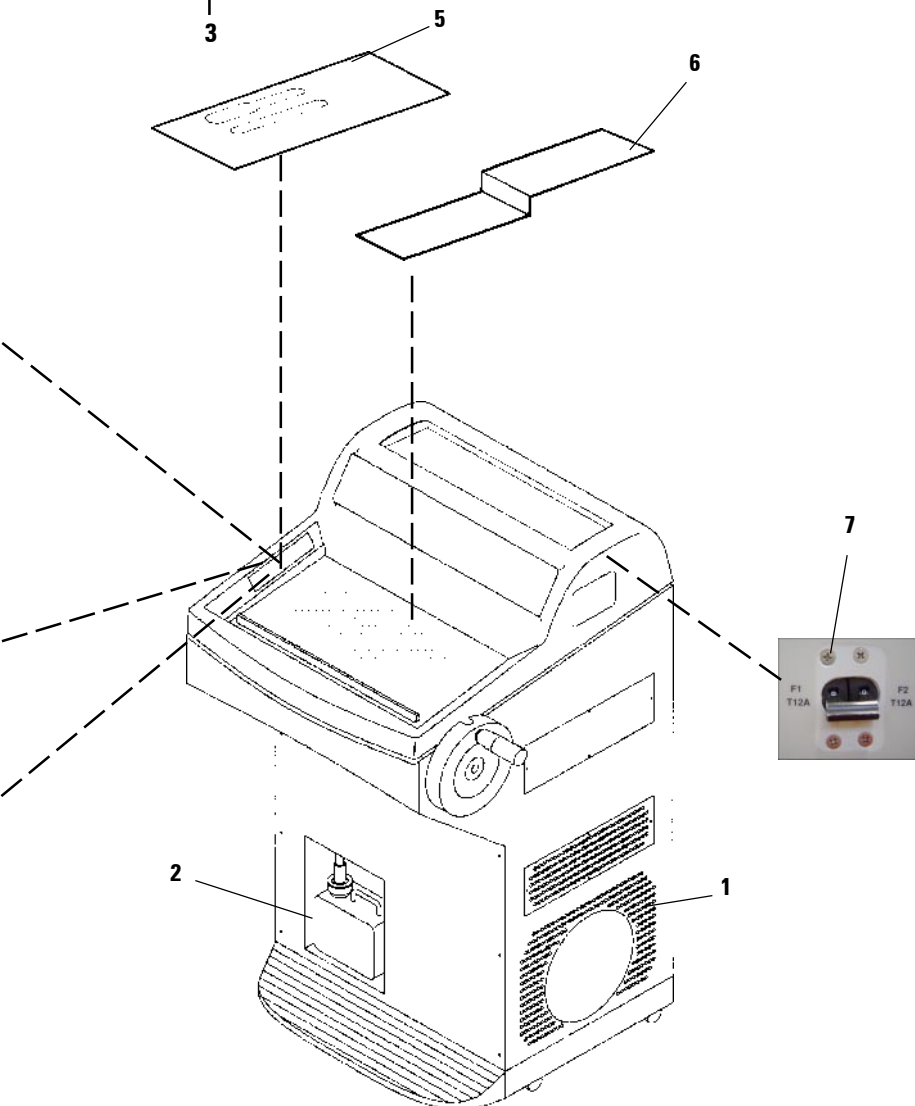

Fig. 6



- 1 Cryostat CM1850
- 2 Waste container
- 3 Control panel 1
- 4 Control panel 2
- 5 Storage shelf, left
- 6 Storage shelf, right
- 7 Automatic mains fuse
- 8 Support for stationary heat extractor (accessory)*
- 9 Quick freeze shelf
- 10 Peltier element (accessory)
- 11 Parking station (accessory)*
- 12 Stationary heat extractor (accessory)*
- 13 Specimen disc
- 14 Thermal bloc (accessory)
- 15 Section waste tray
- 16 Brush shelf
- 17 Orientable specimen head
- 18 Knife holder base (accessory)
- 19 Knife holder CE (accessory)
- 20 Knife holder CN (accessory)
- 21 Knife holder CS (accessory)

*) **included in the standard delivery range of models with Peltier element**

5. Setup

5.4 Mains switch and automatic mains fuse

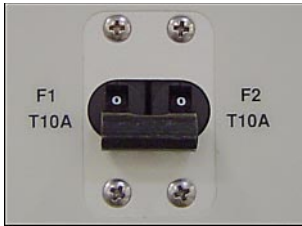

Fig. 7
Automatic mains fuse

The automatic mains fuse is used as mains switch.

To turn the automatic mains fuse on, the switch must be set in the upper position (pos. 1).

To turn the automatic mains fuse off, the switch must be set in the lower position (pos. 0).

5.5 Turning the instrument on



After transporting, wait at least 4 hours before turning the instrument on.

This waiting period is necessary to allow the compressor oil, which may have been displaced during transport, to return to its original position.

Failure to comply with this can cause severe damage to the instrument.

- Turn the instrument on with the automatic mains fuse.
- The instrument has been configured ex works as follows:

Time:	00:00
Defrost time:	10:00
Cryochamber cooling:	On (Indication of the temperature)
Peltier element (option):	Off Indication 'PE'
without Peltier element:	Indication 'LL'

- Set the desired values as described in the sections 6.2.1 to 6.2.3.



During normal operation pressure compensation prior to the compressor start-up might lead to a hissing sound.

6.1 Control panel 1

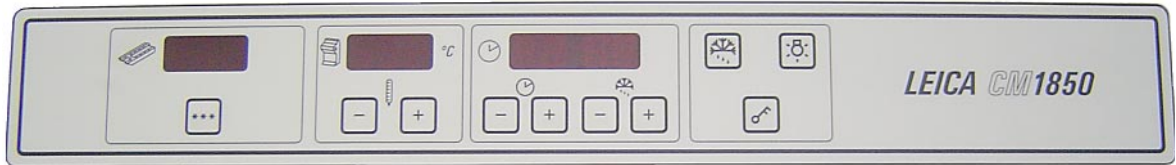

Fig. 8

Function keys



Lamp button
ON/OFF switch for cryochamber illumination.



Manual defrost button
To activate and deactivate manual defrosting.



Key button
To lock and unlock the control panel to protect the entered parameters from unintended modifications. To lock or unlock, hold down for approximately 5 seconds.

6.2 Programming the desired values

6.2.1 Setting the time



The actual time is set on the panel marked with the clock symbol using the \oplus and \ominus keys.

When pushing the \oplus or \ominus button for more than 1 second, the time value increases or decreases continuously (autorepeat function).



Fig. 9

6. Control panel operation

6.2.2 Setting the automatic defrost time (cryochamber)

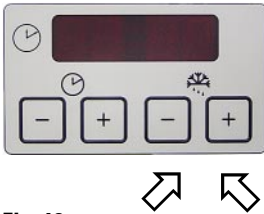

Fig. 10

The automatic defrost cycle takes place once within 24 hours.

Touch the \oplus or \ominus button for indication of the beginning of the defrost cycle which has actually been set. At the same time, the LEDs between the indication of hours and minutes are flashing.

To change the beginning of the defrost cycle in steps of 15 minutes, push the \oplus or \ominus button.

6.2.3 Selecting the cryochamber temperature

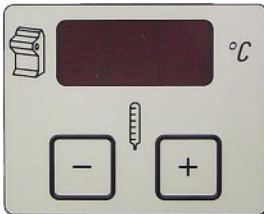

Fig. 11

The temperature of the cryochamber is set and indicated on the panel marked with the cryostat symbol.

The actual temperature is the standard indication.

For indication of the desired value, touch the \oplus or \ominus button.

Set the desired value with the \oplus and \ominus buttons. When pushing the \oplus or \ominus button for more than 1 second, the chamber temperature value increases or decreases continuously.

The actual value will be indicated 5 seconds after finishing the programming.

6.2.4 Activation of the Peltier element (option)



Fig. 12

The Peltier element is used for cooling the quick-freeze stations. Upon activation of the Peltier element, the compressor of the cooling system is started after 40 seconds to reinforce the thermal conductivity effect.

Display reading of instruments

without Peltier element: 'LL'

with Peltier element: 'PE'

The Peltier element is activated by pressing .

Once activated, the display indication changes to '10' (i.e. the Peltier element will operate for 10 minutes). The countdown of the remaining cooling time is permanently displayed.

The Peltier element turns off automatically after 10 minutes.

Once the remaining cooling time displayed is 4 minutes, the figure 4 is followed by a point ('4.'). At this stage the Peltier element may be deactivated by pressing  again.

Once deactivated, the display indication returns to 'PE'.



6.2.5 Manual defrosting of the quick freeze shelf





**The quick freeze shelf may become hot during defrosting!
Therefore, do not touch it!**



Fig. 13

The manual defrosting of the quick freeze shelf is activated by subsequently pressing the  button (audible signal turns on) and the  key (audible signal turns off). During the defrost cycle, the indication is flashing.

To turn off the manual defrosting cycle of the quick freeze shelf prior to the automatic deactivation, press again  and .



Quick freeze shelf and cryochamber defrosting can be run independently. However, it is not possible to defrost both systems simultaneously.

6. Control panel operation

6.2.6 Manual defrosting of the cryochamber

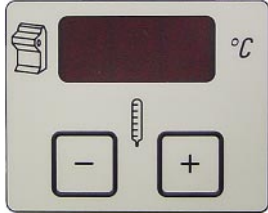







Fig. 14 

The manual defrosting of the cryochamber is activated by subsequently pressing the  button (audible signal turns on) and the  or  button on the panel for the cryochamber temperature (audible signal turns off). During the defrost cycle, the indication is flashing.

If you want to turn off the manual defrosting of the quick freeze shelf prior to the automatic deactivation, press again  and  or  on the panel for the cryochamber temperature.

6.3 Display lock



Fig. 15

The programmed values cannot be modified after having pushed the key button.

Push the key button once more for 5 seconds to unlock the display.

When the display is locked, the LEDs between the hour and minute indication on the time panel are turned off.

6.4 Control panel 2 - Electric coarse feed

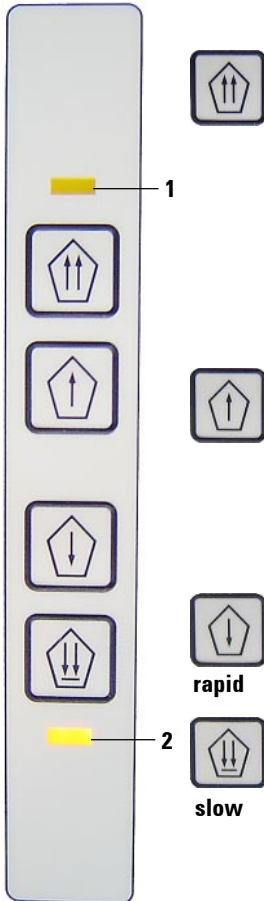

Move the specimen away from the knife

- Press to start a rapid return travel of the specimen to the rear limit. LED (1) flashes, while the specimen head is in motion.

On reaching the rear limit, the LED (1) starts illuminating.

- The return movement can be stopped by pressing one of the coarse feed buttons.
- Press to start a slow return movements of the specimen to the rear limit.

The specimen will slowly move to the rear limit, as long as the button is held down.

Move the specimen towards the knife

- Press to start a rapid or slow advance of the specimen towards the knife.

The advance movement operates as long as the button is pressed. This is a safety feature to protect both the specimen and knife from damage!

On reaching the front limit, the LED (2) of the button starts illuminating.

7. Daily use of the instrument

7.1 Specimen freezing

- Select the appropriate sectioning temperature (cryochamber temperature) for the sample material (please refer to **7.4 Temperature selection chart**).

7.1.1 Quick freeze shelf

The cryochamber has a quick freeze shelf (5, Fig. 17) for up to 10 specimen discs. The temperature of the quick freeze shelf is always lower than the cryochamber temperature.

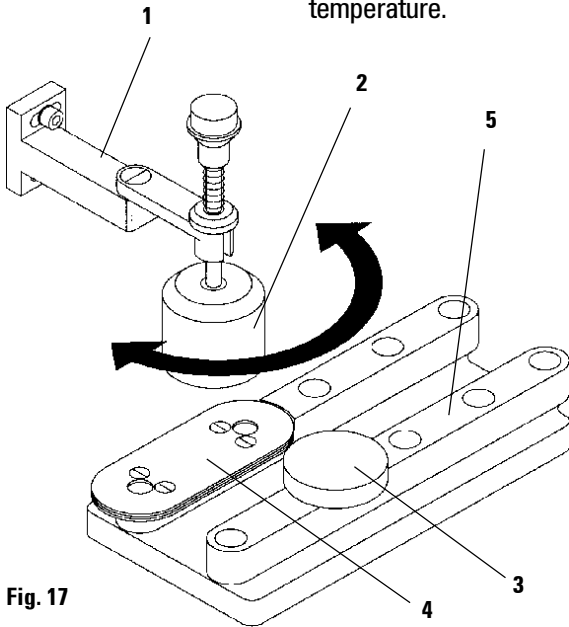

Fig. 17

- Cut the specimen to size.
- Activate the Peltier element (4) (option), if available - it may take up to 40 seconds until the maximum refrigeration output is available.
- Apply enough cryocompound to a specimen disc at room temperature.
- Place the specimen on the disc and orient.
- Place the specimen disc in one of the holes of the quick freeze shelf and freeze the specimen at a low temperature.
- Once the specimen is frozen, insert the specimen disc in the specimen head (Fig. 18) and start sectioning.

7.1.2 Stationary heat extractor (accessory)*

- Fix the support (1) of the heat extractor (2) by tightening the 2 screws to the threaded holes on the left sidewall of the cryochamber and insert the heat extractor.
- Lower the heat extractor cylinder on the specimen surface. After approximately 30 seconds contact, the specimen will be entirely frozen.
- Once the specimen is frozen, place the heat extractor on the parking station (3).

*) included in models with Peltier element

7.2 Specimen discs

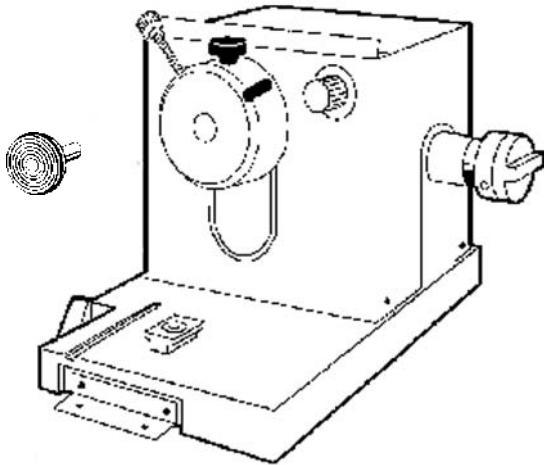

Fig. 18

7.2.1 Inserting the specimen discs in the specimen head

- Lock the handle of the handwheel in the upper position.
- If the knife holder and a knife are in place, cover the knife edge with the knife guard.
- Loosen the screw (1) on the specimen head.
- Insert the shaft of the specimen disc (3) in the location hole (2) of the specimen head.

Make sure that the shaft of the specimen disc is fully inserted. The entire rear surface of the prism must have a good contact with the specimen head.

- Retighten screw (1).

7.2.2 Specimen orientation

- To release, loosen screw (4).
- Orient the specimen surface with lever (5).
- Retighten screw (4).

7. Daily use of the instrument

7.3 Sectioning



All necessary adjustments on the knife holder and anti-roll guide are described in the separate instruction manual for your knife holder in detail.

7.3.1 Trimming the specimen



Take care when handling microtome knives and disposable blades. The cutting edge is extremely sharp and can cause severe injury!

- Insert the precooled knife/blade in the knife holder and clamp.
- Adjust the appropriate clearance angle on the knife holder. Adjustments between 4 ° and 6 ° (knife holder CN and CS) or between 1 ° and 2 ° (knife holder CE) are suitable for most applications.
- Align the knife holder/knife with the specimen.
- Remove the knife guard (knife holder CN, CS) or fold the glass anti-roll guide (knife holder CE) over to the left.
- Unlock the handwheel.
- Trim the specimen to shape approach the specimen towards the knife by means of the coarse feed buttons. Trim the specimen down to the required sectioning plane by turning the handwheel.
- Position the anti-roll guide on the knife and align with the cutting edge.
Readjust the anti-roll plate if necessary.

7.3.2 Section thickness setting

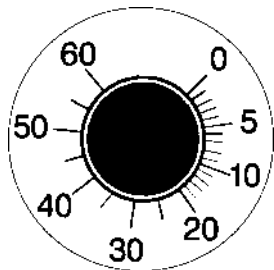

The section thickness is adjusted in a range of 1 to 60 μm by turning the knob (1): from 0 - 10 μm in 1 μm increments, from 10 - 20 μm in 2 μm increments, from 20 - 60 μm in 5 μm increments. The selected section thickness is indicated on the index mark on the microtome.

- Select the required section thickness with the control knob on the microtome.
Start sectioning at approximately 20 μm .
- Decrease the section thickness continually down to the appropriate value.
After changing from one section thickness to another, the first two or three sections should be rejected.
- When sectioning, turn the handwheel at a constant speed.

7.4 Temperature selection chart (in minus °C)

Tissue	-10°C – -15°C	-15°C – -25°C	-25°C – -35°C
Adrenal	*	*	
Bone marrow		*	
Brain		*	
Bladder		*	
Breast - fatty			*
Breast - little fat		*	
Cartilage	*	*	
Cervical		*	
Fatty			*
Heart and vascular		*	
Intestinal		*	
Kidney		*	
Laryngeal		*	
Lip		*	
Liver		*	
Lung			*
Lymphoid		*	
Muscular		*	
Nose		*	
Pancreatic		*	
Prostate		*	
Ovarian		*	
Rectal		*	
Skin with fat			*
Skin without fat		*	
Spleenal or bloody tissue		*	
Testicular	*	*	
Thyroid		*	
Tongue		*	
Uterus curettage	*		

The temperature values given above are based on long-term experience, however, these are only approximate values, as any tissue may require particular adjustments.

7. Daily use of the instrument

7.5 Defrosting

Defrosting the cryochamber actually means defrosting the evaporator to prevent excessive frost buildup. The evaporator is flushed with hot gas during defrosting. The cryochamber virtually is frostfree and does not need to be defrosted.

The condensation water that is produced during defrosting is collected in a container, which is located at the front of the cryostat cabinet.



To make sure that the condensation water stemming from the defrost cycles drains into the waste container and to avoid the risk of possible contaminations, ensure that the tap of the waste container (2, Fig. 41) is open when operating the instrument. Only shut the tap when draining the waste container!



The quick freeze shelf is cooled during the automatic cryochamber defrosting. However, the Peltier element is turned off. The maximum duration of a defrost cycle is 12 minutes. Defrosting is terminated automatically once the cryochamber has reached a temperature of -5°C . Cooling turns back on automatically.

7.5.1 Automatic defrosting of the cryochamber

An automatic defrost cycle takes place once in 24 hours.

The time of the automatic defrost cycle is programmed via the control panel 1 (see 6.2.1 and 6.2.2).

7.5.2 Manual defrosting of the cryochamber

In addition to the programmable automatic defrost cycle a manual defrost cycle can be activated (see also 6.2.6).



To avoid an unintended defrosting, the activation of a manual defrost cycle is confirmed by an audible signal. Cooling turns back on automatically.

7.5.3 Manual defrosting of the quick freeze shelf



**The quick freeze shelf may become hot during defrosting!
Therefore, do not touch it!**

If increased frost formation occurs on the quick freeze shelf, especially after spray disinfection, a manual defrost cycle should be started (see 6.2.5), which can be terminated when required.

7.6 Terminating work

7.6.1 Terminating daily work

- Lock the handwheel.
- Take the knife out of the knife holder and put it back into the knife box in the cryochamber.
- Remove frozen section waste with a cold brush.
- Empty the section waste tray.
- Clean the storage shelves and brush shelf.



**Only common detergents and disinfectants that contain 95 - 98% alcohol should be used for cleaning.
All components removed from the cold environment will collect condensation. Therefore, dry them thoroughly before placing them back into the cryochamber.**

- Remove all specimens from the cryostat.
- Close the sliding window.
- Turn out the cryochamber illumination.
- Lock control panel 1 (**Fig. 8**) with the KEY button.
- **Do not** turn the instrument off with the automatic mains fuse as there would be no cooling.

8. Troubleshooting

7.6.2 Shutdown for a longer period



If you do not intend to use the instrument for several weeks you may turn it off.

Please note, however, that it may take up to several hours to cool the cryochamber down to very low temperatures after turning the instrument on again.

After turning off, the instrument should be cleaned and disinfected thoroughly (see chapter 9 'Cleaning, disinfection and maintenance').

- Turn the instrument off with the automatic mains fuse.
- Open the sliding window to allow the cryochamber to dry.
- Remove all the specimens from the cryostat.
- Lock the handwheel.
- Take the knife/blade out of the knife holder. Put the knife back into the knife box or push the blade into the receptacle for used blades provided at the bottom of the dispenser.
- Remove all section waste with a cold brush.
- Empty the section waste tray and remove it for cleaning and disinfection.
- Remove the storage shelves and the brush shelf for cleaning and disinfection.

Turning off the instrument with the automatic mains fuse will not affect the programmed parameters.

Before turning the instrument on again, the cryochamber microtome and all accessory components must be absolutely dry.

8.1 Error messages in the display



Fig. 20

Error messages are displayed on the clock panel as follows: E0: XX. The following error messages might occur during operation:

Error	Description	Remedy
20	Calibrating error; possibly defective controller board.	Turn the instrument on again. If the error is displayed again: Call service.
21	Clock battery on the controller board empty.	Call service.
22	Microtome wet.	Dry microtome.
23	Cryochamber temperature out of range of indication. (from -35 °C to +55 °C)	Remove cause.
24	Short circuit at the temperature sensor of the chamber cooling system.	Call service.
25	Breaking of the temperature sensor of the chamber cooling system.	Call service.
26	Short circuit at the temperature sensor of the evaporator.	Call service.
27	Breaking of the temperature sensor of the evaporator.	Call service.

8.2 Temperature control button

On the back of the cryostat cabinet there is a temperature control button (1). If the temperature of the cryochamber exceeds 60 °C the switch is automatically activated and turns the instrument off.

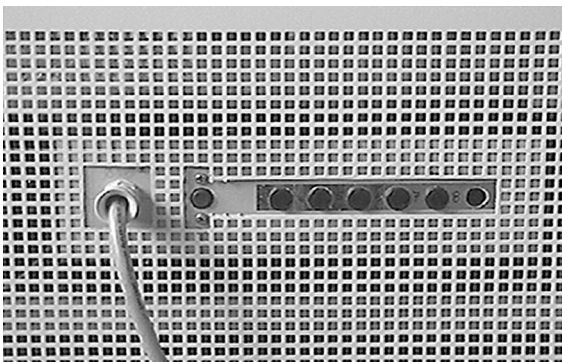

Fig. 21

Possible causes and remedies:

- Temperature of the direct surroundings is constantly higher than 40 °C.
--> Drop the temperature of the direct surroundings.
- When setting up the instrument the minimum distance of 10 cm to walls and furniture was not kept.
--> Keep the minimum distance.
- The ventilation slits of the liquefier are dirty.
--> Clean the ventilation slits (see 9.3.1).

After eliminating the possible source of error, push the temperature control button (1) to turn the instrument back on. If the instrument fails to turn on, make a service call.

8. Troubleshooting

8.3 Possible causes and remedies

Problem	Cause	Remedy
Frost on chamber walls and microtome	<ul style="list-style-type: none">- Cryostat is exposed to air currents (open windows and doors, air conditioning).- Sliding window was open and exposed to air currents too long.- Frost built up by breathing into the cryochamber.	<ul style="list-style-type: none">- Change place of installation for the cryostat.
Ice formation on the bottom of the cryochamber	<ul style="list-style-type: none">- Condensation water drain obstructed.- Drain of the quick freeze shelf defrosting water obstructed.	<ul style="list-style-type: none">- Open the tap of the drain tube (2, Fig. 31), switch off the instrument and let it thaw and dry.- Align the instrument with a spirit level.
Sections smear	<ul style="list-style-type: none">- Specimen not cold enough.- Knife/blade and/or anti-roll plate not yet cold enough and thus warm the sections.	<ul style="list-style-type: none">- Select lower temperature.- Wait until knife/blade and/or anti-roll plate have reached chamber temperature.
Sections splinter	<ul style="list-style-type: none">- Specimen too cold	<ul style="list-style-type: none">- Select higher temperature.
Sections not properly flattened	<ul style="list-style-type: none">- Static electricity/air currents.- Specimen not cold enough.- Large area specimen.- Anti-roll plate poorly positioned.- Anti-roll plate poorly aligned with knife edge.- Incorrect clearance angle.- Knife/blade blunt or damaged.	<ul style="list-style-type: none">- Remove cause.- Select lower temperature.- Trim the specimen parallel, increase section thickness.- Reposition anti-roll plate.- Align correctly.- Set correct angle.- Use different part of the cutting edge or replace.

Problem	Cause	Remedy
Sections not properly flattened despite correct temperature and correctly aligned anti-roll plate	<ul style="list-style-type: none"> - Knife/blade and/or anti-roll plate dirty. - Edge of anti-roll plate damaged. - Blunt knife/blade. 	<ul style="list-style-type: none"> - Clean with dry cloth or brush. - Replace plate. - Use different part of the cutting edge or replace.
Sections curl on the anti-roll plate	<ul style="list-style-type: none"> - Anti-roll plate does not protrude far enough beyond the cutting edge. 	<ul style="list-style-type: none"> - Readjust correctly.
Scraping noise during sectioning and specimen return movement	<ul style="list-style-type: none"> - Anti-roll plate protrudes too far beyond the cutting edge and is scraping against the specimen. 	<ul style="list-style-type: none"> - Readjust correctly.
Ridged sections	<ul style="list-style-type: none"> - Knife/blade damaged. - Edge of anti-roll plate damaged. 	<ul style="list-style-type: none"> - Use different part of the cutting edge or replace. - Replace the plate.
Chatter during sectioning	<ul style="list-style-type: none"> - Specimen insufficiently frozen onto the specimen disc. - Specimen disc not clamped tightly. - Specimen holder ball joint not clamped. - Knife/blade not clamped tightly enough. - Specimen has been sectioned too thickly and has detached from the disc. - Very hard, inhomogeneous specimen. - Blunt knife/blade. 	<ul style="list-style-type: none"> - Refreeze specimen onto the disc. - Check disc clamping. - Check ball joint clamping. - Check knife/blade clamping. - Refreeze specimen onto the disc. - Increase section thickness; reduce specimen surface area if necessary. - Use different part of the cutting edge or replace the knife/blade.

8. Troubleshooting

Problem	Cause	Remedy
	<ul style="list-style-type: none">- Knife profile inappropriate for the specimen to be cut.- Incorrect clearance angle.	<ul style="list-style-type: none">- Use knife with different profile.- Set correct angle.
Condensation on anti-roll plate and knife during cleaning	<ul style="list-style-type: none">- Brush, forceps and/or cloth are too warm.	<ul style="list-style-type: none">- Store all tools on shelf in the chamber.
Anti-roll plate damage after adjustment	<ul style="list-style-type: none">- Plate too high above the cutting edge. The adjustment was carried out in the direction of the cutting edge.	<ul style="list-style-type: none">- Raise plate when aligning.- Be more careful next time.
Thick-thin sections	<ul style="list-style-type: none">- Temperature incorrect for the tissue cut.- Knife profile inappropriate for the specimen cut.- Ice buildup in the knife back.- Handwheel speed not uniform.- Knife/blade not clamped tightly enough.- Specimen holder not clamped tightly.- Cryocompound applied to cold specimen disc; specimen detached from the disc after freezing.- Blunt cutting edge.- Incorrect clearance angle.- Microtome not properly dried before reinstallation.- Dried specimen.	<ul style="list-style-type: none">- Select correct temperature.- Wait until the correct temperature is reached.- Use knife with different profile (c or d).- Remove ice.- Adapt speed.- Check knife/blade clamping.- Check clamping.- Apply cryocompound on warm disc; mount specimen and freeze.- Use different part of the cutting edge or replace the knife/blade.- Set correct angle.- Dry microtome thoroughly.- Prepare new specimen.
Tissue sticks or crumbles on the anti-roll plate	<ul style="list-style-type: none">- Anti-roll plate is too warm or incorrectly positioned.- Static electricity.	<ul style="list-style-type: none">- Cool down anti-roll plate or reposition plate.- Remove static electricity.

8. Troubleshooting

Problem	Cause	Remedy
	<ul style="list-style-type: none">Fat on the corner or edge of the anti-roll plate.- Rusty knife/blade.	<ul style="list-style-type: none">- Remove fat with alcohol.- Remove rust.
Flattened sections curl up when anti-roll plate is picked up	<ul style="list-style-type: none">- Static electricity or air currents.- Anti-roll plate too warm.	<ul style="list-style-type: none">- Remove static electricity.- Cool down the anti-roll plate.
Sections tear	<ul style="list-style-type: none">- Temperature too low for the tissue cut.- Blunt part, dirt, dust, frost or rust on the knife/blade.- Leading edge of anti-roll plate damaged.- Hard particles in the tissue.- Knife back dirty.	<ul style="list-style-type: none">- Increase temperature and wait.- Remove cause.- Replace the plate.- - -- Clean.
Inconsistent or insufficient specimen feed	<ul style="list-style-type: none">- Microtome was not entirely dry when switching on refrigeration; consequently ice built up in the micrometer feed system.- Defective microtome.	<ul style="list-style-type: none">- Remove the microtome and dry it thoroughly before reinstallation.- Call technical service.
Specimen disc cannot be removed	<ul style="list-style-type: none">- Moisture on the underside caused the disc to freeze to the freezing shelf or specimen head.	<ul style="list-style-type: none">- Apply concentrated alcohol to the contact point or heat the specimen head.
Cryostat inoperational	<ul style="list-style-type: none">- Mains plug not properly connected.- Defective fuses.- Temperature control switch activated.	<ul style="list-style-type: none">- Check the mains plug is properly connected.- Replace the fuses.- Check site conditions as described in section 5.2, and reset the temperature control switch.

8. Troubleshooting

Problem	Cause	Remedy
No or insufficient refrigeration	<ul style="list-style-type: none">- Compressor defective.- Leak in the cooling system.- Inappropriate site conditions. - Ventilation slits of the liquefier dirty.	<ul style="list-style-type: none">- Call technical service.- Call technical service.- Check site conditions as described in section 5.2.- Clean the ventilation slits as described in section 10.3.1.
Scraping noise at the microtome	<ul style="list-style-type: none">- Friction between the slot cover and the microtome housing.	<ul style="list-style-type: none">- Apply cryostat oil to the slot cover and distribute by turning the handwheel or with a cloth.

9.1 Cleaning

- Remove frozen section waste from the cryostat with a cold brush every day.
- Remove the section waste tray for emptying.
- Remove the storage shelves and the brush shelf for cleaning.
- Remove the sliding window by slightly lifting and pulling it to the front when closed (see 9.3.6 'Replacement of the lamp').



Do not use organic solvents or any other aggressive substances for cleaning and disinfecting! Only use the cleaning agents specified in this instruction manual such as Leica Cryofect (alcohol or common disinfectants based on alcohol)!

- Drain the cleaning liquid through the hose after the prescribed reagent time is over and collect it in the waste container (1).

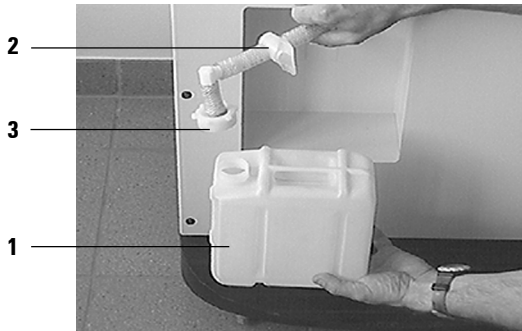

- Dispose of the waste liquid according to the waste disposal regulations.
- To remove the waste container (1), shut off the tap (2) and unscrew the lid (3).

Fig. 22



Condensation water produced during defrosting collects in the waste container. Therefore, check the liquid level regularly and empty the container if necessary.

9. Cleaning, disinfection, maintenance

9.2 Spray disinfection with Leica Cryofect

For easy-to-use spray disinfection we recommend Leica Cryofect. The cryostat has to be disinfected after each daily use.



**Comply with the instructions for use!
The glass anti-roll plate can remain in place during disinfection.**

1. Select a cryochamber temperature value down to -20 °C.
2. Remove the knife or blade from the knife holder.
3. Remove all samples, microscope slides and tools from the cryochamber.
4. Remove debris from the cryochamber.

Allow the cryochamber to reach the previously selected temperature. Once the selected temperature is reached, either

- 5a. spray the disinfectant evenly on the contaminated surfaces- the surfaces should be covered with an even layer - or
- 5b. soak a cloth with disinfectant and apply it on the contaminated surfaces.
6. Allow a reaction time of no less than 15 minutes.
7. Wipe it off with a tissue.
8. Dispose of tissue in compliance with the ruling waste disposal regulations of your institution.
9. Set the cryochamber temperature to the originally selected value.



If increased frost buildup occurs, start a manual defrost cycle.

9.3 Maintenance

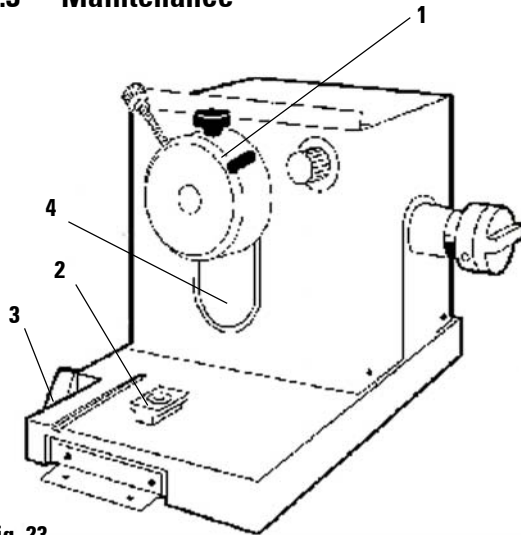

Fig. 23

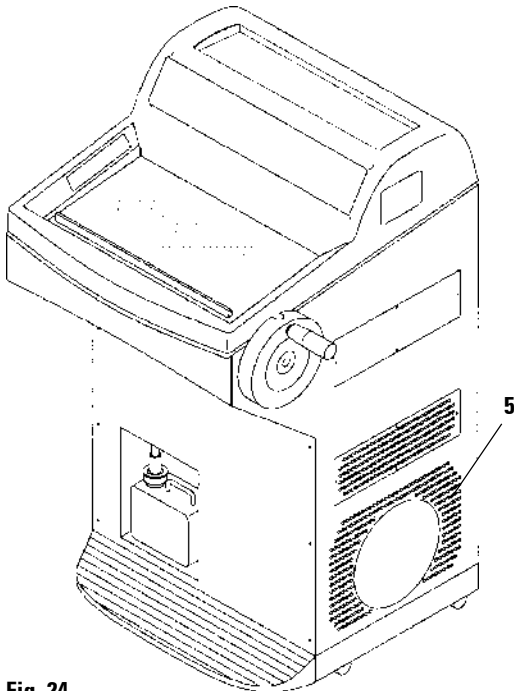

Fig. 24

9.3.1 General maintenance

The microtome is virtually maintenance-free. To ensure a smooth operation of the instrument over several years we recommend the following:

- Have the instrument inspected by a qualified service engineer authorized by us **once a year**.
- Enter into a service contract at the end of the warranty period.
For further information, please contact your local Leica service center.
- Clean the instrument **every day**.

Once a week:

- Apply a drop of oil to the plastic coupling (5, Fig. 26).
- Lubricate the specimen cylinder (1):
Push the appropriate coarse feed button to move the specimen cylinder out to the front stop position, apply a drop of cryostat oil and move the specimen cylinder back to the home position by pressing the appropriate coarse feed button.

Occasionally, or when required:

- Lubricate the clamping piece (T-piece) (2) on the microtome base plate and the clamping lever (3).
- Lubricate the slot cover (4).
To do so, turn the handwheel to place the specimen head to the uppermost position and apply some drops of cryostat oil on to the slot cover; after that place the specimen head to

9. Cleaning, disinfection, maintenance

the lowest position and apply some drops of cryostat oil on to the slot cover; distribute the applied oil by turning the handwheel or with a soft tissue.

- Clean the ventilation slits (5) of the liquefier on the right side of the instrument with a brush, broom or vacuum cleaner from dust and dirt in the direction of the fins.
- Do not carry out any repairs on your own as this will invalidate the warranty. Repairs may only be carried out by qualified service engineers authorized by Leica.



The microtome can be removed for thorough cleaning and disinfecting, or for extensive drying after a long power failure!

9.3.2 Removal of the microtome



Turn the instrument off and disconnect the mains plug before removing the microtome.

Prior to removing the microtome, place the specimen head to the lowest position by placing the handle of the handwheel in the lowest position.

When removing the microtome, the specimen head will rapidly fall down and might injure the operator's hands.

Wear appropriate protective gloves to take the cold microtome out of the cryochamber!

Extended skin contact with cold parts of the instrument may cause frost bite!

- Slightly lift the sliding window when closed holding it at the grip provided and pull it out to the front (**Fig. 30**) - see '**9.3.6 Replacement of the lamp**'.
- Remove the accessories in the following order: brush shelf, knife holder, section waste tray, specimen discs, stationary heat extractor, left storage shelf, right storage shelf.

9. Cleaning, disinfection, maintenance

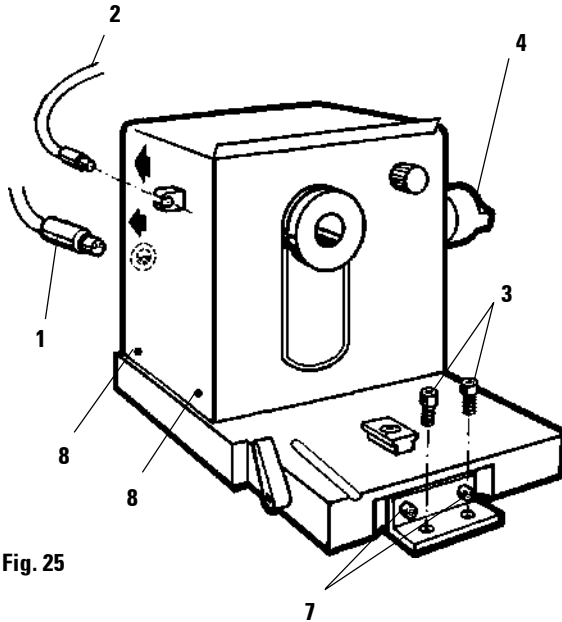

Fig. 25

- Loosen the screws (3) with an Allen key (4 mm). **Do not loosen the screws (7) for removing the microtome.**
- Disconnect the coarse feed motor plug (1) by pulling the metal head.
- Disconnect the temperature sensor (2) from the microtome.

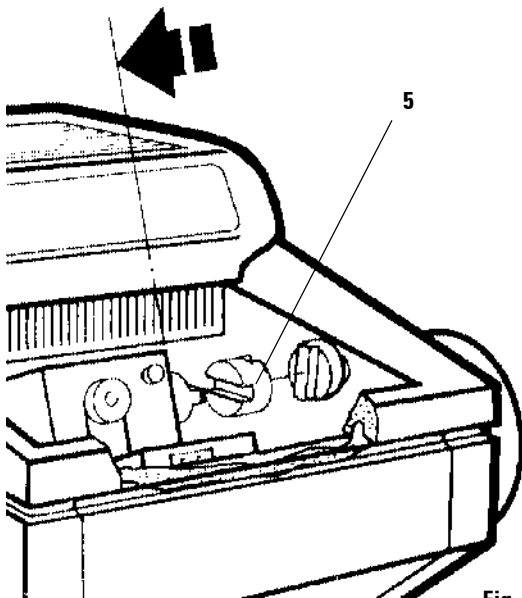

Fig. 26

- Slightly lift the microtome and pull it to the left to disengage the plastic coupling (5) connecting the axes.
- Take the microtome out of the cryochamber.

9. Cleaning, disinfection, maintenance

9.3.3 Removal of the microtome cover

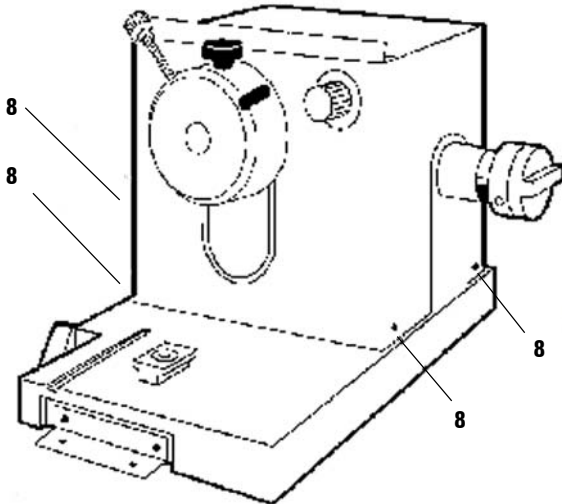

Fig. 27



The microtome cover may be removed to expedite thorough drying of the microtome in an oven. **Note:**

Place the microtome in an oven at 40 °C to 50 °C for several hours.

After repeatedly drying the microtome in this manner, it may become necessary to relubricate the cross roller bearings!

For further information, please contact your sales company!

- Loosen the two screws (8) on both sides of the cover.
- To remove, pull the cover upwards. The front plate of the microtome with the specimen head remains in place.



Do not use external heaters for drying the cryochamber!

This can cause damage to the cooling system!

9.3.4 Reinstallation of the microtome

- Place the microtome slightly left from the original position into the cryochamber. Make sure that the specimen head is in the lowest position.
- Lubricate the surface of the plastic coupling (5) with a drop of cryostat oil.
- Mount the plastic coupling (5) on the shaft (4).
- Use your right hand to bring the handwheel handle in the lowest position and keep the handle in place. The specimen head remains in the lower position.



Ensure that the microtome is completely dry before reinstallation.
Humidity inside will condense and freeze and thus cause malfunctions or damage to the feed system of the microtome.

- Use your right hand to bring the handwheel handle in the lowest position and keep the handle in place. The specimen head remains in the lower position.
- Push the microtome to the right with your left hand, and, if necessary, turn the handwheel back and forth to ensure proper alignment of the parts until the plastic coupling (5) engages to the shaft (6).
- Tighten the screws (3).
- Reconnect the coarse feed motor plug (1) and the temperature sensor (2).
- Replace the storage shelves, heat extractor, brush shelf and knife holder in the cryochamber.
- Replace the sliding window.

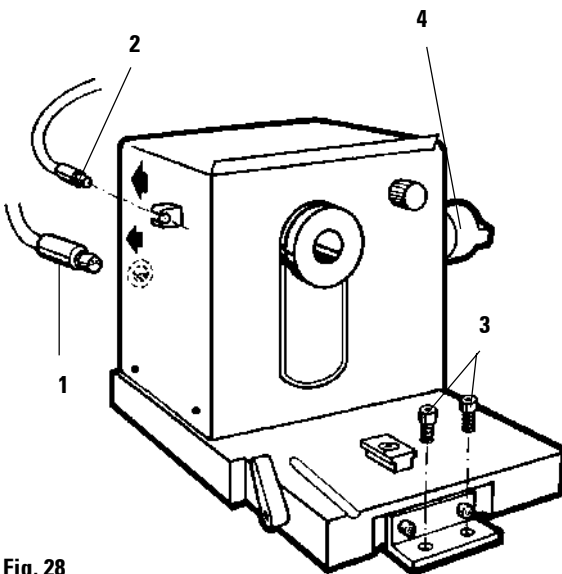

Fig. 28

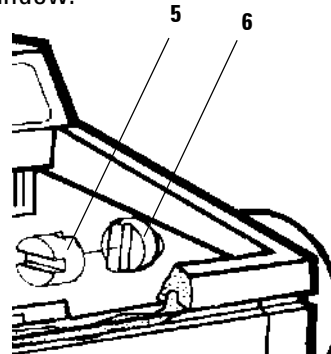

Fig. 29



Ensure that all components removed from the cold environment are completely dry before placing them back into the cryochamber.

9. Cleaning, disinfection, maintenance

9.3.5 Replacement of the fuses



Turn the instrument off with the automatic mains fuse and pull the mains plug, before replacing the fuses!
Only use fuses of the same specification! For the required values, please refer Chapter 3 'Technical Data'. The use of fuses other than specified by the manufacturer may cause severe damage to the instrument!

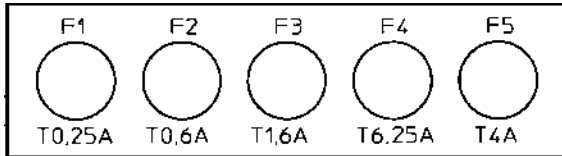

Fig. 29

Fuse	Protection	Type
F1	Display	T 0.25 A
F2	Coarse feed	T 0.6 A
F3	Processor board supply	T 1.6 A
F4	Peltier element	T 6.25 A
F5	Heaters	T 4 A

On the back of the instrument there is a fuse box with 5 fuses:

- Unscrew the fuse cap with a screwdriver.
- Remove both fuse cap and fuse.
- Put the new fuse in the cap and screw the fuse cap back on.

9.3.6 Replacement of the lamp



Turn the instrument off with the automatic mains fuse and pull the mains plug, before replacing the lamp!
If the lamp is broken, it must be replaced by the technical service, as the replacement involves a high risk of injury.

9. Cleaning, disinfection, maintenance

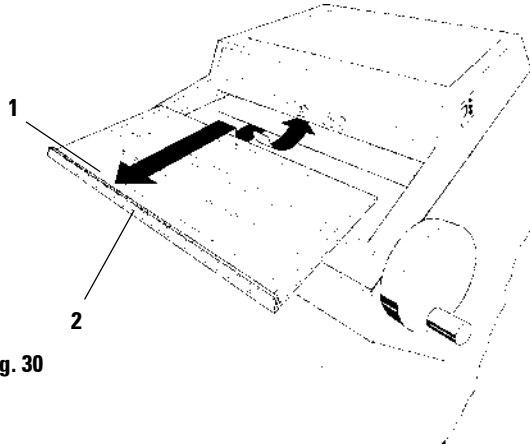

Fig. 30

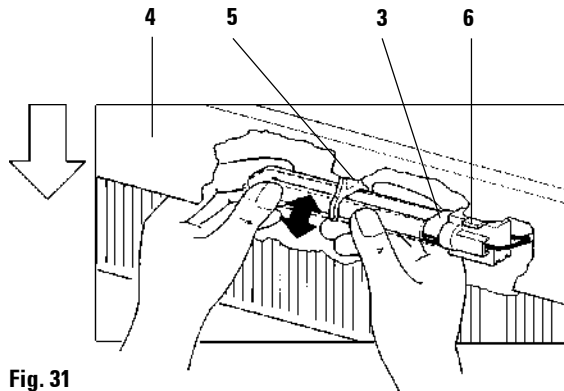

Fig. 31

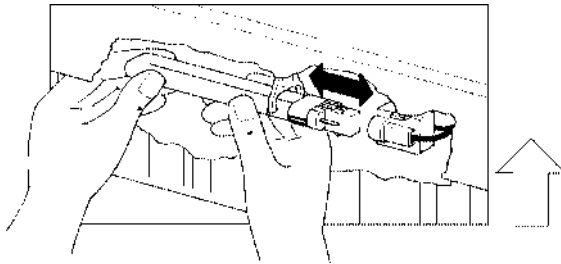

Fig. 32

- Turn the instrument off with the automatic mains fuse.
- Pull the mains plug.
- Slightly lift the sliding window (1) holding it by the grip (2) and pull it out to the front.
- For the technical specification of the lamp, please refer to Chapter 4. 'Technical data'.

Removal of the lamp

The lamp (3) is mounted behind a glare shield (4) and therefore not visible.

- Touch the lamp for better orientation.
- **Lightly** tilt the fluorescent tube down to the left and pull it out of the clip (5).
- Hold the lamp with both hands and pull it **to the left** out of the holder (6).

Installation of the new lamp

- Hold the lamp in the correct mounting position as shown (Fig. 32) and push it to the right until it engages in the holder.
- Lightly push the fluorescent tube upward to engage in the clip.
- Replace the sliding window.
- Reconnect the instrument to the mains power and turn it on.

10. Ordering information, optional accessories

10.1 Ordering information

Knife holders

Knife holder CN for standard knives for reusable knives or the magnetic blade rail for disposable blades, with anti-roll guide, adjustable knife guard and knife support bars	0419 18649
Knife support bar for knife holder CN, for slim knives	0419 19426
Knife support bar for knife holder CN, for broad knives	0419 19427
Knife holder CE for low profile disposable blades with glass anti-roll guide	0419 30383
Knife holder CE for high profile disposable blades with glass anti-roll guide	0419 30390
Knife holder CS for reusable knives and Cryolap disposable blades, with one knife support (to be positioned on the left or right), anti-roll guide, knife guard	0419 19787
Auxiliary clamping device for knife holder CS	0419 20971
Knife support bar for knife holder CS	0419 25681
Knife holder base for the knife holders CN, CE and CS	0419 26140
Knife rest with section collecting tray for knife holder CS	0419 18996

Specimen discs

Specimen disc, 20 mm \varnothing	0370 08636
Specimen disc, 25 mm \varnothing	0416 19275
Specimen disc, 30 mm \varnothing	0370 08587
Specimen disc, 40 mm \varnothing	0370 08637
Specimen disc, 55 mm \varnothing	0419 26491

Accessories

Stationary heat extractor with support *	0471 30792
Parking station *	0471 30793
Mobile heat extractor *	0443 26836
Thermal bloc to remove frozen specimens from the cold specimen disc	0398 18542
Glass anti-roll guide, complete assembly, for knife holder CE	0419 30402
Glass anti-roll-guide upgrade kit, for retrofitting knife holders CN, CS (for C-profile knives)	0419 30403

Consumables

OCT cryocompound, bottle of 125 ml	0201 08926
Cryostat oil No. 407, bottle of 100 ml	0336 06099
Leica Cryofect Spray disinfectant	0387 30795

* included in standard delivery on models with Peltier element

10.2 Optional accessories

10.2.1 Mobile heat extractor

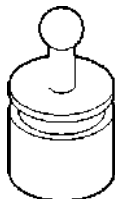

Fig. 33

Specimen freezing with the freezing shelf can be accelerated by the additional use of a heat extractor.

- Store the heat extractor in the cryochamber.
- Place it on the specimen surface to accelerate freezing.
- Remove it once the specimen is entirely frozen. It is recommended to precool the heat extractor in liquid nitrogen or other refrigerant.



It is recommended to precool the heat extractor in liquid nitrogen or other refrigerant.

10.2.2 Thermal block

The thermal block (8) facilitates the removal of the frozen specimen from the specimen disc.



Keep the thermal block outside the cryochamber at room temperature. Place it in the cryochamber only for specimen removal.

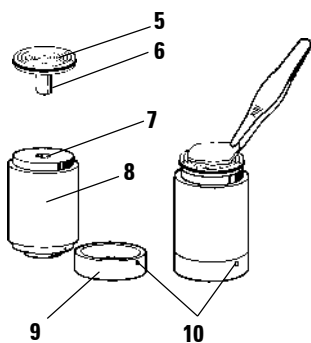

Fig. 34

- Place the cap (9) on the required side, so that the appropriate location hole for the specimen disc is visible.
- Insert the shaft (6) of the specimen disc (5) in the appropriate location hole (7) at the top or bottom of the thermal block.
- After about 20 seconds, the frozen specimen can be removed from the specimen disc with forceps.
- If the cap is too loose, readjust it with the small screw (10). Do not over-tighten the screw.
- Once the specimen is removed, take the thermal block out of the cold cryochamber.

11. Warranty and service

Warranty

Leica Microsystems Nussloch GmbH guarantees that the contractual product delivered has been subjected to a comprehensive quality control procedure based on the Leica in-house testing standards, and that the product is faultless and complies with all technical specifications and/or agreed characteristics warranted.

The scope of the warranty is based on the content of the concluded agreement. The warranty terms of your Leica sales organization or the organization from which you have purchased the contractual product shall apply exclusively.

Technical service information

If you require technical service or replacement parts, please contact your Leica sales representative or dealer who sold the product.

Please provide the following information:

- Model name and serial number of the instrument.
- Location of the instrument and name of the person to contact.
- Reason for the service call.
- Date of delivery.

Decommissioning and disposal

The instrument or parts of the instrument must be disposed of in compliance with the local laws.